



**TEREX** | AMERICAN

**HC 165** | Hydraulic Crawler Crane 165 t Lifting Capacity



# HC 165

**HYDRAULIC CRAWLER CRANE**

HC 165  
**HIGHLIGHTS**

- ▶ 165 tons maximum lifting capacity
- ▶ 270 ft maximum length of main boom
- ▶ 80 ft maximum jib
- ▶ 320 ft maximum boom and jib length
- ▶ 319 horsepower Cummins engine
- ▶ Optional boom tips
- ▶ Optional 3<sup>rd</sup> drum configurations
- ▶ Increased capacity at working radii with optional counterweight
- ▶ Proven American 77" boom and 16HL jib
- ▶ Fully self-erectable
- ▶ Power up / power down and freefall on main, auxiliary and optional third drum
- ▶ Quiet operator's cab with spacious width
- ▶ 360° viewing range
- ▶ Two speed travel
- ▶ Powerful, high speed hoist drums
  
- ▶ **The ultimate crane!**

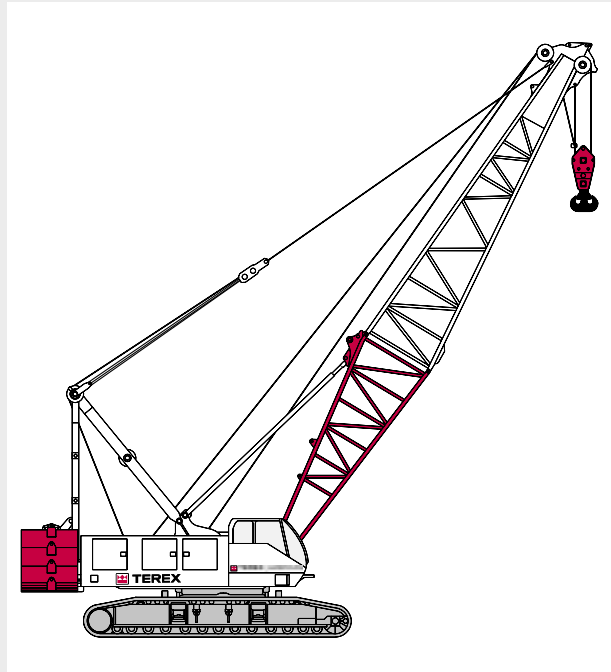

**CONTENTS**

Page:

**Specifications**

Dimensions .....	4
------------------	---

**Main boom**

Range diagram, 77SI hammerhead tip boom .....	6
With 77SI hammerhead tip boom and 102,000 pound upper counterweight .....	7
With 77SI hammerhead tip boom and optional 108,400 pound of upper and 8,000 pound of carbody counterweight .....	10
Range diagram, 77SI offset tip boom .....	14
With 77SI offset tip boom and 102,000 pound upper counterweight .....	15
With 77SI offset tip boom and optional 108,400 pound of upper and 8,000 pound of carbody counterweight .....	18

**Jib**

Range diagram, 77SI hammerhead tip boom, #16HL Jib .....	22
With 77SI hammerhead tip boom and 102,000 pound upper counterweight, #16HL Jib .....	23
With 77SI hammerhead tip boom and optional 108,400 pound of upper and 8,000 pound of carbody counterweight, #16HL Jib .....	30
Range diagram, 77SI offset tip boom, #16HL Jib .....	38
With 77SI offset tip boom and 102,000 pound upper counterweight, #16HL Jib .....	39
With 77SI offset tip boom and optional 108,400 pound of upper and 8,000 pound of carbody counterweight, #16HL Jib .....	48

**Technical description**

Hydraulic Crawler Crane .....	58
Hoist Drum Performance .....	59

**Transport example for HC 165**

.....	60
-------	----

1

2

3

4

5

**DIMENSIONS**

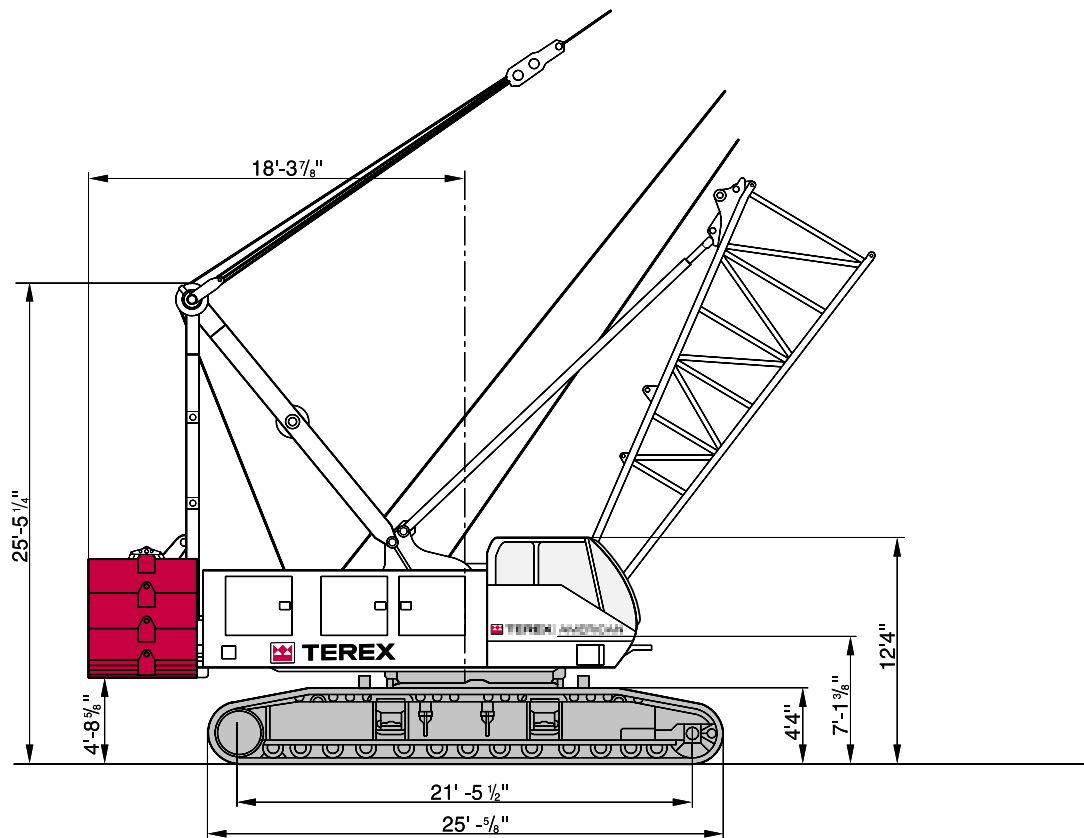

**DIMENSIONS**

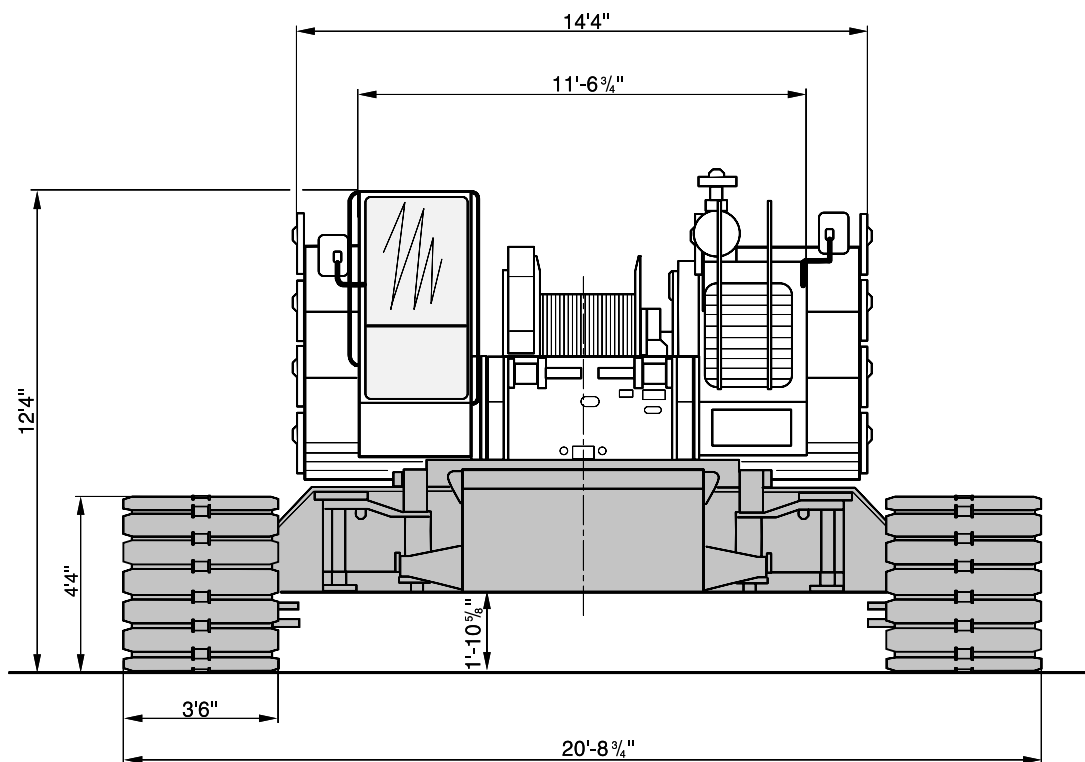

**RANGE DIAGRAM, 77SI HAMMERHEAD TIP BOOM**

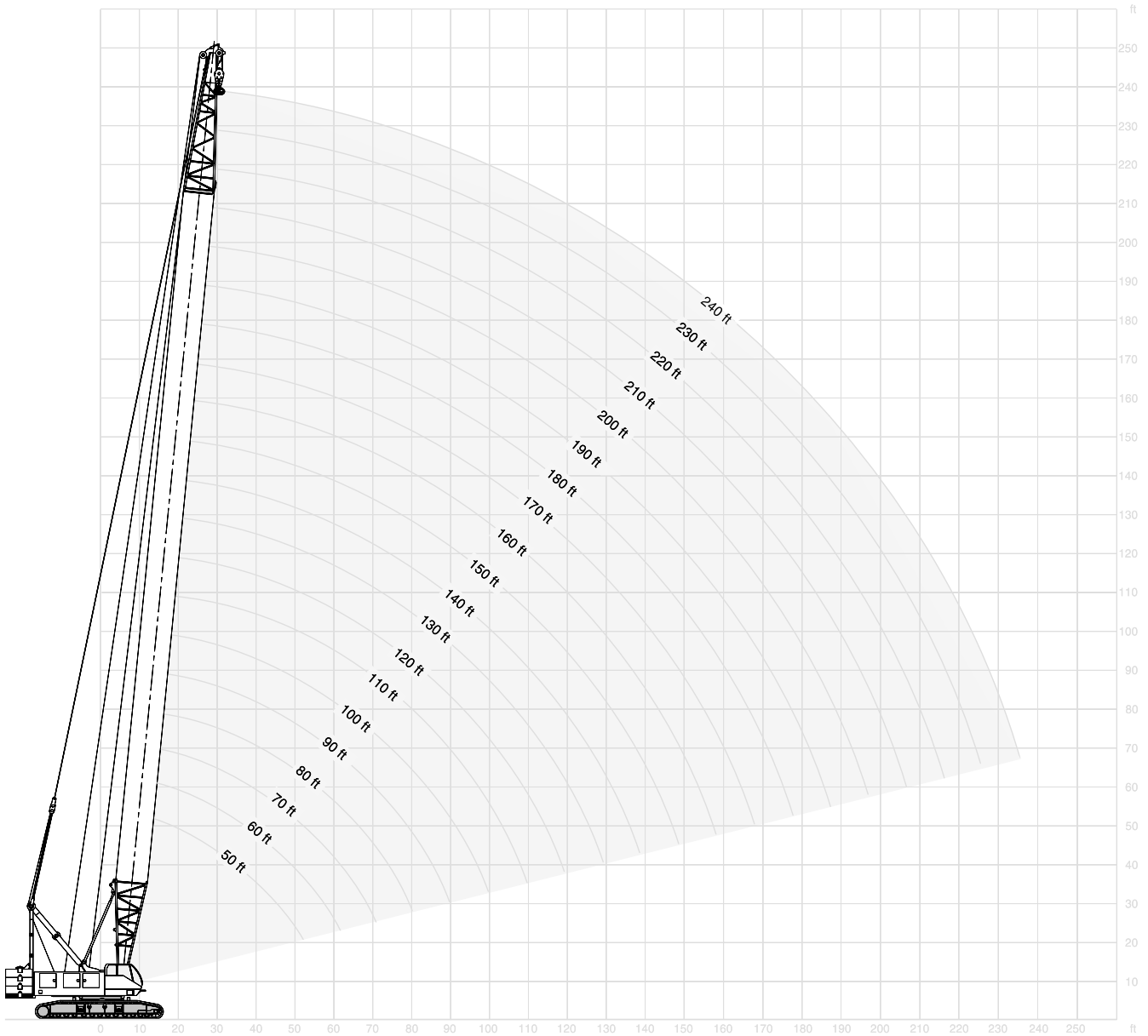

**WITH 77SI HAMMERHEAD TIP BOOM AND 102,000 POUND UPPER COUNTERWEIGHT**

102,000 lb 360° ANSI B 30.5

**50' (15.2 m) Boom length**

Radius (Feet)	Boom Angle (Degrees)	360 Degree Rating (Pounds)	From Boom Pt. to Ground (Feet)
14	81.9	330,000*	58
15	80.8	330,000*	57
20	75.0	270,720	56
25	68.9	183,870	55
30	62.7	138,290	52
35	55.9	110,230	49
40	48.5	91,140	45
50	29.5	66,900	32

**60' (18.3 m) Boom length**

15	82.3	330,000*	68
20	77.5	271,110	67
25	72.6	184,120	65
30	67.5	138,460	63
35	62.2	110,390	61
40	56.6	91,250	58
50	44.0	67,040	49
60	26.7	52,190	35

**70' (21.3 m) Boom length**

16	82.6	330,000*	78
20	79.3	271,310	77
25	75.1	184,230	76
30	70.8	138,520	74
35	66.5	110,420	72
40	61.9	91,260	70
50	52.0	67,060	63
60	40.5	52,210	53
70	24.6	42,200	37

**80' (24.4 m) Boom length**

17	82.8	330,000*	87
20	80.6	271,390	87
25	77.0	184,210	86
30	73.3	138,450	85
35	69.6	110,320	83
40	65.7	91,140	81
50	57.5	66,930	75
60	48.4	52,090	68
70	37.7	42,090	57
80	22.9	34,950	39

**90' (27.4 m) Boom length**

18	82.9	330,000*	97
20	81.7	271,410	97
25	78.5	184,130	96
30	75.2	138,330	95
35	71.9	110,190	94
40	68.5	90,980	92
50	61.5	66,770	87
60	53.9	51,910	81
70	45.4	41,920	72
80	35.4	34,840	60
90	21.5	29,360	40

**100' (30.5 m) Boom length**

Radius (Feet)	Boom Angle (Degrees)	360 Degree Rating (Pounds)	From Boom Pt. to Ground (Feet)
20	82.5	271,420	107
25	79.6	184,070	106
30	76.7	138,240	105
35	73.8	110,090	104
40	70.8	90,860	102
50	64.6	66,650	98
60	58.0	51,790	93
70	50.9	41,780	85
80	43.0	34,740	76
90	33.5	29,290	63
100	20.3	25,000	42

**110' (33.5 m) Boom length**

21	82.7	247,920	117
25	80.6	183,920	117
30	77.9	138,050	116
35	75.3	109,880	114
40	72.6	90,620	113
50	67.0	66,400	109
60	61.2	51,520	104
70	55.0	41,510	98
80	48.3	34,500	90
90	40.8	29,050	80
100	31.8	24,780	66
110	19.3	21,340	44

**120' (36.6 m) Boom length**

22	82.8	228,210	127
25	81.4	183,750	127
30	78.9	137,830	126
35	76.5	109,650	125
40	74.1	90,370	123
50	69.0	66,150	120
60	63.8	51,250	116
70	58.3	41,230	110
80	52.5	34,250	103
90	46.2	28,800	94
100	39.0	24,530	83
110	30.4	21,110	68
120	18.4	18,270	45

**130' (39.6 m) Boom length**

23	82.9	211,000	137
25	82.0	183,560	137
30	79.8	137,600	136
35	77.6	109,400	135
40	75.3	90,090	134
50	70.7	65,860	131
60	66.0	50,950	127
70	61.0	40,910	122
80	55.8	33,950	115
90	50.3	28,500	108
100	44.2	24,240	98
110	37.4	20,820	87
120	29.2	17,990	71
130	17.6	15,630	47



**WITH 77SI HAMMERHEAD TIP BOOM AND 102,000 POUND UPPER COUNTERWEIGHT**

102,000 lb 360° ANSI B 30.5

**140' (42.7 m) Boom length**

Radius (Feet)	Boom Angle (Degrees)	360 Degree Rating (Pounds)	From Boom Pt. to Ground (Feet)
25	82.6	183,360	147
30	80.5	137,350	146
35	78.5	109,150	145
40	76.4	89,800	144
50	72.1	65,570	141
60	67.8	50,640	138
70	63.3	40,590	133
80	58.6	33,650	127
90	53.6	28,200	121
100	48.3	23,940	112
110	42.5	20,510	102
120	35.9	17,700	90
130	28.0	15,350	73
140	17.0	13,350	48

**150' (45.7 m) Boom length**

26	82.7	171,730	157
30	81.2	137,140	156
35	79.2	108,910	155
40	77.3	89,550	154
50	73.3	65,320	152
60	69.3	50,370	148
70	65.2	40,320	144
80	60.9	33,390	139
90	56.4	27,940	133
100	51.7	23,670	126
110	46.6	20,260	117
120	41.0	17,450	106
130	34.7	15,100	93
140	27.1	13,100	76
150	16.4	11,380	50

**160' (48.8 m) Boom length**

27	82.8	161,670	167
30	81.7	136,880	166
35	79.9	108,640	166
40	78.1	89,260	165
50	74.4	65,010	162
60	70.7	50,040	159
70	66.8	40,320	155
80	62.9	33,070	150
90	58.8	27,610	145
100	54.5	23,350	138
110	49.9	19,920	130
120	45.0	17,110	121
130	39.6	14,760	110
140	33.5	12,770	96
150	26.2	11,060	78
160	15.8	9,570	51

**170' (51.8 m) Boom length**

Radius (Feet)	Boom Angle (Degrees)	360 Degree Rating (Pounds)	From Boom Pt. to Ground (Feet)
28	82.9	152,290	177
30	82.2	136,630	177
35	80.5	108,370	176
40	78.8	88,960	175
50	75.4	64,690	173
60	71.8	49,710	170
70	68.3	40,000	166
80	64.6	32,750	162
90	60.8	27,280	156
100	56.8	23,020	150
110	52.7	19,580	143
120	48.3	16,770	135
130	43.6	14,430	125
140	38.4	12,430	113
150	32.5	10,730	99
160	25.4	9,240	80
170	15.3	7,940	52

**180' (54.9 m) Boom length**

29	83.0	143,810	187
30	82.6	136,360	187
35	81.0	108,080	186
40	79.4	88,640	185
50	76.2	64,380	183
60	72.9	49,370	180
70	69.5	39,660	177
80	66.1	32,400	173
90	62.5	26,940	168
100	58.9	22,660	162
110	55.1	19,230	156
120	51.1	16,420	148
130	46.8	14,070	139
140	42.3	12,080	129
150	37.2	10,370	117
160	31.5	8,880	102
170	24.6	7,590	82
180	14.9	6,430	54

**190' (57.9 m) Boom length**

31	82.7	129,300	197
35	81.5	107,800	196
40	80.0	88,320	195
50	76.9	64,050	193
60	73.8	49,030	191
70	70.7	39,340	187
80	67.4	32,070	183
90	64.1	26,590	179
100	60.7	22,310	174
110	57.2	18,890	168
120	53.5	16,070	161
130	49.6	13,720	153
140	45.5	11,720	143
150	41.1	10,010	133
160	36.2	8,530	120
170	30.6	7,220	104
180	23.9	6,080	85
190	14.4	5,070	55

**WITH 77SI HAMMERHEAD TIP BOOM AND 102,000 POUND UPPER COUNTERWEIGHT**

102,000 lb 360° ANSI B 30.5

200' (61.0 m) Boom length			
Radius (Feet)	Boom Angle (Degrees)	360 Degree Rating (Pounds)	From Boom Pt. to Ground (Feet)
32	82.8	122,830	207
35	81.9	107,530	206
40	80.5	88,030	205
50	77.6	63,760	203
60	74.6	48,720	201
70	71.7	39,050	198
80	68.6	31,760	194
90	65.5	26,280	190
100	62.3	22,010	185
110	59.0	18,570	179
120	55.6	15,750	173
130	52.0	13,400	166
140	48.3	11,410	157
150	44.3	9,690	147
160	40.0	8,210	136
170	35.2	6,910	123
180	29.8	5,770	107
190	23.3	4,750	87
200	14.1	3,850	56

220' (67.1 m) Boom length			
Radius (Feet)	Boom Angle (Degrees)	360 Degree Rating (Pounds)	From Boom Pt. to Ground (Feet)
34	82.9	102,110 *	226
35	82.7	101,710 *	226
40	81.4	87,400	226
50	78.7	63,100	224
60	76.1	48,020	222
70	73.4	38,370	219
80	70.6	31,070	216
90	67.8	25,580	212
100	65.0	21,290	207
110	62.1	17,840	202
120	59.1	15,030	197
130	56.0	12,670	190
140	52.8	10,670	183
150	49.4	8,960	175
160	45.9	7,470	166
170	42.1	6,160	155
180	38.0	5,020	143
190	33.5	4,010	129
200	28.4	3,100	112

210' (64.0 m) Boom length			
Radius (Feet)	Boom Angle (Degrees)	360 Degree Rating (Pounds)	From Boom Pt. to Ground (Feet)
33	82.9	112,450 *	216
35	82.3	107,240	216
40	80.9	87,720	215
50	78.2	63,430	214
60	75.4	48,360	211
70	72.6	38,700	208
80	69.7	31,420	205
90	66.7	25,930	201
100	63.7	21,650	196
110	60.6	18,210	191
120	57.5	15,390	185
130	54.1	13,030	178
140	50.7	11,040	170
150	47.0	9,320	162
160	43.2	7,830	151
170	39.0	6,540	140
180	34.3	5,390	126
190	29.1	4,370	110
200	22.7	3,460	89

230' (70.1 m) Boom length			
Radius (Feet)	Boom Angle (Degrees)	360 Degree Rating (Pounds)	From Boom Pt. to Ground (Feet)
35	83.0	96,610 *	236
40	81.7	87,080	236
50	79.2	62,770	234
60	76.7	47,670	232
70	74.1	38,020	229
80	71.5	30,720	226
90	68.9	25,220	223
100	66.2	20,920	218
110	63.4	17,480	214
120	60.6	14,650	208
130	57.7	12,300	202
140	54.7	10,290	196
150	51.5	8,580	188
160	48.3	7,090	179
170	44.8	5,780	170
180	41.1	4,640	159
190	37.2	3,620	147

240' (73.2 m) Boom length			
Radius (Feet)	Boom Angle (Degrees)	360 Degree Rating (Pounds)	From Boom Pt. to Ground (Feet)
37	82.8	84,390 *	246
40	82.1	84,000 *	246
50	79.7	62,440	244
60	77.2	47,310	242
70	74.8	37,680	240
80	72.3	30,360	237
90	69.8	24,860	233
100	67.2	20,560	229
110	64.6	17,110	225
120	61.9	14,280	220
130	59.2	11,920	214
140	56.3	9,920	208
150	53.4	8,200	201
160	50.4	6,710	193
170	47.2	5,410	184
180	43.8	4,260	174
190	40.2	3,240	163



**WITH 77SI HAMMERHEAD TIP BOOM AND 116,400 POUND COUNTERWEIGHT**

108,400 lb + 8,000 lb carbody counterweight

360°

ANSI B 30.5

**50' (15.2 m) Boom length**

Radius (Feet)	Boom Angle (Degrees)	360 Degree Rating (Pounds)	From Boom Pt. to Ground (Feet)
14	81.9	330,000*	58
15	80.8	330,000*	57
20	75.0	285,140	56
25	68.9	193,760	55
30	62.7	145,760	52
35	55.9	116,200	49
40	48.5	96,080	45
50	29.5	70,550	32

**60' (18.3 m) Boom length**

15	82.3	330,000*	68
20	77.5	285,570	67
25	72.6	194,080	65
30	67.5	145,990	63
35	62.2	116,410	61
40	56.6	96,260	58
50	44.0	70,760	49
60	26.7	55,120	35

**70' (21.3 m) Boom length**

16	82.6	330,000*	78
20	79.3	285,800	77
25	75.1	194,230	76
30	70.8	146,080	74
35	66.5	116,490	72
40	61.9	96,310	70
50	52.0	70,820	63
60	40.5	55,190	53
70	24.6	44,650	37

**80' (24.4 m) Boom length**

17	82.8	330,000*	87
20	80.6	285,890	87
25	77.0	194,240	86
30	73.3	146,050	85
35	69.6	116,420	83
40	65.7	96,230	81
50	57.5	70,730	75
60	48.4	55,100	68
70	37.7	44,570	57
80	22.9	37,050	39

**90' (27.4 m) Boom length**

18	82.9	330,000*	97
20	81.7	285,910	97
25	78.5	194,190	96
30	75.2	145,960	95
35	71.9	116,320	94
40	68.5	96,090	92
50	61.5	70,590	87
60	53.9	54,950	81
70	45.4	44,430	72
80	35.4	36,960	60
90	21.5	31,200	40

**100' (30.5 m) Boom length**

Radius (Feet)	Boom Angle (Degrees)	360 Degree Rating (Pounds)	From Boom Pt. to Ground (Feet)
20	82.5	285,920	107
25	79.6	194,160	106
30	76.7	145,880	105
35	73.8	116,230	104
40	70.8	95,990	102
50	64.6	70,490	98
60	58.0	54,840	93
70	50.9	44,310	85
80	43.0	36,890	76
90	33.5	31,150	63
100	20.3	26,640	42

**110' (33.5 m) Boom length**

21	82.7	261,440	117
25	80.6	194,020	117
30	77.9	145,710	116
35	75.3	116,040	114
40	72.6	95,760	113
50	67.0	70,260	109
60	61.2	54,590	104
70	55.0	44,050	98
80	48.3	36,660	90
90	40.8	30,920	80
100	31.8	26,430	66
110	19.3	22,810	44

**120' (36.6 m) Boom length**

22	82.8	240,680	127
25	81.4	193,870	127
30	78.9	145,510	126
35	76.5	115,830	125
40	74.1	95,530	123
50	69.0	70,020	120
60	63.8	54,330	116
70	58.3	43,790	110
80	52.5	36,420	103
90	46.2	30,680	94
100	39.0	26,190	83
110	30.4	22,590	68
120	18.4	19,610	45

**130' (39.6 m) Boom length**

23	82.9	222,590	137
25	82.0	193,690	137
30	79.8	145,290	136
35	77.6	115,590	135
40	75.3	95,260	134
50	70.7	69,740	131
60	66.0	54,040	127
70	61.0	43,470	122
80	55.8	36,130	115
90	50.3	30,400	108
100	44.2	25,910	98
110	37.4	22,310	87
120	29.2	19,340	71
130	17.6	16,860	47

**WITH 77SI HAMMERHEAD TIP BOOM AND 116,400 POUND COUNTERWEIGHT**

108,400 lb + 8,000 lb carbody counterweight

360°

**ANSI B 30.5**

<b>140' (42.7 m) Boom length</b>			
Radius (Feet)	Boom Angle (Degrees)	360 Degree Rating (Pounds)	From Boom Pt. to Ground (Feet)
25	82.6	193,500	147
30	80.5	145,050	146
35	78.5	115,340	145
40	76.4	94,980	144
50	72.1	69,460	141
60	67.8	53,740	138
70	63.3	43,170	133
80	58.6	35,840	127
90	53.6	30,110	121
100	48.3	25,630	112
110	42.5	22,020	102
120	35.9	19,060	90
130	28.0	16,590	73
140	17.0	14,480	48

<b>150' (45.7 m) Boom length</b>			
Radius (Feet)	Boom Angle (Degrees)	360 Degree Rating (Pounds)	From Boom Pt. to Ground (Feet)
26	82.7	181,270	157
30	81.2	144,850	156
35	79.2	115,120	155
40	77.3	94,740	154
50	73.3	69,210	152
60	69.3	53,480	148
70	65.2	42,900	144
80	60.9	35,600	139
90	56.4	29,860	133
100	51.7	25,370	126
110	46.6	21,780	117
120	41.0	18,810	106
130	34.7	16,340	93
140	27.1	14,240	76
150	16.4	12,440	50

<b>160' (48.8 m) Boom length</b>			
Radius (Feet)	Boom Angle (Degrees)	360 Degree Rating (Pounds)	From Boom Pt. to Ground (Feet)
27	82.8	170,310	167
30	81.7	144,600	166
35	79.9	114,850	166
40	78.1	94,450	165
50	74.4	68,910	162
60	70.7	53,160	159
70	66.8	42,570	155
80	62.9	35,280	150
90	58.8	29,530	145
100	54.5	25,050	138
110	49.9	21,440	130
120	45.0	18,490	121
130	39.6	16,010	110
140	33.5	13,910	96
150	26.2	12,120	78
160	15.8	10,550	51

<b>170' (51.8 m) Boom length</b>			
Radius (Feet)	Boom Angle (Degrees)	360 Degree Rating (Pounds)	From Boom Pt. to Ground (Feet)
28	82.9	160,840	177
30	82.2	144,350	177
35	80.5	114,590	176
40	78.8	94,160	175
50	75.4	68,600	173
60	71.8	52,840	170
70	68.3	42,230	166
80	64.6	34,960	162
90	60.8	29,210	156
100	56.8	24,720	150
110	52.7	21,110	143
120	48.3	18,150	135
130	43.6	15,690	125
140	38.4	13,590	113
150	32.5	11,790	99
160	25.4	10,230	80
170	15.3	8,860	52

<b>180' (54.9 m) Boom length</b>			
Radius (Feet)	Boom Angle (Degrees)	360 Degree Rating (Pounds)	From Boom Pt. to Ground (Feet)
29	83.0	151,930	187
30	82.6	144,080	187
35	81.0	114,310	186
40	79.4	93,850	185
50	76.2	68,290	183
60	72.9	52,500	180
70	69.5	41,870	177
80	66.1	34,620	173
90	62.5	28,870	168
100	58.9	24,380	162
110	55.1	20,760	156
120	51.1	17,800	148
130	46.8	15,330	139
140	42.3	13,240	129
150	37.2	11,440	117
160	31.5	9,880	102
170	24.6	8,510	82
180	14.9	7,300	54

<b>190' (57.9 m) Boom length</b>			
Radius (Feet)	Boom Angle (Degrees)	360 Degree Rating (Pounds)	From Boom Pt. to Ground (Feet)
31	82.7	136,680	197
35	81.5	114,030	196
40	80.0	93,530	195
50	76.9	67,970	193
60	73.8	52,160	191
70	70.7	41,530	187
80	67.4	34,300	183
90	64.1	28,530	179
100	60.7	24,030	174
110	57.2	20,430	168
120	53.5	17,460	161
130	49.6	14,990	153
140	45.5	12,890	143
150	41.1	11,090	133
160	36.2	9,530	120
170	30.6	8,160	104
180	23.9	6,960	85
190	14.4	5,890	55



**WITH 77SI HAMMERHEAD TIP BOOM AND 116,400 POUND COUNTERWEIGHT**

108,400 lb + 8,000 lb carbody counterweight

360°

ANSI B 30.5

200' (61.0 m) Boom length			
Radius (Feet)	Boom Angle (Degrees)	360 Degree Rating (Pounds)	From Boom Pt. to Ground (Feet)
32	82.8	126,040*	207
35	81.9	113,770	206
40	80.5	93,250	205
50	77.6	67,690	203
60	74.6	51,850	201
70	71.7	41,220	198
80	68.6	33,990	194
90	65.5	28,230	190
100	62.3	23,730	185
110	59.0	20,120	179
120	55.6	17,150	173
130	52.0	14,680	166
140	48.3	12,580	157
150	44.3	10,770	147
160	40.0	9,220	136
170	35.2	7,850	123
180	29.8	6,650	107
190	23.3	5,580	87
200	14.1	4,620	56

220' (67.1 m) Boom length			
Radius (Feet)	Boom Angle (Degrees)	360 Degree Rating (Pounds)	From Boom Pt. to Ground (Feet)
34	82.9	102,050*	226
35	82.7	101,650*	226
40	81.4	92,630	226
50	78.7	67,030	224
60	76.1	51,160	222
70	73.4	40,500	219
80	70.6	33,310	216
90	67.8	27,530	212
100	65.0	23,020	207
110	62.1	19,400	202
120	59.1	16,430	197
130	56.0	13,950	190
140	52.8	11,850	183
150	49.4	10,050	175
160	45.9	8,480	166
170	42.1	7,110	155
180	38.0	5,900	143
190	33.5	4,840	129
200	28.4	3,880	112
210	22.2	3,020	91

210' (64.0 m) Boom length			
Radius (Feet)	Boom Angle (Degrees)	360 Degree Rating (Pounds)	From Boom Pt. to Ground (Feet)
33	82.9	112,390*	216
35	82.3	112,030*	216
40	80.9	92,940	215
50	78.2	67,360	214
60	75.4	51,510	211
70	72.6	40,860	208
80	69.7	33,660	205
90	66.7	27,880	201
100	63.7	23,370	196
110	60.6	19,750	191
120	57.5	16,790	185
130	54.1	14,310	178
140	50.7	12,210	170
150	47.0	10,410	162
160	43.2	8,840	151
170	39.0	7,480	140
180	34.3	6,270	126
190	29.1	5,200	110
200	22.7	4,240	89
210	13.7	3,390	57

230' (70.1 m) Boom length			
Radius (Feet)	Boom Angle (Degrees)	360 Degree Rating (Pounds)	From Boom Pt. to Ground (Feet)
35	83.0	92,560*	236
40	81.7	92,150*	236
50	79.2	66,710	234
60	76.7	50,820	232
70	74.1	40,130	229
80	71.5	32,960	226
90	68.9	27,180	223
100	66.2	22,660	218
110	63.4	19,030	214
120	60.6	16,060	208
130	57.7	13,580	202
140	54.7	11,470	196
150	51.5	9,670	188
160	48.3	8,110	179
170	44.8	6,730	170
180	41.1	5,530	159
190	37.2	4,460	147
200	32.8	3,490	132

240' (73.2 m) Boom length			
Radius (Feet)	Boom Angle (Degrees)	360 Degree Rating (Pounds)	From Boom Pt. to Ground (Feet)
37	82.8	84,340*	246
40	82.1	83,950*	246
50	79.7	66,380	244
60	77.2	50,470	242
70	74.8	40,310	240
80	72.3	32,610	237
90	69.8	26,820	233
100	67.2	22,290	229
110	64.6	18,670	225
120	61.9	15,690	220
130	59.2	13,210	214
140	56.3	11,100	208
150	53.4	9,300	201
160	50.4	7,730	193
170	47.2	6,360	184
180	43.8	5,150	174
190	40.2	4,080	163
200	36.3	3,120	150

**NOTES TO LIFTING CAPACITY**

**⚠ Warning**

This rating chart is invalid if the crane has been modified or altered by use of other than GENUINE AMERICAN PARTS as such modifications or alterations may affect its capacity or safe operation. See American Crane Corporation Service Bulliten #259.

Ratings in this chart are in POUNDS and do not exceed the percentage of tipping specified for this crane by ANSI B30.5. All ratings require that the crane be standing level on a firm uniformly supporting surface.

Do not lift loads in excess of those shown on this chart. Lifting loads in excess of those shown or operation not in accordance with good operating practice, including limitations shown on page 3499 of Operator's Manual, can cause tipping, structural damage or catastrophic failure.

Asterisk (\*) areas on this chart indicate ratings which are limited by strength of material or factors other than stability (tipping).

„RADIUS IN FEET“ is the horizontal distance at ground level from the crane centerline of rotation to a vertical line through the center of gravity of the suspended load.

When using the main boom fall with jib in place, the main fall ratings must be reduced by the jib effective weight shown on the jib rating chart plus twice the weight of all suspended blocks, slings, rope, etc., at the jib fall. See Appendix A.

When using the main boom fall with boom tip extension in place, the main fall ratings must be reduced by the weight of the boom tip extension plus twice the weight of all suspended blocks, slings, rope, etc., at the boom tip extension fall. See Appendix A.

Blocks, slings, buckets and other load carrying devices are considered part of the load. The weight of standard hoisting ropes for the rating at a given radius has been calculated as part of the boom point load and need not be considered in determining net allowable loads. See Appendix A.

This chart was developed exclusively for use with a boom only. Under no circumstances are these ratings to be interpreted for use with a jib.

Ratings shown on this chart make no allowance for such factors as out of plumb loads, wind, poor soil conditions, improper inflation of rubber tires and dynamic effects due to excessive operating speeds. The user (operator) must exercise judgement to make allowance for these conditions. See page 3499 of Operator's Manual for detailed information.

No account is taken of the wind force on the load. This effect, which can be substantial for loads with large surface areas, must be considered by the user. In any wind it is strongly recommended that taglines be used to control the load.

BOOM HOIST LINE is 14 parts of 7/8 inch diameter EIPS wire rope with a minimum breaking strength of 79,600 pound.

PENDANT SUSPENSION LINE is 4 parts of 1.375 inch diameter EEIPS wire rope with a minimum breaking strength of 211,000 pound.

MAIN LOAD LINE – 1.125 inch diameter EIPS wire rope with a minimum breaking strength of 130,000 pound.

ALTERNATE LOAD LINE (ROTATION RESISTANT) – 1.125 inch diameter BRIDON ENDURANCE DYFORM 34LR Grade 2160 wire rope with a minimum breaking strength of 167,200 pound.

**ERECTION**

Erection „OVER THE END“ is with the boom over the idler end with idler tumblers blocked (See operator's manual for blocking instructions). Erection „OVER THE SIDE“ is with the boom 90° to the sideframes and with the side frames extended. Blocks, slings and other load carrying devices must be on the ground during erection.

77SI HAMMERHEAD BOOM MAXIMUM BOOM & JIB SELF-ERECTION DATA				
	OVER THE END		OVER THE SIDE	
	BOOM LENGTH (FEET)	JIB LENGTH (FEET)	BOOM LENGTH (FEET)	JIB LENGTH (FEET)
#16HL JIB	240	0	220	0
	230	0	210	40
	220	80	200	80

LOAD HOISTING INFORMATION - 1.125 inch diameter EIPS wire rope			
MAXIMUM LIFTING CAPACITY - LBS.	MINIMUM PARTS OF LINE	MAXIMUM HOISTING DISTANCE - FEET	
		MAIN - (FRONT)	AUX. - (REAR)
330,000	9	145	145
297,120	8	164	164
259,980	7	187	187
222,840	6	218	218
185,700	5	262	262
148,560	4	328	328
111,420	3	437	437
74,280	2	656	656
37,140	1	1,312	1,312

LOAD HOISTING INFORMATION (ROTATION RESISTANT LOAD LINE) 1.125 inch diameter BRIDON ENDURANCE DYFORM 34LR Grade 2160 wire rope			
MAXIMUM LIFTING CAPACITY - LBS.	MINIMUM PARTS OF LINE	MAXIMUM HOISTING DISTANCE - FEET	
		MAIN - (FRONT)	AUX. - (REAR)
330,000	10	131	131
300,960	9	145	145
267,520	8	164	164
234,080	7	187	187
200,640	6	218	218
167,200	5	262	262
133,760	4	328	328
100,320	3	437	437
66,880	2	656	656
33,440	1	1,312	1,312

77SI HAMMERHEAD BOOM COMPOSITION CHART							
BOOM LENGTH (METERS)	BOOM LENGTH (FEET)	BOOM SECTIONS					
		9.1 M 30' 77SI INNER	3.0 M 10' 77S CENTER	6.1 M 20' 77S CENTER	15.2 M 50' 77S CENTER	5.9 M 19.5' 77HL OUTER	0 M 0' HAMMER HEAD
15.2 M	50	1	0	0	0	1	1
18.3 M	60	1	1	0	0	1	1
21.3 M	70	1	0	1	0	1	1
24.4 M	80	1	1	1	0	1	1
27.4 M	90	1	0	2	0	1	1
30.5 M	100	1	0	0	1	1	1
33.5 M	110	1	1	0	1	1	1
36.6 M	120	1	0	1	1	1	1
39.6 M	130	1	1	1	1	1	1
42.7 M	140	1	0	2	1	1	1
45.7 M	150	1	0	0	2	1	1
48.8 M	160	1	1	0	2	1	1
51.8 M	170	1	0	1	2	1	1
54.9 M	180	1	1	1	2	1	1
57.9 M	190	1	0	2	2	1	1
61.0 M	200	1	0	0	3	1	1
64.0 M	210	1	1	0	3	1	1
67.1 M	220	1	0	1	3	1	1
70.1 M	230	1	1	1	3	1	1
73.2 M	240	1	0	2	3	1	1

**RANGE DIAGRAM, 77SI OFFSET TIP BOOM**

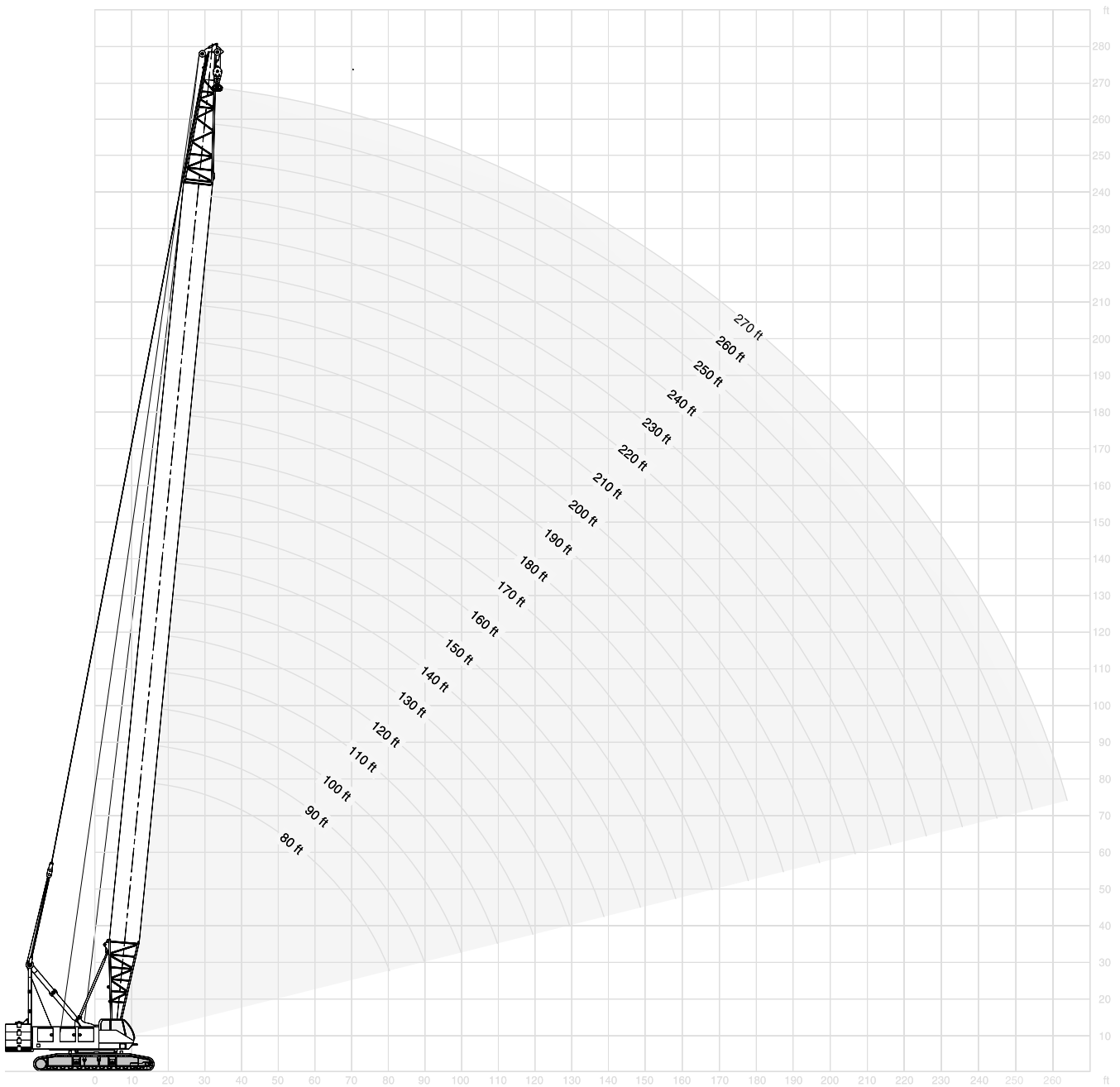

**WITH 77SI OFFSET TIP BOOM AND 102,000 POUND UPPER COUNTERWEIGHT**

102,000 lb

360°

ANSI B 30.5

80' (24.4 m) Boom length			
Radius (Feet)	Boom Angle (Degrees)	360 Degree Rating (Pounds)	From Boom Pt. to Ground (Feet)
17	81.0	235,130 *	86
20	78.8	235,130 *	86
25	75.1	184,750	84
30	71.4	139,390	83
35	67.5	111,510	81
40	63.6	92,490	79
50	55.3	68,510	73
60	46.0	53,820	65
70	35.0	43,940	53
80	19.2	36,910	33

90' (27.4 m) Boom length			
Radius (Feet)	Boom Angle (Degrees)	360 Degree Rating (Pounds)	From Boom Pt. to Ground (Feet)
19	80.7	234,610 *	96
20	80.0	230,880 *	96
25	76.8	184,680	95
30	73.5	139,270	93
35	70.1	111,380	92
40	66.7	92,330	90
50	59.6	68,350	85
60	51.9	53,640	78
70	43.2	43,750	69
80	32.9	36,750	56
90	18.0	31,380	35

100' (30.5 m) Boom length			
Radius (Feet)	Boom Angle (Degrees)	360 Degree Rating (Pounds)	From Boom Pt. to Ground (Feet)
21	80.5	221,940 *	106
25	78.1	184,560	105
30	75.2	139,120	104
35	72.2	111,220	102
40	69.2	92,150	101
50	62.9	68,150	96
60	56.2	53,430	90
70	49.0	43,530	83
80	40.9	36,570	73
90	31.2	31,180	59
100	17.1	26,980	37

110' (33.5 m) Boom length			
Radius (Feet)	Boom Angle (Degrees)	360 Degree Rating (Pounds)	From Boom Pt. to Ground (Feet)
22	80.8	213,950 *	116
25	79.2	184,380	115
30	76.6	138,910	114
35	73.9	110,990	113
40	71.1	91,900	111
50	65.5	67,910	107
60	59.7	53,160	102
70	53.4	43,260	95
80	46.6	36,310	87
90	38.9	30,930	76
100	29.7	26,720	62
110	16.3	23,360	38

120' (36.6 m) Boom length			
Radius (Feet)	Boom Angle (Degrees)	360 Degree Rating (Pounds)	From Boom Pt. to Ground (Feet)
24	80.6	196,990	125
25	80.1	184,190	125
30	77.7	138,670	124
35	75.2	110,750	123
40	72.8	91,640	122
50	67.7	67,650	118
60	62.4	52,890	113
70	56.9	42,970	108
80	51.0	36,050	100
90	44.5	30,660	91
100	37.2	26,460	80
110	28.4	23,090	64
120	15.6	20,330	39

130' (39.6 m) Boom length			
Radius (Feet)	Boom Angle (Degrees)	360 Degree Rating (Pounds)	From Boom Pt. to Ground (Feet)
25	80.9	184,010	135
30	78.7	138,480	135
35	76.4	110,550	133
40	74.1	91,420	132
50	69.5	67,430	129
60	64.7	52,660	125
70	59.7	42,730	119
80	54.5	35,840	113
90	48.8	30,450	105
100	42.7	26,250	95
110	35.7	22,870	83
120	27.3	20,100	67
130	15.0	17,800	41

140' (42.7 m) Boom length			
Radius (Feet)	Boom Angle (Degrees)	360 Degree Rating (Pounds)	From Boom Pt. to Ground (Feet)
27	80.7	162,360	145
30	79.5	138,200	145
35	77.4	110,270	144
40	75.3	91,110	143
50	71.0	67,120	139
60	66.6	52,340	136
70	62.1	42,400	131
80	57.3	35,540	125
90	52.3	30,140	118
100	47.0	25,930	109
110	41.1	22,560	99
120	34.4	19,790	86
130	26.2	17,480	69
140	14.4	15,530	42

150' (45.7 m) Boom length			
Radius (Feet)	Boom Angle (Degrees)	360 Degree Rating (Pounds)	From Boom Pt. to Ground (Feet)
28	81.0	153,400	155
30	80.2	137,920	155
35	78.2	109,970	154
40	76.3	90,810	153
50	72.3	66,810	150
60	68.3	52,020	146
70	64.1	42,070	142
80	59.7	35,220	137
90	55.2	29,820	130
100	50.4	25,610	123
110	45.3	22,230	114
120	39.6	19,470	103
130	33.2	17,160	89
140	25.3	15,200	71
150	14.0	13,530	43



**WITH 77SI OFFSET TIP BOOM AND 102,000 POUND UPPER COUNTERWEIGHT**

102,000 lb

360°

ANSI B 30.5

**160' (48.8 m) Boom length**

Radius (Feet)	Boom Angle (Degrees)	360 Degree Rating (Pounds)	From Boom Pt. to Ground (Feet)
30	80.8	137,620	165
35	79.0	109,670	164
40	77.2	90,480	163
50	73.4	66,480	160
60	69.7	51,680	157
70	65.8	41,720	153
80	61.8	34,880	148
90	57.7	29,490	142
100	53.3	25,270	135
110	48.7	21,890	127
120	43.8	19,120	118
130	38.3	16,810	106
140	32.1	14,840	92
150	24.5	13,180	74
160	13.5	11,720	44

**190' (57.9 m) Boom length**

Radius (Feet)	Boom Angle (Degrees)	360 Degree Rating (Pounds)	From Boom Pt. to Ground (Feet)
35	80.7	108,760	195
40	79.2	89,520	194
50	76.1	65,520	192
60	73.0	50,660	189
70	69.8	40,670	185
80	66.6	33,900	181
90	63.2	28,490	177
100	59.8	24,280	171
110	56.3	20,880	165
120	52.5	18,110	158
130	48.6	15,790	150
140	44.5	13,830	140
150	40.0	12,150	129
160	35.0	10,690	116
170	29.4	9,410	100
180	22.5	8,300	80
190	12.4	7,330	48

**170' (51.8 m) Boom length**

32	80.7	124,500	175
35	79.6	109,360	174
40	77.9	90,150	173
50	74.4	66,150	171
60	70.9	51,330	168
70	67.3	41,360	164
80	63.6	34,560	159
90	59.8	29,150	154
100	55.8	24,930	148
110	51.6	21,550	140
120	47.2	18,780	132
130	42.4	16,460	122
140	37.1	14,500	110
150	31.1	12,830	95
160	23.8	11,370	76
170	13.1	10,110	46

**200' (61.0 m) Boom length**

36	80.9	104,020	205
40	79.8	89,170	204
50	76.8	65,180	202
60	73.9	50,310	199
70	70.9	40,310	196
80	67.8	33,560	192
90	64.7	28,150	188
100	61.5	23,920	183
110	58.1	20,520	177
120	54.7	17,750	170
130	51.1	15,430	163
140	47.3	13,470	154
150	43.3	11,780	144
160	38.9	10,320	133
170	34.1	9,050	119
180	28.6	7,930	103
190	21.9	6,940	82
200	12.1	6,060	49

**180' (54.9 m) Boom length**

33	80.9	119,010	185
35	80.2	109,080	184
40	78.6	89,860	184
50	75.3	65,860	181
60	72.0	51,030	178
70	68.6	41,040	175
80	65.2	34,260	170
90	61.6	28,850	165
100	57.9	24,630	160
110	54.1	21,250	153
120	50.0	18,470	145
130	45.8	16,160	136
140	41.1	14,190	126
150	36.0	12,510	113
160	30.2	11,060	98
170	23.1	9,800	78
180	12.7	8,690	47

**210' (64.0 m) Boom length**

38	80.8	95,740	214
40	80.3	88,820	214
50	77.5	64,820	212
60	74.7	49,940	210
70	71.8	40,390	207
80	68.9	33,190	203
90	65.9	27,770	199
100	62.9	23,540	194
110	59.8	20,160	189
120	56.6	17,370	182
130	53.3	15,050	175
140	49.8	13,090	167
150	46.1	11,400	158
160	42.2	9,940	148
170	38.0	8,660	136
180	33.3	7,530	122
190	27.9	6,540	105
200	21.4	5,660	84
210	11.8	4,880	50

**WITH 77SI OFFSET TIP BOOM AND 102,000 POUND UPPER COUNTERWEIGHT**

102,000 lb

360°

ANSI B 30.5

220' (67.1 m) Boom length			
Radius (Feet)	Boom Angle (Degrees)	360 Degree Rating (Pounds)	From Boom Pt. to Ground (Feet)
39	81.0	91,810	224
40	80.7	88,470	224
50	78.1	64,470	222
60	75.4	49,570	220
70	72.7	40,040	217
80	69.9	32,840	214
90	67.1	27,420	210
100	64.2	23,180	205
110	61.3	19,790	200
120	58.3	17,000	194
130	55.2	14,680	188
140	52.0	12,710	180
150	48.6	11,030	172
160	45.0	9,560	163
170	41.2	8,280	152
180	37.1	7,150	140
190	32.5	6,160	125
200	27.3	5,270	108
210	20.9	4,480	85
220	11.5	3,780	51

250' (76.2 m) Boom length			
Radius (Feet)	Boom Angle (Degrees)	360 Degree Rating (Pounds)	From Boom Pt. to Ground (Feet)
44	80.9	74,200*	254
50	79.5	63,430	253
60	77.2	48,490	251
70	74.8	39,010	248
80	72.4	31,780	245
90	70.0	26,340	242
100	67.5	22,100	238
110	65.0	18,690	234
120	62.5	15,900	229
130	59.8	13,580	223
140	57.2	11,600	217
150	54.4	9,920	210
160	51.5	8,440	203
170	48.5	7,160	194
180	45.4	6,040	185
190	42.1	5,030	175
200	38.5	4,140	163
210	34.7	3,330	149
220	30.4	2,610	134

230' (70.1 m) Boom length			
Radius (Feet)	Boom Angle (Degrees)	360 Degree Rating (Pounds)	From Boom Pt. to Ground (Feet)
41	80.8	85,000	234
50	78.6	64,140	233
60	76.0	49,230	230
70	73.4	39,720	228
80	70.8	32,510	224
90	68.2	27,080	221
100	65.4	22,850	216
110	62.7	19,450	211
120	59.8	16,670	206
130	56.9	14,340	200
140	53.9	12,370	193
150	50.7	10,690	185
160	47.4	9,220	177
170	44.0	7,940	167
180	40.2	6,810	156
190	36.2	5,810	143
200	31.7	4,920	128
210	26.6	4,120	110
220	20.4	3,410	87
230	11.3	2,790	52

260' (79.2 m) Boom length			
Radius (Feet)	Boom Angle (Degrees)	360 Degree Rating (Pounds)	From Boom Pt. to Ground (Feet)
46	80.8	68,160*	264
50	79.9	63,560	263
60	77.7	48,610	261
70	75.4	39,130	259
80	73.1	31,910	256
90	70.8	26,460	253
100	68.4	22,220	249
110	66.0	18,810	245
120	63.6	16,020	240
130	61.1	13,680	235
140	58.6	11,710	229
150	56.0	10,020	223
160	53.3	8,540	215
170	50.5	7,260	208
180	47.5	6,130	199
190	44.5	5,130	189
200	41.2	4,230	178
210	37.7	3,420	166
220	34.0	2,700	152

240' (73.2 m) Boom length			
Radius (Feet)	Boom Angle (Degrees)	360 Degree Rating (Pounds)	From Boom Pt. to Ground (Feet)
42	81.0	81,680	244
50	79.1	63,790	243
60	76.6	48,860	241
70	74.1	39,360	238
80	71.7	32,150	235
90	69.1	26,710	231
100	66.5	22,480	227
110	63.9	19,070	223
120	61.2	16,280	217
130	58.5	13,950	212
140	55.6	11,990	205
150	52.7	10,300	198
160	49.6	8,830	190
170	46.4	7,550	181
180	43.0	6,420	171
190	39.4	5,420	159
200	35.4	4,530	146
210	31.1	3,720	131
220	26.1	3,000	113

270' (82.3 m) Boom length			
Radius (Feet)	Boom Angle (Degrees)	360 Degree Rating (Pounds)	From Boom Pt. to Ground (Feet)
47	80.9	62,440*	274
50	80.3	61,770*	273
60	78.1	48,230	271
70	75.9	38,770	269
80	73.8	31,540	266
90	71.5	26,090	263
100	69.3	21,840	260
110	67.0	18,430	256
120	64.7	15,630	251
130	62.3	13,290	246
140	59.9	11,330	241
150	57.4	9,630	235
160	54.8	8,160	228
170	52.2	6,870	220
180	49.4	5,740	212
190	46.6	4,730	203
200	43.6	3,840	193
210	40.4	3,030	182



**WITH 77SI OFFSET TIP BOOM AND 116,400 POUND COUNTERWEIGHT**

108,400 lb + 8,000 lb carbony counterweight

360°

**ANSI B 30.5**

**80' (24.4 m) Boom length**

Radius (Feet)	Boom Angle (Degrees)	360 Degree Rating (Pounds)	From Boom Pt. to Ground (Feet)
17	81.0	235,130 *	86
20	78.8	235,130 *	86
25	75.1	195,140	84
30	71.4	147,300	83
35	67.5	117,910	81
40	63.6	97,850	79
50	55.3	72,560	73
60	46.0	57,080	65
70	35.0	46,660	53
80	19.1	39,250	33

**90' (27.4 m) Boom length**

Radius (Feet)	Boom Angle (Degrees)	360 Degree Rating (Pounds)	From Boom Pt. to Ground (Feet)
19	80.7	234,610 *	96
20	80.0	230,880 *	96
25	76.8	195,060	95
30	73.5	147,180	93
35	70.1	117,770	92
40	66.7	97,690	90
50	59.6	72,410	85
60	51.9	56,900	78
70	43.2	46,470	69
80	32.9	39,100	56
90	18.0	33,430	35

**100' (30.5 m) Boom length**

Radius (Feet)	Boom Angle (Degrees)	360 Degree Rating (Pounds)	From Boom Pt. to Ground (Feet)
21	80.5	221,940 *	106
25	78.1	194,940	105
30	75.2	147,040	104
35	72.2	117,610	102
40	69.2	97,510	101
50	62.9	72,210	96
60	56.2	56,690	90
70	49.0	46,260	83
80	40.9	38,910	73
90	31.2	33,240	59
100	17.1	28,810	37

**110' (33.5 m) Boom length**

Radius (Feet)	Boom Angle (Degrees)	360 Degree Rating (Pounds)	From Boom Pt. to Ground (Feet)
22	80.8	213,950 *	116
25	79.2	194,760	115
30	76.6	146,820	114
35	73.9	117,380	113
40	71.1	97,260	111
50	65.5	71,960	107
60	59.7	56,420	102
70	53.4	45,980	95
80	46.6	38,650	87
90	38.9	32,980	76
100	29.7	28,550	62
110	16.3	25,000	38

**120' (36.6 m) Boom length**

Radius (Feet)	Boom Angle (Degrees)	360 Degree Rating (Pounds)	From Boom Pt. to Ground (Feet)
24	80.6	201,030 *	125
25	80.1	194,570	125
30	77.7	146,580	124
35	75.2	117,140	123
40	72.8	97,000	122
50	67.7	71,700	118
60	62.4	56,150	113
70	56.9	45,700	108
80	51.0	38,390	100
90	44.5	32,720	91
100	37.2	28,290	80
110	28.4	24,740	64
120	15.6	21,830	39

**130' (39.6 m) Boom length**

Radius (Feet)	Boom Angle (Degrees)	360 Degree Rating (Pounds)	From Boom Pt. to Ground (Feet)
25	80.9	192,950 *	135
30	78.7	146,390	135
35	76.4	116,940	133
40	74.1	96,780	132
50	69.5	71,480	129
60	64.7	55,920	125
70	59.7	45,460	119
80	54.5	38,180	113
90	48.8	32,500	105
100	42.7	28,080	95
110	35.7	24,520	83
120	27.3	21,600	67
130	15.0	19,170	41

**140' (42.7 m) Boom length**

Radius (Feet)	Boom Angle (Degrees)	360 Degree Rating (Pounds)	From Boom Pt. to Ground (Feet)
27	80.7	171,590	145
30	79.5	146,110	145
35	77.4	116,660	144
40	75.3	96,470	143
50	71.0	71,180	139
60	66.6	55,600	136
70	62.1	45,130	131
80	57.3	37,880	125
90	52.3	32,190	118
100	47.0	27,760	109
110	41.1	24,200	99
120	34.4	21,290	86
130	26.2	18,850	69
140	14.4	16,800	42

**150' (45.7 m) Boom length**

Radius (Feet)	Boom Angle (Degrees)	360 Degree Rating (Pounds)	From Boom Pt. to Ground (Feet)
28	81.0	161,800	155
30	80.2	145,830	155
35	78.2	116,360	154
40	76.3	96,170	153
50	72.3	70,870	150
60	68.3	55,280	146
70	64.1	44,800	142
80	59.7	37,570	137
90	55.2	31,880	130
100	50.4	27,440	123
110	45.3	23,880	114
120	39.6	20,970	103
130	33.2	18,530	89
140	25.3	16,470	71
150	14.0	14,710	43

**WITH 77SI OFFSET TIP BOOM AND 116,400 POUND COUNTERWEIGHT**

108,400 lb + 8,000 lb carbody counterweight

360°

ANSI B 30.5

160' (48.8 m) Boom length			
Radius (Feet)	Boom Angle (Degrees)	360 Degree Rating (Pounds)	From Boom Pt. to Ground (Feet)
30	80.8	145,530	165
35	79.0	116,060	164
40	77.2	95,840	163
50	73.4	70,540	160
60	69.7	54,940	157
70	65.8	44,450	153
80	61.8	37,230	148
90	57.7	31,540	142
100	53.3	27,100	135
110	48.7	23,540	127
120	43.8	20,610	118
130	38.3	18,180	106
140	32.1	16,110	92
150	24.5	14,350	74
160	13.5	12,830	44

190' (57.9 m) Boom length			
Radius (Feet)	Boom Angle (Degrees)	360 Degree Rating (Pounds)	From Boom Pt. to Ground (Feet)
35	80.7	115,150	195
40	79.2	94,880	194
50	76.1	69,580	192
60	73.0	53,930	189
70	69.8	43,400	185
80	66.6	36,250	181
90	63.2	30,540	177
100	59.8	26,100	171
110	56.3	22,530	165
120	52.5	19,610	158
130	48.6	17,170	150
140	44.5	15,100	140
150	40.0	13,330	129
160	35.0	11,790	116
170	29.4	10,440	100
180	22.5	9,270	80
190	12.4	8,240	48

170' (51.8 m) Boom length			
Radius (Feet)	Boom Angle (Degrees)	360 Degree Rating (Pounds)	From Boom Pt. to Ground (Feet)
32	80.7	131,730	175
35	79.6	115,750	174
40	77.9	95,510	173
50	74.4	70,210	171
60	70.9	54,590	168
70	67.3	44,080	164
80	63.6	36,900	159
90	59.8	31,200	154
100	55.8	26,760	148
110	51.6	23,200	140
120	47.2	20,270	132
130	42.4	17,830	122
140	37.1	15,770	110
150	31.1	14,000	95
160	23.8	12,470	76
170	13.1	11,140	46

200' (61.0 m) Boom length			
Radius (Feet)	Boom Angle (Degrees)	360 Degree Rating (Pounds)	From Boom Pt. to Ground (Feet)
36	80.9	110,170	205
40	79.8	94,530	204
50	76.8	69,230	202
60	73.9	53,570	199
70	70.9	43,030	196
80	67.8	35,900	192
90	64.7	30,200	188
100	61.5	25,750	183
110	58.1	22,170	177
120	54.7	19,250	170
130	51.1	16,810	163
140	47.3	14,740	154
150	43.3	12,960	144
160	38.9	11,430	133
170	34.1	10,080	119
180	28.6	8,900	103
190	21.9	7,860	82
200	12.1	6,930	49

180' (54.9 m) Boom length			
Radius (Feet)	Boom Angle (Degrees)	360 Degree Rating (Pounds)	From Boom Pt. to Ground (Feet)
33	80.9	125,530	185
35	80.2	115,470	184
40	78.6	95,220	184
50	75.3	69,910	181
60	72.0	54,290	178
70	68.6	43,770	175
80	65.2	36,600	170
90	61.6	30,900	165
100	57.9	26,460	160
110	54.1	22,900	153
120	50.0	19,970	145
130	45.8	17,530	136
140	41.1	15,460	126
150	36.0	13,690	113
160	30.2	12,160	98
170	23.1	10,830	78
180	12.7	9,660	47

210' (64.0 m) Boom length			
Radius (Feet)	Boom Angle (Degrees)	360 Degree Rating (Pounds)	From Boom Pt. to Ground (Feet)
38	80.8	101,470	214
40	80.3	94,180	214
50	77.5	68,880	212
60	74.7	53,200	210
70	71.8	42,650	207
80	68.9	35,540	203
90	65.9	29,830	199
100	62.9	25,370	194
110	59.8	21,800	189
120	56.6	18,870	182
130	53.3	16,430	175
140	49.8	14,360	167
150	46.1	12,580	158
160	42.2	11,040	148
170	38.0	9,690	136
180	33.3	8,510	122
190	27.9	7,460	105
200	21.4	6,530	84
210	11.8	5,710	50



**WITH 77SI OFFSET TIP BOOM AND 116,400 POUND COUNTERWEIGHT**

108,400 lb + 8,000 lb carbony counterweight

360°

**ANSI B 30.5**

220' (67.1 m) Boom length				250' (76.2 m) Boom length			
Radius (Feet)	Boom Angle (Degrees)	360 Degree Rating (Pounds)	From Boom Pt. to Ground (Feet)	Radius (Feet)	Boom Angle (Degrees)	360 Degree Rating (Pounds)	From Boom Pt. to Ground (Feet)
39	81.0	97,360	224	44	80.9	74,200 *	254
40	80.7	93,830	224	50	79.5	67,490	253
50	78.1	68,520	222	60	77.2	51,750	251
60	75.4	52,830	220	70	74.8	41,170	248
70	72.7	42,290	217	80	72.4	34,120	245
80	69.9	35,180	214	90	70.0	28,400	242
90	67.1	29,470	210	100	67.5	23,930	238
100	64.2	25,010	205	110	65.0	20,340	234
110	61.3	21,430	200	120	62.5	17,400	229
120	58.3	18,500	194	130	59.8	14,960	223
130	55.2	16,050	188	140	57.2	12,870	217
140	52.0	13,980	180	150	54.4	11,100	210
150	48.6	12,210	172	160	51.5	9,540	203
160	45.0	10,660	163	170	48.5	8,190	194
170	41.2	9,310	152	180	45.4	7,010	185
180	37.1	8,130	140	190	42.1	5,950	175
190	32.5	7,080	125	200	38.5	5,010	163
200	27.3	6,140	108	210	34.7	4,160	149
210	20.9	5,310	85	220	30.4	3,400	134
220	11.5	4,570	51	230	25.5	2,710	115

230' (70.1 m) Boom length				260' (79.2 m) Boom length			
Radius (Feet)	Boom Angle (Degrees)	360 Degree Rating (Pounds)	From Boom Pt. to Ground (Feet)	Radius (Feet)	Boom Angle (Degrees)	360 Degree Rating (Pounds)	From Boom Pt. to Ground (Feet)
41	80.8	90,190	234	46	80.8	68,160 *	264
50	78.6	68,190	233	50	79.9	67,250 *	263
60	76.0	52,490	230	60	77.7	51,870	261
70	73.4	41,940	228	70	75.4	41,280	259
80	70.8	34,850	224	80	73.1	34,250	256
90	68.2	29,130	221	90	70.8	28,520	253
100	65.4	24,670	216	100	68.4	24,050	249
110	62.7	21,090	211	110	66.0	20,460	245
120	59.8	18,170	206	120	63.6	17,510	240
130	56.9	15,710	200	130	61.1	15,060	235
140	53.9	13,640	193	140	58.6	12,980	229
150	50.7	11,870	185	150	56.0	11,200	223
160	47.4	10,320	177	160	53.3	9,640	215
170	44.0	8,970	167	170	50.5	8,290	208
180	40.2	7,780	156	180	47.5	7,100	199
190	36.2	6,730	143	190	44.5	6,050	189
200	31.7	5,790	128	200	41.2	5,100	178
210	26.6	4,950	110	210	37.7	4,250	166
220	20.4	4,200	87	220	34.0	3,490	152
230	11.3	3,540	52	230	29.8	2,800	136

240' (73.2 m) Boom length				270' (82.3 m) Boom length			
Radius (Feet)	Boom Angle (Degrees)	360 Degree Rating (Pounds)	From Boom Pt. to Ground (Feet)	Radius (Feet)	Boom Angle (Degrees)	360 Degree Rating (Pounds)	From Boom Pt. to Ground (Feet)
42	81.0	83,410 *	244	47	80.9	62,440 *	274
50	79.1	67,840	243	50	80.3	61,770 *	273
60	76.6	52,120	241	60	78.1	51,490	271
70	74.1	41,550	238	70	75.9	40,890	269
80	71.7	34,490	235	80	73.8	33,880	266
90	69.1	28,770	231	90	71.5	28,140	263
100	66.5	24,300	227	100	69.3	23,660	260
110	63.9	20,720	223	110	67.0	20,070	256
120	61.2	17,780	217	120	64.7	17,130	251
130	58.5	15,330	212	130	62.3	14,670	246
140	55.6	13,260	205	140	59.9	12,600	241
150	52.7	11,480	198	150	57.4	10,810	235
160	49.6	9,930	190	160	54.8	9,260	228
170	46.4	8,590	181	170	52.2	7,900	220
180	43.0	7,390	171	180	49.4	6,710	212
190	39.4	6,340	159	190	46.6	5,650	203
200	35.4	5,400	146	200	43.6	4,710	193
210	31.1	4,550	131	210	40.4	3,850	182
220	26.1	3,790	113	220	37.0	3,090	170
230	20.0	3,110	89				

**NOTES TO LIFTING CAPACITY**

**⚠ Warning**

This rating chart is invalid if the crane has been modified or altered by use of other than GENUINE AMERICAN PARTS as such modifications or alterations may affect its capacity or safe operation. See American Crane Corporation Service Bulliten #259.

Ratings in this chart are in POUNDS and do not exceed the percentage of tipping specified for this crane by ANSI B30.5. All ratings require that the crane be standing level on a firm uniformly supporting surface.

Do not lift loads in excess of those shown on this chart. Lifting loads in excess of those shown or operation not in accordance with good operating practice, including limitations shown on page 3499 of Operator's Manual, can cause tipping, structural damage or catastrophic failure.

Asterisk (\*) areas on this chart indicate ratings which are limited by strength of material or factors other than stability (tipping).

„RADIUS IN FEET“ is the horizontal distance at ground level from the crane centerline of rotation to a vertical line through the center of gravity of the suspended load.

When using the main boom fall with jib in place, the main fall ratings must be reduced by the jib effective weight shown on the jib rating chart plus twice the weight of all suspended blocks, slings, rope, etc., at the jib fall. See Appendix A.

When using the main boom fall with boom tip extension in place, the main fall ratings must be reduced by the weight of the boom tip extension plus twice the weight of all suspended blocks, slings, rope, etc., at the boom tip extension fall. See Appendix A.

Blocks, slings, buckets and other load carrying devices are considered part of the load. The weight of standard hoisting ropes for the rating at a given radius has been calculated as part of the boom point load and need not be considered in determining net allowable loads. See Appendix A.

This chart was developed exclusively for use with a boom only. Under no circumstances are these ratings to be interpreted for use with a jib.

Ratings shown on this chart make no allowance for such factors as out of plumb loads, wind, poor soil conditions, improper inflation of rubber tires and dynamic effects due to excessive operating speeds. The user (operator) must exercise judgement to make allowance for these conditions. See page 3499 of Operator's Manual for detailed information.

No account is taken of the wind force on the load. This effect, which can be substantial for loads with large surface areas, must be considered by the user. In any wind it is strongly recommended that taglines be used to control the load.

MAST HOIST LINE is 14 parts of 7/8 inch diameter EIPS wire rope with a minimum breaking strength of 79,600 pound.

PENDANT SUSPENSION LINE is 4 parts of 1.375 inch diameter MONOLAY wire rope with a minimum breaking strength of 208,000 pound.

MAIN LOAD LINE – 1.125 inch diameter EIPS wire rope with a minimum breaking strength of 130,000 pound.

ALTERNATE LOAD LINE (ROTATION RESISTANT) – 1.125 inch diameter BRIDON ENDURANCE DYFORM 34LR Grade 2160 wire rope with a minimum breaking strength of 167,200 pound.

**ERECTION**

Erection „OVER THE END“ is with the boom over the idler end with idler tumblers blocked (See operator's manual for blocking instructions). Erection „OVER THE SIDE“ is with the boom 90° to the sideframes and with the side frames extended. Blocks, slings and other load carrying devices must be on the ground during erection.

77SI OFFSET TIP BOOM MAXIMUM BOOM & JIB SELF-ERECTION DATA				
	OVER THE END		OVER THE SIDE	
	BOOM LENGTH (FT)	JIB LENGTH (FT)	BOOM LENGTH (FT)	JIB LENGTH (FT)
#16HL JIB	270	0	240	0
	260	0	230	60
	250	60	220	80
	240	80		

LOAD HOISTING INFORMATION - 1.125 inch diameter EIPS wire rope			
MAXIMUM LIFTING CAPACITY - LBS.	MINIMUM PARTS OF LINE	MAXIMUM HOISTING DISTANCE - FEET	
		MAIN - (FRONT)	AUX. - (REAR)
235,130	7	187	187
222,840	6	218	218
185,700	5	262	262
148,560	4	328	328
111,420	3	437	437
74,280	2	656	656
37,140	1	1,312	1,312

LOAD HOISTING INFORMATION (ROTATION RESISTANT LOAD LINE) 1.125 inch diameter BRIDON ENDURANCE DYFORM 34LR Grade 2160 wire rope			
MAXIMUM LIFTING CAPACITY - LBS.	MINIMUM PARTS OF LINE	MAXIMUM HOISTING DISTANCE - FEET	
		MAIN - (FRONT)	AUX. - (REAR)
234,080	7	187	187
200,640	6	218	218
167,200	5	262	262
133,760	4	328	328
100,320	3	437	437
66,880	2	656	656
33,440	1	1,312	1,312

Note: The Single Sheave Boom Point Extension is required to reeve 7 parts of line. The weight of the Single Sheave Boom Point Extension is 590 Pounds.

77SI OFFSET TIP BOOM COMPOSITION CHART							
BOOM LENGTH (METERS)	BOOM LENGTH (FEET)	BOOM SECTIONS					
		9.1 M 30' 77SI INNER	3.0 M 10' 77S CENTER	6.1 M 20' 77S CENTER	15.2 M 50' 77S CENTER	5.9 M 19.5' 77HL OUTER	9.1 M 30' 77LA OFFSET TIP
24.4 M	80	1	0	0	0	1	1
27.4 M	90	1	0	0	0	1	1
30.5 M	100	1	0	1	0	1	1
33.5 M	110	1	1	1	0	1	1
36.6 M	120	1	0	2	0	1	1
39.6 M	130	1	0	0	1	1	1
42.7 M	140	1	1	0	1	1	1
45.7 M	150	1	0	1	1	1	1
48.8 M	160	1	1	1	1	1	1
51.8 M	170	1	0	2	1	1	1
54.9 M	180	1	0	0	2	1	1
57.9 M	190	1	1	0	2	1	1
61.0 M	200	1	0	1	2	1	1
64.0 M	210	1	1	1	2	1	1
67.1 M	220	1	0	2	2	1	1
70.1 M	230	1	0	0	3	1	1
73.2 M	240	1	1	0	3	1	1
76.2 M	250	1	0	1	3	1	1
79.2 M	260	1	1	1	3	1	1
82.3 M	270	1	0	2	3	1	1

**RANGE DIAGRAM, 77SI HAMMERHEAD TIP BOOM, #16HL JIB**

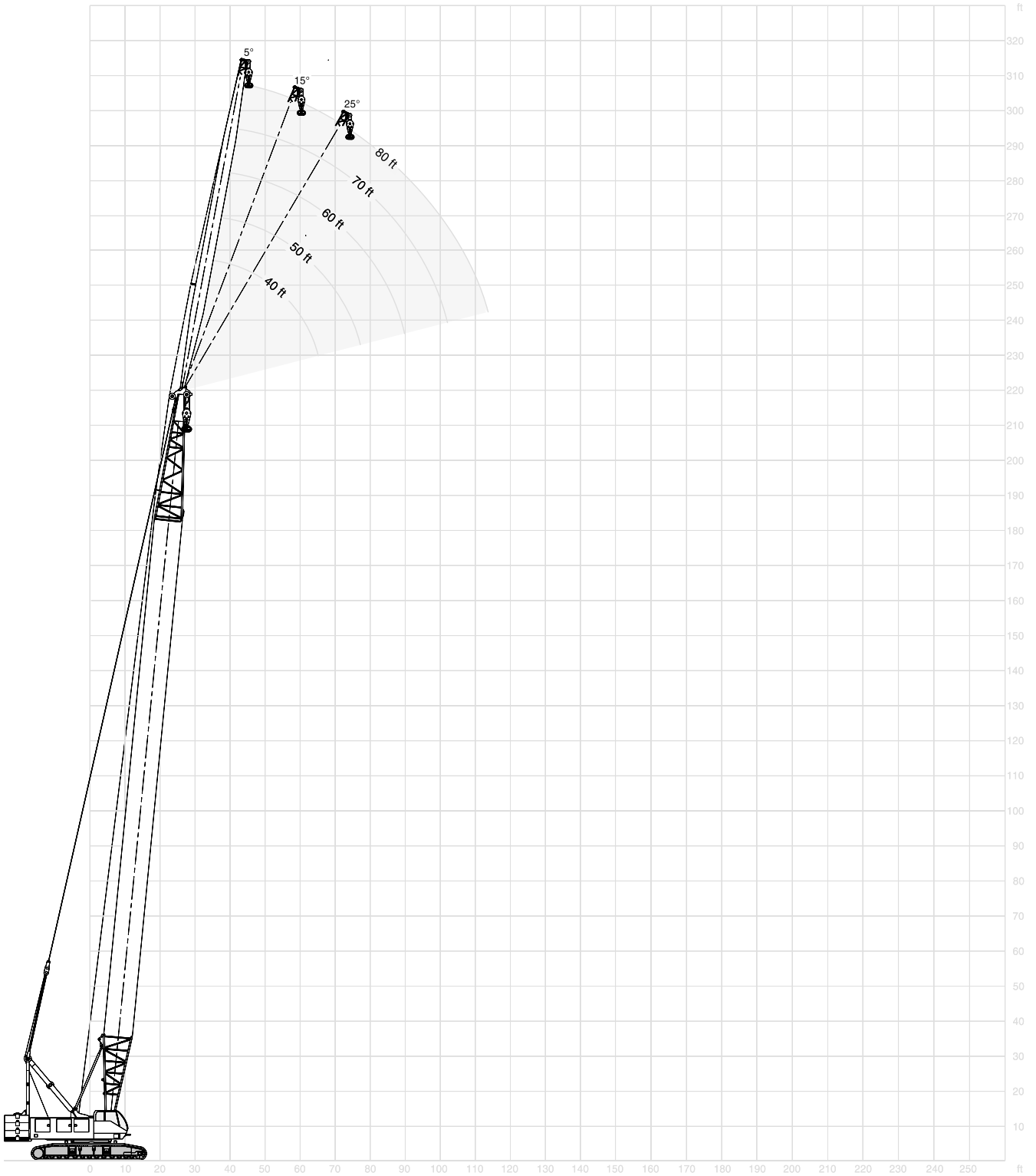

**WITH 77SI HAMMERHEAD TIP BOOM AND 102,000 POUND UPPER COUNTERWEIGHT #16HL JIB**

102,000 lb 360° ANSI B 30.5

**40' (12.2 m) Jib length**

Boom length	Jib Radius (Feet)	5.0 Deg offset		15.0 Deg offset		25.0 Deg offset	
		Boom Angle	Rating (Pounds)	Boom Angle	Rating (Pounds)	Boom Angle	Rating (Pounds)
	26	82.8	32,000*	-	-	-	-
	30	81.2	32,000*	-	-	-	-
	35	79.1	32,000*	81.8	32,000*	-	-
	40	77.0	32,000*	79.7	32,000*	82.3	32,000*
<b>100' (30.5 m)</b>	50	72.8	32,000*	75.5	32,000*	78.0	31,870*
	60	68.5	32,000*	71.2	32,000*	73.6	28,630*
	70	64.1	32,000*	66.7	31,970*	69.1	25,980*
	80	59.4	32,000*	62.0	28,980*	64.3	23,890*
	90	54.6	30,460	57.1	26,510*	59.3	22,270*
	100	49.3	26,280	51.8	24,550*	53.9	20,840*

	27	82.9	32,000*	-	-	-	-
	30	81.7	32,000*	-	-	-	-
	35	79.8	32,000*	82.4	32,000*	-	-
	40	77.9	32,000*	80.4	32,000*	82.8	32,000*
<b>110' (33.5 m)</b>	50	74.0	32,000*	76.5	32,000*	78.9	32,000*
	60	70.0	32,000*	72.5	32,000*	74.8	29,370*
	70	65.9	32,000*	68.4	32,000*	70.6	26,830*
	80	61.7	32,000*	64.1	30,190*	66.3	24,630*
	90	57.2	30,010	59.6	27,680*	61.7	22,970*
	100	52.6	25,830	54.9	25,620*	56.9	21,490*
	110	47.5	22,480	49.8	22,490	51.7	20,330*

	28	83.0	32,000*	-	-	-	-
	30	82.3	32,000*	-	-	-	-
	35	80.5	32,000*	82.8	32,000*	-	-
	40	78.7	32,000*	81.0	32,000*	-	-
<b>120' (36.6 m)</b>	50	75.0	32,000*	77.4	32,000*	79.6	32,000*
	60	71.3	32,000*	73.6	32,000*	75.8	30,060*
	70	67.5	32,000*	69.8	32,000*	71.9	27,510*
	80	63.6	32,000*	65.9	31,210*	67.9	25,410*
	90	59.5	29,580	61.8	28,740*	63.8	23,590*
	100	55.3	25,390	57.5	25,400	59.4	22,190*
	110	50.8	22,050	52.9	22,060	54.8	20,950*
	120	45.9	19,300	48.1	19,310	49.8	19,320

	30	82.7	32,000*	-	-	-	-
	35	81.0	32,000*	-	-	-	-
	40	79.3	32,000*	81.6	32,000*	-	-
	50	75.9	32,000*	78.1	32,000*	80.2	32,000*
<b>130' (39.6 m)</b>	60	72.4	32,000*	74.6	32,000*	76.7	30,720*
	70	68.9	32,000*	71.1	32,000*	73.1	28,150*
	80	65.2	32,000*	67.4	32,000*	69.3	26,040*
	90	61.5	29,140	63.6	29,140	65.5	24,230*
	100	57.6	24,950	59.7	24,950	61.5	22,810*
	110	53.5	21,590	55.5	21,600	57.3	21,540*
	120	49.1	18,850	51.2	18,860	52.8	18,870
	130	44.5	16,580	46.5	16,580	48.0	16,590

Boom length	Jib Radius (Feet)	5.0 Deg offset		15.0 Deg offset		25.0 Deg offset	
		Boom Angle	Rating (Pounds)	Boom Angle	Rating (Pounds)	Boom Angle	Rating (Pounds)
	31	82.8	32,000*	-	-	-	-
	35	81.5	32,000*	-	-	-	-
	40	79.9	32,000*	82.0	32,000*	-	-
	50	76.7	32,000*	78.8	32,000*	80.8	32,000*
	60	73.4	32,000*	75.5	32,000*	77.4	31,230*
	70	70.1	32,000*	72.2	32,000*	74.1	28,760*
<b>140' (42.7 m)</b>	80	66.7	32,000*	68.7	32,000*	70.6	26,630*
	90	63.2	28,700	65.2	28,710	67.0	24,870*
	100	59.6	24,510	61.6	24,520	63.3	23,370*
	110	55.8	21,150	57.8	21,160	59.5	21,170
	120	51.8	18,410	53.8	18,410	55.4	18,430
	130	47.7	16,120	49.6	16,130	51.1	16,140
	140	43.2	14,200	45.0	14,200	46.5	14,220

	32	82.9	32,000*	-	-	-	-
	35	82.0	32,000*	-	-	-	-
	40	80.5	32,000*	82.5	32,000*	-	-
	50	77.4	32,000*	79.4	32,000*	81.3	32,000*
	60	74.3	32,000*	76.3	32,000*	78.1	31,780*
	70	71.2	32,000*	73.1	32,000*	74.9	29,350*
<b>150' (45.7 m)</b>	80	68.0	32,000*	69.9	32,000*	71.7	27,250*
	90	64.7	28,310	66.6	28,320	68.3	25,450*
	100	61.3	24,120	63.2	24,120	64.9	23,970*
	110	57.8	20,760	59.7	20,760	61.3	20,770
	120	54.2	18,010	56.0	18,010	57.6	18,030
	130	50.4	15,730	52.2	15,730	53.7	15,740
	140	46.3	13,790	48.1	13,800	49.5	13,810
	150	41.9	12,140	43.7	12,150	45.0	12,160

	33	82.9	32,000*	-	-	-	-
	35	82.4	32,000*	-	-	-	-
	40	80.9	32,000*	82.8	32,000*	-	-
	50	78.0	32,000*	79.9	32,000*	81.7	32,000*
	60	75.1	32,000*	77.0	32,000*	78.8	32,000*
	70	72.1	32,000*	74.0	32,000*	75.7	29,780*
<b>160' (48.8 m)</b>	80	69.1	32,000*	71.0	32,000*	72.7	27,800*
	90	66.0	27,870	67.9	27,880	69.5	26,000*
	100	62.9	23,670	64.7	23,680	66.3	23,690
	110	59.6	20,310	61.4	20,320	63.0	20,330
	120	56.2	17,560	58.0	17,570	59.5	17,580
	130	52.7	15,280	54.4	15,280	55.9	15,290
	140	49.0	13,340	50.7	13,340	52.1	13,350
	150	45.1	11,690	46.7	11,700	48.1	11,710
	160	40.8	10,260	42.4	10,270	43.7	10,280



**WITH 77SI HAMMERHEAD TIP BOOM AND 102,000 POUND UPPER COUNTERWEIGHT  
#16HL JIB**

102,000 lb

360°

ANSI B 30.5

**40' (12.2 m) Jib length**

Boom length	Jib Radius (Feet)	5.0 Deg offset		15.0 Deg offset		25.0 Deg offset	
		Boom Angle	Rating (Pounds)	Boom Angle	Rating (Pounds)	Boom Angle	Rating (Pounds)
	34	83.0	32,000*	-	-	-	-
	35	82.7	32,000*	-	-	-	-
	40	81.4	32,000*	-	-	-	-
	50	78.6	32,000*	80.4	32,000*	82.1	32,000*
	60	75.8	32,000*	77.6	32,000*	79.3	32,000*
	70	73.0	32,000*	74.8	32,000*	76.4	30,390*
<b>170'</b> <b>(51.8 m)</b>	80	70.2	32,000*	71.9	32,000*	73.5	28,310*
	90	67.2	27,440	69.0	27,440	70.6	26,500*
	100	64.3	23,240	66.0	23,250	67.5	23,260
	110	61.2	19,880	62.9	19,880	64.4	19,890
	120	58.0	17,120	59.7	17,130	61.2	17,140
	130	54.8	14,840	56.4	14,840	57.9	14,850
	140	51.3	12,890	53.0	12,900	54.4	12,910
	150	47.7	11,230	49.3	11,240	50.7	11,250
	160	43.9	9,810	45.5	9,820	46.7	9,830
	170	39.8	8,570	41.3	8,570	42.5	8,590

	36	82.8	32,000*	-	-	-	-
	40	81.8	32,000*	-	-	-	-
	50	79.1	32,000*	80.9	32,000*	82.5	32,000*
	60	76.5	32,000*	78.2	32,000*	79.8	32,000*
	70	73.8	32,000*	75.5	32,000*	77.1	30,810*
	80	71.1	32,000*	72.8	32,000*	74.3	28,800*
<b>180'</b> <b>(54.9 m)</b>	90	68.3	27,010	70.0	27,010	71.5	27,010*
	100	65.5	22,800	67.2	22,800	68.7	22,810
	110	62.6	19,430	64.3	19,440	65.7	19,450
	120	59.6	16,680	61.3	16,680	62.7	16,700
	130	56.6	14,380	58.2	14,390	59.6	14,400
	140	53.4	12,440	55.0	12,450	56.3	12,460
	150	50.1	10,780	51.6	10,790	52.9	10,800
	160	46.6	9,340	48.1	9,350	49.3	9,360
	170	42.8	8,100	44.3	8,110	45.5	8,120
	180	38.8	7,010	40.3	7,020	41.3	7,030

	37	82.9	32,000*	-	-	-	-
	40	82.1	32,000*	-	-	-	-
	50	79.6	32,000*	81.3	32,000*	82.8	32,000*
	60	77.1	32,000*	78.7	32,000*	80.3	32,000*
	70	74.5	32,000*	76.2	32,000*	77.7	31,190*
	80	71.9	31,970	73.6	31,980	75.0	29,180*
	90	69.3	26,570	70.9	26,570	72.4	26,580
	100	66.6	22,370	68.2	22,370	69.7	22,380
<b>190'</b> <b>(57.9 m)</b>	110	63.9	19,000	65.5	19,000	66.9	19,020
	120	61.1	16,240	62.7	16,240	64.0	16,250
	130	58.2	13,940	59.8	13,950	61.1	13,960
	140	55.2	12,000	56.8	12,000	58.1	12,010
	150	52.1	10,330	53.6	10,340	54.9	10,350
	160	48.9	8,900	50.4	8,910	51.6	8,920
	170	45.5	7,650	46.9	7,650	48.1	7,670
	180	41.8	6,560	43.3	6,560	44.3	6,580
	190	37.9	5,590	39.3	5,600	40.3	5,620

Boom length	Jib Radius (Feet)	5.0 Deg offset		15.0 Deg offset		25.0 Deg offset	
		Boom Angle	Rating (Pounds)	Boom Angle	Rating (Pounds)	Boom Angle	Rating (Pounds)
	38	82.9	32,000*	-	-	-	-
	40	82.4	32,000*	-	-	-	-
	50	80.0	32,000*	81.6	32,000*	-	-
	60	77.6	32,000*	79.2	32,000*	80.7	32,000*
	70	75.2	32,000*	76.7	32,000*	78.2	31,590*
	80	72.7	31,570	74.3	31,580	75.7	29,630*
	90	70.2	26,180	71.7	26,180	73.2	26,190
	100	67.7	21,970	69.2	21,970	70.6	21,980
<b>200'</b> <b>(61.0 m)</b>	110	65.1	18,600	66.6	18,600	67.9	18,610
	120	62.4	15,830	63.9	15,840	65.2	15,850
	130	59.7	13,530	61.2	13,530	62.5	13,540
	140	56.9	11,590	58.3	11,590	59.6	11,610
	150	54.0	9,920	55.4	9,930	56.6	9,940
	160	50.9	8,490	52.4	8,490	53.6	8,510
	170	47.8	7,240	49.2	7,250	50.3	7,260
	180	44.5	6,140	45.8	6,140	46.9	6,160
	190	40.9	5,170	42.3	5,180	43.3	5,190
	200	37.1	4,310	38.4	4,320	39.3	4,330

	39	83.0	32,000*	-	-	-	-
	40	82.7	32,000*	-	-	-	-
	50	80.4	32,000*	82.0	32,000*	-	-
	60	78.1	32,000*	79.6	32,000*	81.1	32,000*
	70	75.8	32,000*	77.3	32,000*	78.7	31,970*
	80	73.4	31,140	74.9	31,150	76.3	30,080*
	90	71.0	25,740	72.5	25,740	73.9	25,750
	100	68.6	21,530	70.1	21,530	71.4	21,540
<b>210'</b> <b>(64.0 m)</b>	110	66.1	18,160	67.6	18,160	68.9	18,170
	120	63.6	15,390	65.0	15,390	66.3	15,400
	130	61.0	13,080	62.4	13,090	63.7	13,100
	140	58.4	11,140	59.8	11,150	61.0	11,160
	150	55.6	9,470	57.0	9,480	58.2	9,490
	160	52.8	8,040	54.2	8,040	55.3	8,060
	170	49.8	6,780	51.2	6,780	52.3	6,800
	180	46.8	5,680	48.1	5,690	49.2	5,700
	190	43.5	4,710	44.8	4,720	45.8	4,730
	200	40.0	3,840	41.3	3,850	42.3	3,860
	210	36.3	3,070	37.5	3,080	38.4	3,100

	41	82.8	32,000*	-	-	-	-
	50	80.8	32,000*	82.3	32,000*	-	-
	60	78.6	32,000*	80.0	32,000*	81.4	32,000*
	70	76.3	32,000*	77.8	32,000*	79.1	32,000*
	80	74.1	30,720	75.5	30,730	76.8	30,360*
	90	71.8	25,320	73.2	25,320	74.5	25,330
	100	69.4	21,090	70.9	21,100	72.2	21,110
	110	67.1	17,720	68.5	17,730	69.8	17,740
<b>220'</b> <b>(67.1 m)</b>	120	64.7	14,960	66.1	14,960	67.3	14,970
	130	62.2	12,650	63.6	12,660	64.8	12,670
	140	59.7	10,700	61.1	10,700	62.3	10,710
	150	57.1	9,040	58.5	9,040	59.6	9,050
	160	54.4	7,590	55.8	7,600	56.9	7,610
	170	51.7	6,340	53.0	6,340	54.1	6,350
	180	48.8	5,230	50.1	5,230	51.2	5,250
	190	45.8	4,250	47.1	4,260	48.1	4,270
	200	42.6	3,390	43.9	3,400	44.8	3,410
	210	39.2	2,620	40.5	2,620	41.3	2,640

**WITH 77SI HAMMERHEAD TIP BOOM AND 102,000 POUND UPPER COUNTERWEIGHT  
#16HL JIB**

102,000 lb 360° ANSI B 30.5

**50' (15.2 m) Jib length**

Boom length	Jib Radius (Feet)	5.0 Deg offset		15.0 Deg offset		25.0 Deg offset	
		Boom Angle	Rating (Pounds)	Boom Angle	Rating (Pounds)	Boom Angle	Rating (Pounds)
	32	82.7	32,000*	-	-	-	-
	35	81.8	32,000*	-	-	-	-
	40	80.2	32,000*	82.8	29,160*	-	-
	50	77.0	30,720*	79.6	28,290*	82.1	26,260*
<b>130' (39.6 m)</b>	60	73.7	29,600*	76.3	27,380*	78.8	25,740*
	70	70.4	28,580*	73.0	26,640*	75.4	23,910*
	80	67.0	27,750*	69.5	25,930*	71.9	22,110*
	90	63.5	26,890*	66.0	25,320*	68.3	20,640*
	100	59.8	25,230	62.3	23,620*	64.6	19,330*
	110	56.1	21,880	58.5	21,890	60.7	18,220*
	120	52.1	19,140	54.6	19,140	56.7	17,280*
	130	47.9	16,850	50.3	16,860	52.3	16,470*

	33	82.8	32,000*	-	-	-	-
	35	82.2	32,000*	-	-	-	-
	40	80.7	32,000*	-	-	-	-
	50	77.7	30,910*	80.2	28,390*	82.5	26,350*
	60	74.6	29,810*	77.1	27,490*	79.4	25,740*
	70	71.4	28,910*	73.9	26,760*	76.2	24,390*
<b>140' (42.7 m)</b>	80	68.2	27,980*	70.7	26,070*	72.9	22,570*
	90	65.0	27,100*	67.4	25,520*	69.6	21,030*
	100	61.6	24,790	64.0	24,430*	66.1	19,800*
	110	58.1	21,440	60.4	21,440	62.5	18,650*
	120	54.4	18,690	56.8	18,700	58.8	17,680*
	130	50.6	16,400	52.9	16,400	54.9	16,420
	140	46.6	14,470	48.8	14,480	50.7	14,490

	34	82.9	32,000*	-	-	-	-
	35	82.6	32,000*	-	-	-	-
	40	81.2	32,000*	-	-	-	-
	50	78.3	31,040*	80.7	28,390*	82.9	26,300*
	60	75.4	30,100*	77.7	27,650*	79.9	25,720*
	70	72.4	29,120*	74.7	26,880*	76.9	24,760*
<b>150' (45.7 m)</b>	80	69.4	28,170*	71.7	26,230*	73.8	23,020*
	90	66.3	27,360*	68.6	25,670*	70.7	21,480*
	100	63.1	24,390	65.4	24,400	67.5	20,170*
	110	59.9	21,030	62.1	21,040	64.1	19,080*
	120	56.5	18,280	58.7	18,290	60.7	18,110*
	130	52.9	16,000	55.1	16,000	57.0	16,020
	140	49.2	14,060	51.4	14,060	53.2	14,080
	150	45.3	12,410	47.4	12,420	49.1	12,430

	35	83.0	32,000*	-	-	-	-
	40	81.6	32,000*	-	-	-	-
	50	78.8	31,280*	81.1	28,400*	-	-
	60	76.1	30,170*	78.3	27,660*	80.4	25,790*
	70	73.3	29,310*	75.5	26,990*	77.6	25,220*
	80	70.4	28,440*	72.6	26,390*	74.7	23,380*
<b>160' (48.8 m)</b>	90	67.5	27,570*	69.7	25,780*	71.7	21,890*
	100	64.5	23,950	66.7	23,960	68.6	20,590*
	110	61.4	20,590	63.6	20,590	65.5	19,440*
	120	58.3	17,830	60.4	17,840	62.3	17,850
	130	55.0	15,540	57.1	15,540	58.9	15,560
	140	51.6	13,600	53.6	13,610	55.4	13,620
	150	48.0	11,940	50.0	11,950	51.7	11,970
	160	44.1	10,520	46.1	10,530	47.7	10,550

Boom length	Jib Radius (Feet)	5.0 Deg offset		15.0 Deg offset		25.0 Deg offset	
		Boom Angle	Rating (Pounds)	Boom Angle	Rating (Pounds)	Boom Angle	Rating (Pounds)
	37	82.8	32,000*	-	-	-	-
	40	82.0	32,000*	-	-	-	-
	50	79.4	31,260*	81.5	28,440*	-	-
	60	76.7	30,360*	78.9	27,790*	80.9	25,790*
	70	74.0	29,380*	76.2	27,100*	78.2	25,270*
	80	71.3	28,590*	73.4	26,460*	75.4	23,790*
<b>170' (51.8 m)</b>	90	68.5	27,710	70.7	25,870*	72.6	22,270*
	100	65.7	23,510	67.8	23,510	69.7	20,980*
	110	62.8	20,140	64.9	20,150	66.8	19,840*
	120	59.9	17,390	61.9	17,400	63.7	17,410
	130	56.8	15,100	58.8	15,110	60.6	15,120
	140	53.6	13,150	55.6	13,160	57.3	13,170
	150	50.3	11,500	52.3	11,510	53.9	11,520
	160	46.8	10,070	48.7	10,070	50.3	10,090
	170	43.1	8,820	44.9	8,830	46.4	8,850

	38	82.8	32,000*	-	-	-	-
	40	82.3	32,000*	-	-	-	-
	50	79.8	31,420*	81.9	28,480*	-	-
	60	77.3	30,430*	79.4	27,790*	81.3	25,770*
	70	74.7	29,570*	76.8	27,210*	78.7	25,320*
	80	72.2	28,720*	74.2	26,530*	76.1	24,160*
<b>180' (54.9 m)</b>	90	69.5	27,270	71.5	25,960*	73.4	22,620*
	100	66.8	23,070	68.8	23,070	70.7	21,350*
	110	64.1	19,700	66.1	19,710	67.9	19,720
	120	61.3	16,940	63.3	16,940	65.0	16,950
	130	58.4	14,640	60.4	14,650	62.1	14,660
	140	55.4	12,710	57.4	12,710	59.0	12,730
	150	52.3	11,040	54.2	11,050	55.8	11,060
	160	49.1	9,610	51.0	9,620	52.5	9,630
	170	45.7	8,360	47.5	8,360	49.0	8,380
	180	42.1	7,270	43.8	7,270	45.2	7,290

	39	82.9	32,000*	-	-	-	-
	40	82.6	32,000*	-	-	-	-
	50	80.2	31,420*	82.2	28,450*	-	-
	60	77.8	30,490*	79.8	27,820*	81.7	25,700*
	70	75.4	29,730*	77.4	27,200*	79.2	25,270*
	80	72.9	28,960*	74.9	26,580*	76.7	24,420*
	90	70.4	26,840	72.3	26,140*	74.1	22,960*
	100	67.9	22,630	69.8	22,630	71.5	21,700*
<b>190' (57.9 m)</b>	110	65.3	19,260	67.2	19,260	68.9	19,280
	120	62.6	16,500	64.5	16,510	66.2	16,520
	130	59.9	14,200	61.8	14,210	63.4	14,220
	140	57.1	12,260	58.9	12,270	60.5	12,280
	150	54.2	10,590	56.0	10,600	57.6	10,610
	160	51.1	9,160	53.0	9,170	54.5	9,180
	170	48.0	7,900	49.8	7,910	51.2	7,920
	180	44.7	6,810	46.4	6,810	47.8	6,830
	190	41.1	5,840	42.8	5,850	44.1	5,870



**WITH 77SI HAMMERHEAD TIP BOOM AND 102,000 POUND UPPER COUNTERWEIGHT #16HL JIB**

102,000 lb

360°

ANSI B 30.5

**50' (15.2 m) Jib length**

Boom length	Jib Radius (Feet)	5.0 Deg offset		15.0 Deg offset		25.0 Deg offset	
		Boom Angle	Rating (Pounds)	Boom Angle	Rating (Pounds)	Boom Angle	Rating (Pounds)
	40	82.9	32,000*	-	-	-	-
	50	80.6	31,490*	82.6	28,430*	-	-
	60	78.3	30,650*	80.2	27,740*	82.0	25,590*
	70	76.0	29,740*	77.9	27,200*	79.6	25,280*
	80	73.6	28,970*	75.5	26,660*	77.2	24,770*
	90	71.2	26,440	73.1	26,110*	74.8	23,300*
	100	68.8	22,230	70.6	22,230	72.3	22,030*
	110	66.3	18,850	68.1	18,850	69.8	18,860
200' (61.0 m)	120	63.8	16,090	65.6	16,100	67.2	16,110
	130	61.2	13,780	63.0	13,790	64.6	13,800
	140	58.5	11,840	60.3	11,850	61.9	11,860
	150	55.8	10,170	57.6	10,180	59.1	10,190
	160	53.0	8,740	54.7	8,750	56.2	8,760
	170	50.0	7,490	51.8	7,490	53.2	7,510
	180	47.0	6,380	48.7	6,390	50.0	6,400
	190	43.7	5,410	45.4	5,420	46.7	5,430
200	40.2	4,550	41.9	4,560	43.1	4,580	

Boom length	Jib Radius (Feet)	5.0 Deg offset		15.0 Deg offset		25.0 Deg offset	
		Boom Angle	Rating (Pounds)	Boom Angle	Rating (Pounds)	Boom Angle	Rating (Pounds)
	43	82.8	31,940*	-	-	-	-
	50	81.3	31,460*	-	-	-	-
	60	79.2	30,670*	81.0	27,710*	82.6	25,550*
	70	77.0	29,960*	78.8	27,210*	80.4	25,190*
	80	74.9	29,130*	76.6	26,670*	78.2	24,850*
	90	72.7	25,570	74.4	25,570	76.0	23,920*
	100	70.4	21,360	72.1	21,360	73.7	21,370
	110	68.2	17,970	69.9	17,980	71.4	17,990
220' (67.1 m)	120	65.9	15,200	67.6	15,210	69.1	15,220
	130	63.5	12,900	65.2	12,900	66.7	12,920
	140	61.1	10,950	62.8	10,960	64.3	10,970
	150	58.7	9,280	60.3	9,290	61.8	9,300
	160	56.1	7,840	57.8	7,850	59.2	7,860
	170	53.5	6,580	55.1	6,580	56.5	6,600
	180	50.8	5,470	52.4	5,480	53.8	5,500
	190	48.0	4,500	49.6	4,500	50.9	4,520
	200	45.1	3,630	46.6	3,640	47.8	3,660
	210	42.0	2,850	43.5	2,860	44.6	2,880
220	38.6	2,160	40.1	2,170	41.2	2,190	

	41	83.0	32,000*	-	-	-	-
	50	81.0	31,500*	82.8	28,400*	-	-
	60	78.8	30,600*	80.6	27,790*	82.3	25,550*
	70	76.5	29,840*	78.3	27,210*	80.1	25,240*
	80	74.3	29,130*	76.1	26,700*	77.8	24,840*
	90	72.0	26,000	73.8	26,000	75.4	23,620*
	100	69.6	21,790	71.4	21,790	73.1	21,800
	110	67.3	18,400	69.0	18,410	70.7	18,420
210' (64.0 m)	120	64.9	15,650	66.6	15,650	68.2	15,670
	130	62.4	13,340	64.1	13,350	65.7	13,360
	140	59.9	11,400	61.6	11,400	63.1	11,420
	150	57.3	9,730	59.0	9,730	60.5	9,750
	160	54.6	8,280	56.3	8,290	57.8	8,300
	170	51.9	7,030	53.5	7,030	54.9	7,050
	180	49.0	5,930	50.6	5,930	52.0	5,950
	190	46.0	4,950	47.6	4,960	48.9	4,970
200	42.8	4,080	44.4	4,090	45.6	4,110	
210	39.4	3,320	41.0	3,320	42.1	3,340	

**60' (18.3 m) Jib length**

Boom length	Jib Radius (Feet)	5.0 Deg offset		15.0 Deg offset		25.0 Deg offset	
		Boom Angle	Rating (Pounds)	Boom Angle	Rating (Pounds)	Boom Angle	Rating (Pounds)
	36	82.9	29,770*	-	-	-	-
	40	81.8	29,310*	-	-	-	-
	50	79.1	28,220*	81.8	25,520*	-	-
	60	76.3	27,180*	79.0	24,720*	81.6	22,840*
	70	73.5	26,280*	76.2	24,030*	78.7	21,700*
	80	70.6	25,330*	73.3	23,420*	75.8	20,160*
150' (45.7 m)	90	67.7	24,620*	70.4	22,760*	72.8	18,790*
	100	64.7	23,870*	67.4	21,930*	69.8	17,610*
	110	61.7	21,280	64.3	20,460*	66.6	16,620*
	120	58.5	18,520	61.1	18,530	63.4	15,760*
	130	55.2	16,240	57.8	16,240	60.0	14,980*
	140	51.8	14,300	54.3	14,310	56.5	14,320*
	150	48.2	12,650	50.7	12,650	52.8	12,670

Boom length	Jib Radius (Feet)	5.0 Deg offset		15.0 Deg offset		25.0 Deg offset	
		Boom Angle	Rating (Pounds)	Boom Angle	Rating (Pounds)	Boom Angle	Rating (Pounds)
	37	83.0	29,690*	-	-	-	-
	40	82.2	29,360*	-	-	-	-
	50	79.6	28,350*	82.2	25,540*	-	-
	60	76.9	27,370*	79.5	24,810*	82.0	22,840*
	70	74.3	26,400*	76.8	24,090*	79.3	21,990*
	80	71.5	25,570*	74.1	23,480*	76.5	20,460*
160' (48.8 m)	90	68.8	24,750*	71.3	22,950*	73.7	19,100*
	100	65.9	24,040*	68.5	22,400*	70.8	17,910*
	110	63.1	20,830	65.6	20,840	67.8	16,930*
	120	60.1	18,080	62.6	18,090	64.8	16,090*
	130	57.0	15,780	59.5	15,790	61.6	15,330*
	140	53.8	13,840	56.3	13,850	58.4	13,870
	150	50.5	12,190	52.9	12,200	54.9	12,220
	160	47.0	10,760	49.3	10,760	51.3	10,780

**WITH 77SI HAMMERHEAD TIP BOOM AND 102,000 POUND UPPER COUNTERWEIGHT  
#16HL JIB**

102,000 lb 360° ANSI B 30.5

**60' (18.3 m) Jib length**

Boom length	Jib Radius (Feet)	5.0 Deg offset		15.0 Deg offset		25.0 Deg offset	
		Boom Angle	Rating (Pounds)	Boom Angle	Rating (Pounds)	Boom Angle	Rating (Pounds)
	39	82.8	29,570*	-	-	-	-
	40	82.5	29,440*	-	-	-	-
	50	80.0	28,370*	82.5	25,520*	-	-
	60	77.5	27,510*	80.0	24,800*	82.3	22,770*
	70	75.0	26,630*	77.4	24,150*	79.7	22,200*
	80	72.4	25,710*	74.8	23,540*	77.1	20,670*
<b>170' (51.8 m)</b>	90	69.7	24,980*	72.2	22,990*	74.4	19,390*
	100	67.1	23,760	69.5	22,480*	71.7	18,230*
	110	64.3	20,390	66.7	20,400	68.9	17,210*
	120	61.5	17,640	63.9	17,640	66.0	16,350*
	130	58.6	15,340	61.0	15,350	63.1	15,370
	140	55.6	13,400	58.0	13,400	60.0	13,420
	150	52.5	11,740	54.8	11,750	56.8	11,770
	160	49.3	10,310	51.6	10,320	53.5	10,340
	170	45.9	9,060	48.1	9,060	50.0	9,080

	40	82.8	29,400*	-	-	-	-
	50	80.5	28,510*	82.8	25,470*	-	-
	60	78.0	27,520*	80.4	24,890*	82.7	22,790*
	70	75.6	26,740*	78.0	24,220*	80.2	22,280*
	80	73.1	25,920*	75.5	23,700*	77.7	20,960*
	90	70.6	25,170*	72.9	23,130*	75.1	19,690*
<b>180' (54.9 m)</b>	100	68.1	23,320	70.4	22,540*	72.5	18,490*
	110	65.5	19,940	67.8	19,940	69.9	17,500*
	120	62.8	17,180	65.1	17,190	67.1	16,630*
	130	60.1	14,890	62.3	14,900	64.4	14,910
	140	57.3	12,940	59.5	12,950	61.5	12,960
	150	54.4	11,280	56.6	11,290	58.5	11,310
	160	51.4	9,850	53.5	9,860	55.4	9,870
	170	48.2	8,590	50.3	8,600	52.1	8,620
	180	44.9	7,500	47.0	7,510	48.7	7,520

	41	82.9	29,230*	-	-	-	-
	50	80.8	28,450*	-	-	-	-
	60	78.5	27,650*	80.8	24,810*	83.0	22,650*
	70	76.2	26,850*	78.5	24,290*	80.6	22,320*
	80	73.8	25,990*	76.1	23,760*	78.2	21,170*
	90	71.4	25,250*	73.7	23,180*	75.7	19,950*
<b>190' (57.9 m)</b>	100	69.0	22,880	71.2	22,690*	73.3	18,810*
	110	66.5	19,500	68.7	19,500	70.7	17,800*
	120	64.0	16,740	66.2	16,750	68.2	16,760
	130	61.4	14,430	63.6	14,440	65.5	14,460
	140	58.7	12,490	60.9	12,500	62.8	12,520
	150	56.0	10,830	58.1	10,840	60.0	10,860
	160	53.2	9,390	55.3	9,400	57.1	9,410
	170	50.2	8,140	52.3	8,150	54.1	8,160
	180	47.1	7,040	49.2	7,050	50.9	7,070
	190	43.9	6,070	45.9	6,080	47.5	6,100

Boom length	Jib Radius (Feet)	5.0 Deg offset		15.0 Deg offset		25.0 Deg offset	
		Boom Angle	Rating (Pounds)	Boom Angle	Rating (Pounds)	Boom Angle	Rating (Pounds)
	42	83.0	29,210*	-	-	-	-
	50	81.2	28,530*	-	-	-	-
	60	79.0	27,680*	81.2	24,820*	-	-
	70	76.7	26,860*	78.9	24,260*	81.0	22,250*
	80	74.4	26,170*	76.6	23,730*	78.7	21,470*
	90	72.2	25,450*	74.3	23,220*	76.3	20,170*
	100	69.8	22,470	72.0	22,470	74.0	19,000*
	110	67.5	19,090	69.6	19,100	71.5	18,040*
<b>200' (61.0 m)</b>	120	65.1	16,330	67.2	16,330	69.1	16,350
	130	62.6	14,030	64.7	14,040	66.6	14,050
	140	60.1	12,080	62.2	12,090	64.0	12,100
	150	57.5	10,420	59.6	10,430	61.4	10,440
	160	54.8	8,970	56.9	8,980	58.6	8,990
	170	52.1	7,720	54.1	7,720	55.8	7,740
	180	49.2	6,620	51.2	6,630	52.8	6,640
	190	46.2	5,640	48.1	5,650	49.7	5,670
	200	43.0	4,780	44.9	4,790	46.4	4,810

	44	82.8	28,990*	-	-	-	-
	50	81.5	28,480*	-	-	-	-
	60	79.4	27,700*	81.5	24,760*	-	-
	70	77.2	26,960*	79.3	24,260*	81.3	22,190*
	80	75.0	26,210*	77.1	23,790*	79.1	21,680*
	90	72.8	25,510*	74.9	23,240*	76.9	20,390*
	100	70.6	22,030	72.7	22,030	74.6	19,300*
	110	68.3	18,640	70.4	18,650	72.3	18,320*
<b>210' (64.0 m)</b>	120	66.0	15,880	68.1	15,890	69.9	15,910
	130	63.7	13,580	65.7	13,590	67.5	13,600
	140	61.3	11,630	63.3	11,640	65.1	11,660
	150	58.8	9,960	60.8	9,970	62.6	9,980
	160	56.3	8,520	58.3	8,530	60.0	8,550
	170	53.7	7,260	55.7	7,270	57.3	7,280
	180	51.0	6,150	52.9	6,160	54.6	6,180
	190	48.2	5,180	50.1	5,180	51.7	5,200
	200	45.2	4,310	47.1	4,320	48.6	4,340
	210	42.1	3,540	44.0	3,550	45.4	3,570

	45	82.8	28,840*	-	-	-	-
	50	81.8	28,460*	-	-	-	-
	60	79.8	27,720*	81.8	24,760*	-	-
	70	77.7	26,950*	79.7	24,230*	81.6	22,130*
	80	75.6	26,270*	77.6	23,790*	79.5	21,800*
	90	73.5	25,560*	75.5	23,260*	77.4	20,630*
	100	71.3	21,600	73.3	21,600	75.2	19,490*
	110	69.1	18,210	71.1	18,220	73.0	18,230
<b>220' (67.1 m)</b>	120	66.9	15,440	68.9	15,450	70.7	15,460
	130	64.7	13,140	66.7	13,140	68.4	13,160
	140	62.4	11,190	64.4	11,200	66.1	11,210
	150	60.1	9,520	62.0	9,520	63.7	9,540
	160	57.7	8,080	59.6	8,080	61.3	8,100
	170	55.2	6,810	57.1	6,820	58.7	6,830
	180	52.7	5,700	54.5	5,710	56.1	5,730
	190	50.0	4,720	51.9	4,730	53.4	4,750
	200	47.3	3,860	49.1	3,860	50.6	3,880
	210	44.4	3,080	46.2	3,090	47.6	3,110
	220	41.3	2,390	43.1	2,400	44.4	2,420



**WITH 77SI HAMMERHEAD TIP BOOM AND 102,000 POUND UPPER COUNTERWEIGHT #16HL JIB**

102,000 lb 360° ANSI B 30.5

**70' (21.3 m) Jib length**

Boom length	Jib Radius (Feet)	5.0 Deg offset Boom Angle	5.0 Deg offset Rating (Pounds)	15.0 Deg offset Boom Angle	15.0 Deg offset Rating (Pounds)	25.0 Deg offset Boom Angle	25.0 Deg offset Rating (Pounds)
	42	82.9	22,110*	-	-	-	-
	50	81.0	21,490*	-	-	-	-
	60	78.7	20,710*	81.4	18,400*	-	-
	70	76.4	19,960*	79.0	17,880*	81.6	16,230*
	80	74.0	19,300*	76.7	17,360*	79.2	15,910*
	90	71.6	18,660*	74.2	16,880*	76.7	15,460*
<b>180' (54.9 m)</b>	100	69.2	18,060*	71.8	16,460*	74.2	15,030*
	110	66.7	17,480*	69.3	15,990*	71.7	14,640*
	120	64.2	16,990*	66.8	15,490*	69.1	14,300*
	130	61.6	15,880*	64.1	15,070*	66.5	13,810*
	140	58.9	13,140	61.5	13,150	63.7	13,170*
	150	56.2	11,480	58.7	11,490	60.9	11,510
	160	53.4	10,040	55.9	10,050	58.0	10,070
	170	50.4	8,790	52.9	8,800	55.0	8,820
	180	47.3	7,690	49.8	7,700	51.8	7,720

	43	82.9	22,040*	-	-	-	-
	50	81.4	21,550*	-	-	-	-
	60	79.2	20,740*	81.7	18,420*	-	-
	70	76.9	20,000*	79.5	17,870*	81.9	16,210*
	80	74.6	19,340*	77.2	17,450*	79.6	15,880*
	90	72.3	18,800*	74.9	16,980*	77.2	15,460*
<b>190' (57.9 m)</b>	100	70.0	18,210*	72.5	16,490*	74.9	15,030*
	110	67.7	17,620*	70.2	16,110*	72.5	14,660*
	120	65.2	16,950	67.7	15,620*	70.0	14,350*
	130	62.8	14,640	65.2	14,650	67.5	14,010*
	140	60.3	12,700	62.7	12,710	64.9	12,720
	150	57.7	11,030	60.1	11,040	62.2	11,050
	160	55.0	9,590	57.4	9,600	59.5	9,620
	170	52.2	8,340	54.6	8,350	56.7	8,360
	180	49.4	7,240	51.7	7,250	53.7	7,270
	190	46.4	6,260	48.7	6,270	50.6	6,290

	44	83.0	22,000*	-	-	-	-
	50	81.7	21,520*	-	-	-	-
	60	79.6	20,770*	82.0	18,450*	-	-
	70	77.4	20,140*	79.9	17,950*	82.2	16,190*
	80	75.2	19,470*	77.7	17,420*	80.0	15,860*
	90	73.0	18,860*	75.5	17,010*	77.7	15,530*
	100	70.8	18,290*	73.2	16,600*	75.5	15,100*
	110	68.5	17,770*	70.9	16,170*	73.2	14,740*
<b>200' (61.0 m)</b>	120	66.2	16,520	68.6	15,740*	70.8	14,380*
	130	63.9	14,230	66.3	14,240	68.4	14,120*
	140	61.5	12,280	63.8	12,290	66.0	12,310
	150	59.0	10,610	61.4	10,620	63.4	10,640
	160	56.5	9,170	58.8	9,180	60.9	9,200
	170	53.9	7,920	56.2	7,930	58.2	7,940
	180	51.2	6,810	53.5	6,820	55.4	6,840
	190	48.4	5,840	50.6	5,850	52.5	5,870
	200	45.4	4,970	47.6	4,980	49.4	5,000

Boom length	Jib Radius (Feet)	5.0 Deg offset Boom Angle	5.0 Deg offset Rating (Pounds)	15.0 Deg offset Boom Angle	15.0 Deg offset Rating (Pounds)	25.0 Deg offset Boom Angle	25.0 Deg offset Rating (Pounds)
	46	82.8	21,860*	-	-	-	-
	50	82.0	21,580*	-	-	-	-
	60	79.9	20,880*	82.3	18,400*	-	-
	70	77.9	20,210*	80.2	17,960*	82.5	16,210*
	80	75.8	19,580*	78.1	17,510*	80.4	15,860*
	90	73.6	18,980*	76.0	17,020*	78.2	15,510*
	100	71.5	18,440*	73.8	16,620*	76.0	15,150*
	110	69.3	17,880*	71.7	16,200*	73.8	14,810*
<b>210' (64.0 m)</b>	120	67.1	16,080	69.4	15,890*	71.6	14,460*
	130	64.9	13,780	67.2	13,780	69.3	13,800
	140	62.6	11,830	64.9	11,840	66.9	11,860
	150	60.2	10,160	62.5	10,170	64.5	10,180
	160	57.8	8,720	60.1	8,730	62.1	8,740
	170	55.4	7,460	57.6	7,470	59.5	7,490
	180	52.8	6,350	55.0	6,360	56.9	6,380
	190	50.2	5,370	52.4	5,380	54.2	5,400
	200	47.4	4,510	49.6	4,520	51.4	4,540
	210	44.6	3,720	46.7	3,730	48.4	3,760

	47	82.9	21,780*	-	-	-	-
	50	82.3	21,550*	-	-	-	-
	60	80.3	20,910*	82.6	18,430*	-	-
	70	78.3	20,250*	80.6	17,960*	82.8	16,120*
	80	76.3	19,620*	78.6	17,490*	80.7	15,860*
	90	74.2	19,010*	76.5	17,100*	78.6	15,550*
	100	72.2	18,540*	74.4	16,640*	76.5	15,210*
	110	70.1	17,970*	72.3	16,290*	74.4	14,820*
<b>220' (67.1 m)</b>	120	68.0	15,640	70.2	15,650	72.2	14,530*
	130	65.8	13,330	68.0	13,340	70.1	13,360
	140	63.6	11,390	65.8	11,400	67.8	11,410
	150	61.4	9,710	63.6	9,720	65.5	9,740
	160	59.1	8,270	61.3	8,280	63.2	8,300
	170	56.7	7,010	58.9	7,020	60.8	7,040
	180	54.3	5,900	56.5	5,910	58.3	5,930
	190	51.8	4,920	53.9	4,930	55.8	4,950
	200	49.2	4,050	51.3	4,060	53.1	4,080
	210	46.5	3,270	48.6	3,280	50.3	3,300
	220	43.7	2,570	45.8	2,590	47.4	2,610

**WITH 77SI HAMMERHEAD TIP BOOM AND 102,000 POUND UPPER COUNTERWEIGHT  
#16HL JIB**

102,000 lb 360° ANSI B 30.5

**80' (24.4 m) Jib length**

Boom length	Jib Radius (Feet)	5.0 Deg offset		15.0 Deg offset		25.0 Deg offset	
		Boom Angle	Rating (Pounds)	Boom Angle	Rating (Pounds)	Boom Angle	Rating (Pounds)
	46	83.0	17,280*	-	-	-	-
	50	82.2	16,980*	-	-	-	-
	60	80.1	16,300*	82.9	14,140*	-	-
	70	78.0	15,680*	80.8	13,680*	-	-
	80	75.9	15,040*	78.7	13,290*	81.2	11,670*
	90	73.8	14,490*	76.5	12,790*	79.1	11,250*
	100	71.7	13,980*	74.4	12,330*	76.9	10,910*
	110	69.5	13,550*	72.2	11,890*	74.7	10,610*
<b>200' (61.0 m)</b>	120	67.3	13,050*	70.0	11,440*	72.4	10,320*
	130	65.0	12,490*	67.7	11,120*	70.1	10,090*
	140	62.8	12,030*	65.4	10,780*	67.8	9,860*
	150	60.4	10,800	63.0	10,480*	65.4	9,650*
	160	58.0	9,360	60.6	9,370	62.9	9,390
	170	55.6	8,100	58.1	8,110	60.4	8,130
	180	53.0	6,990	55.5	7,000	57.7	7,030
	190	50.4	6,010	52.9	6,020	55.0	6,050
	200	47.6	5,150	50.1	5,160	52.2	5,180

	48	82.8	17,170*	-	-	-	-
	50	82.4	17,020*	-	-	-	-
	60	80.5	16,340*	-	-	-	-
	70	78.4	15,700*	81.1	13,690*	-	-
	80	76.4	15,120*	79.1	13,300*	81.5	11,660*
	90	74.4	14,600*	77.0	12,870*	79.5	11,310*
	100	72.3	14,100*	74.9	12,370*	77.4	10,970*
	110	70.2	13,610*	72.8	11,940*	75.2	10,650*
<b>210' (64.0 m)</b>	120	68.1	13,210*	70.7	11,550*	73.1	10,360*
	130	66.0	12,700*	68.5	11,190*	70.9	10,140*
	140	63.8	12,020	66.3	10,840*	68.6	9,910*
	150	61.5	10,350	64.1	10,360	66.3	9,670*
	160	59.3	8,900	61.8	8,910	64.0	8,930
	170	56.9	7,640	59.4	7,650	61.6	7,670
	180	54.5	6,530	57.0	6,550	59.1	6,570
	190	52.0	5,560	54.4	5,570	56.5	5,590
	200	49.4	4,680	51.8	4,690	53.9	4,720
	210	46.7	3,910	49.1	3,920	51.1	3,940

Boom length	Jib Radius (Feet)	5.0 Deg offset		15.0 Deg offset		25.0 Deg offset	
		Boom Angle	Rating (Pounds)	Boom Angle	Rating (Pounds)	Boom Angle	Rating (Pounds)
	49	82.9	17,060*	-	-	-	-
	50	82.7	17,020*	-	-	-	-
	60	80.8	16,350*	-	-	-	-
	70	78.8	15,760*	81.4	13,700*	-	-
	80	76.9	15,220*	79.4	13,320*	81.8	11,670*
	90	74.9	14,670*	77.5	12,940*	79.8	11,310*
	100	72.9	14,210*	75.5	12,460*	77.8	10,970*
	110	70.9	13,700*	73.4	12,000*	75.8	10,670*
<b>220' (67.1 m)</b>	120	68.9	13,280*	71.4	11,650*	73.7	10,400*
	130	66.8	12,830*	69.3	11,250*	71.6	10,130*
	140	64.7	11,570	67.2	10,920*	69.4	9,920*
	150	62.6	9,910	65.0	9,920	67.2	9,730*
	160	60.4	8,460	62.8	8,470	65.0	8,480
	170	58.2	7,190	60.6	7,200	62.7	7,220
	180	55.9	6,090	58.2	6,100	60.3	6,120
	190	53.5	5,100	55.9	5,110	57.9	5,130
	200	51.1	4,230	53.4	4,240	55.4	4,260
	210	48.5	3,450	50.8	3,460	52.8	3,490
	220	45.9	2,760	48.2	2,770	50.0	2,790



**WITH 77SI HAMMERHEAD TIP BOOM AND 116,400 POUND COUNTERWEIGHT  
#16HL JIB**

108,400 lb + 8,000 lb carbody counterweight

360°

ANSI B 30.5

**40' (12.2 m) Jib length**

Boom length	Jib Radius (Feet)	5.0 Deg offset		15.0 Deg offset		25.0 Deg offset	
		Boom Angle	Rating (Pounds)	Boom Angle	Rating (Pounds)	Boom Angle	Rating (Pounds)
	26	82.8	32,000*	-	-	-	-
	30	81.2	32,000*	-	-	-	-
	35	79.1	32,000*	81.8	32,000*	-	-
	40	77.0	32,000*	79.7	32,000*	82.3	32,000*
<b>100' (30.5 m)</b>	50	72.8	32,000*	75.5	32,000*	78.0	31,980*
	60	68.5	32,000*	71.2	32,000*	73.6	28,600*
	70	64.1	32,000*	66.7	31,930*	69.1	25,990*
	80	59.4	32,000*	62.0	28,940*	64.3	23,950*
	90	54.6	30,530*	57.1	26,570*	59.3	22,240*
	100	49.3	27,580*	51.8	24,610*	53.9	20,800*

	27	82.9	32,000*	-	-	-	-
	30	81.7	32,000*	-	-	-	-
	35	79.8	32,000*	82.4	32,000*	-	-
	40	77.9	32,000*	80.4	32,000*	82.8	32,000*
<b>110' (33.5 m)</b>	50	74.0	32,000*	76.5	32,000*	78.9	32,000*
	60	70.0	32,000*	72.5	32,000*	74.8	29,340*
	70	65.9	32,000*	68.4	32,000*	70.6	26,800*
	80	61.7	32,000*	64.1	30,140*	66.3	24,700*
	90	57.2	31,930	59.6	27,640*	61.7	22,940*
	100	52.6	27,520	54.9	25,570*	56.9	21,540*
	110	47.5	24,000	49.8	23,870*	51.7	20,370*

	28	83.0	32,000*	-	-	-	-
	30	82.3	32,000*	-	-	-	-
	35	80.5	32,000*	82.8	32,000*	-	-
	40	78.7	32,000*	81.0	32,000*	-	-
<b>120' (36.6 m)</b>	50	75.0	32,000*	77.4	32,000*	79.6	32,000*
	60	71.3	32,000*	73.6	32,000*	75.8	30,030*
	70	67.5	32,000*	69.8	32,000*	71.9	27,480*
	80	63.6	32,000*	65.9	31,300*	67.9	25,380*
	90	59.5	31,500	61.8	28,700*	63.8	23,650*
	100	55.3	27,090	57.5	26,600*	59.4	22,160*
	110	50.8	23,570	52.9	23,580	54.8	20,990*
	120	45.9	20,680	48.1	20,690	49.8	19,920*

	30	82.7	32,000*	-	-	-	-
	35	81.0	32,000*	-	-	-	-
	40	79.3	32,000*	81.6	32,000*	-	-
	50	75.9	32,000*	78.1	32,000*	80.2	32,000*
<b>130' (39.6 m)</b>	60	72.4	32,000*	74.6	32,000*	76.7	30,690*
	70	68.9	32,000*	71.1	32,000*	73.1	28,120*
	80	65.2	32,000*	67.4	32,000*	69.3	26,010*
	90	61.5	31,070	63.6	29,710*	65.5	24,290*
	100	57.6	26,660	59.7	26,660	61.5	22,770*
	110	53.5	23,120	55.5	23,130	57.3	21,590*
	120	49.1	20,230	51.2	20,240	52.8	20,250
	130	44.5	17,830	46.5	17,830	48.0	17,840

Boom length	Jib Radius (Feet)	5.0 Deg offset		15.0 Deg offset		25.0 Deg offset	
		Boom Angle	Rating (Pounds)	Boom Angle	Rating (Pounds)	Boom Angle	Rating (Pounds)
	31	82.8	32,000*	-	-	-	-
	35	81.5	32,000*	-	-	-	-
	40	79.9	32,000*	82.0	32,000*	-	-
	50	76.7	32,000*	78.8	32,000*	80.8	32,000*
	60	73.4	32,000*	75.5	32,000*	77.4	31,210*
	70	70.1	32,000*	72.2	32,000*	74.1	28,730*
<b>140' (42.7 m)</b>	80	66.7	32,000*	68.7	32,000*	70.6	26,600*
	90	63.2	30,630	65.2	30,640	67.0	24,840*
	100	59.6	26,220	61.6	26,230	63.3	23,430*
	110	55.8	22,690	57.8	22,700	59.5	22,110*
	120	51.8	19,800	53.8	19,800	55.4	19,820
	130	47.7	17,390	49.6	17,400	51.1	17,410
	140	43.2	15,360	45.0	15,360	46.5	15,380

	32	82.9	32,000*	-	-	-	-
	35	82.0	32,000*	-	-	-	-
	40	80.5	32,000*	82.5	32,000*	-	-
	50	77.4	32,000*	79.4	32,000*	81.3	32,000*
	60	74.3	32,000*	76.3	32,000*	78.1	31,750*
	70	71.2	32,000*	73.1	32,000*	74.9	29,330*
<b>150' (45.7 m)</b>	80	68.0	32,000*	69.9	32,000*	71.7	27,220*
	90	64.7	30,250	66.6	30,260	68.3	25,420*
	100	61.3	25,840	63.2	25,840	64.9	23,940*
	110	57.8	22,300	59.7	22,300	61.3	22,310
	120	54.2	19,410	56.0	19,410	57.6	19,430
	130	50.4	17,000	52.2	17,000	53.7	17,010
	140	46.3	14,960	48.1	14,970	49.5	14,980
	150	41.9	13,220	43.7	13,230	45.0	13,240

	33	82.9	32,000*	-	-	-	-
	35	82.4	32,000*	-	-	-	-
	40	80.9	32,000*	82.8	32,000*	-	-
	50	78.0	32,000*	79.9	32,000*	81.7	32,000*
	60	75.1	32,000*	77.0	32,000*	78.8	32,000*
	70	72.1	32,000*	74.0	32,000*	75.7	29,880*
<b>160' (48.8 m)</b>	80	69.1	32,000*	71.0	32,000*	72.7	27,770*
	90	66.0	29,820	67.9	29,830	69.5	25,960*
	100	62.9	25,390	64.7	25,400	66.3	24,470*
	110	59.6	21,860	61.4	21,870	63.0	21,880
	120	56.2	18,960	58.0	18,970	59.5	18,980
	130	52.7	16,550	54.4	16,550	55.9	16,560
	140	49.0	14,510	50.7	14,510	52.1	14,520
	150	45.1	12,770	46.7	12,780	48.1	12,790
	160	40.8	11,260	42.4	11,270	43.7	11,280

**WITH 77SI HAMMERHEAD TIP BOOM AND 116,400 POUND COUNTERWEIGHT  
#16HL JIB**

108,400 lb + 8,000 lb carbody counterweight

360°

ANSI B 30.5

**40' (12.2 m) Jib length**

Boom length	Jib Radius (Feet)	5.0 Deg offset		15.0 Deg offset		25.0 Deg offset	
		Boom Angle	Rating (Pounds)	Boom Angle	Rating (Pounds)	Boom Angle	Rating (Pounds)
	34	83.0	32,000*	-	-	-	-
	35	82.7	32,000*	-	-	-	-
	40	81.4	32,000*	-	-	-	-
	50	78.6	32,000*	80.4	32,000*	82.1	32,000*
	60	75.8	32,000*	77.6	32,000*	79.3	32,000*
	70	73.0	32,000*	74.8	32,000*	76.4	30,360*
<b>170'</b> <b>(51.8 m)</b>	80	70.2	32,000*	71.9	32,000*	73.5	28,290*
	90	67.2	29,390	69.0	29,390	70.6	26,460*
	100	64.3	24,970	66.0	24,980	67.5	24,990
	110	61.2	21,430	62.9	21,430	64.4	21,440
	120	58.0	18,520	59.7	18,530	61.2	18,540
	130	54.8	16,110	56.4	16,110	57.9	16,120
	140	51.3	14,070	53.0	14,080	54.4	14,090
	150	47.7	12,320	49.3	12,330	50.7	12,340
	160	43.9	10,820	45.5	10,830	46.7	10,840
	170	39.8	9,510	41.3	9,510	42.5	9,530

	36	82.8	32,000*	-	-	-	-
	40	81.8	32,000*	-	-	-	-
	50	79.1	32,000*	80.9	32,000*	82.5	32,000*
	60	76.5	32,000*	78.2	32,000*	79.8	32,000*
	70	73.8	32,000*	75.5	32,000*	77.1	30,790*
	80	71.1	32,000*	72.8	32,000*	74.3	28,770*
<b>180'</b> <b>(54.9 m)</b>	90	68.3	28,960	70.0	28,960	71.5	26,980*
	100	65.5	24,530	67.2	24,530	68.7	24,540
	110	62.6	20,980	64.3	20,990	65.7	21,000
	120	59.6	18,080	61.3	18,080	62.7	18,100
	130	56.6	15,660	58.2	15,670	59.6	15,680
	140	53.4	13,620	55.0	13,630	56.3	13,640
	150	50.1	11,870	51.6	11,880	52.9	11,890
	160	46.6	10,360	48.1	10,370	49.3	10,380
	170	42.8	9,040	44.3	9,050	45.5	9,060
	180	38.8	7,900	40.3	7,910	41.3	7,920

	37	82.9	32,000*	-	-	-	-
	40	82.1	32,000*	-	-	-	-
	50	79.6	32,000*	81.3	32,000*	82.8	32,000*
	60	77.1	32,000*	78.7	32,000*	80.3	32,000*
	70	74.5	32,000*	76.2	32,000*	77.7	31,170*
	80	71.9	32,000*	73.6	32,000*	75.0	29,160*
	90	69.3	28,530	70.9	28,530	72.4	27,430*
	100	66.6	24,100	68.2	24,100	69.7	24,110
<b>190'</b> <b>(57.9 m)</b>	110	63.9	20,550	65.5	20,550	66.9	20,570
	120	61.1	17,650	62.7	17,650	64.0	17,660
	130	58.2	15,220	59.8	15,230	61.1	15,240
	140	55.2	13,180	56.8	13,180	58.1	13,190
	150	52.1	11,430	53.6	11,440	54.9	11,450
	160	48.9	9,920	50.4	9,930	51.6	9,940
	170	45.5	8,600	46.9	8,600	48.1	8,620
	180	41.8	7,450	43.3	7,450	44.3	7,470
	190	37.9	6,420	39.3	6,430	40.3	6,450

Boom length	Jib Radius (Feet)	5.0 Deg offset		15.0 Deg offset		25.0 Deg offset	
		Boom Angle	Rating (Pounds)	Boom Angle	Rating (Pounds)	Boom Angle	Rating (Pounds)
	38	82.9	32,000*	-	-	-	-
	40	82.4	32,000*	-	-	-	-
	50	80.0	32,000*	81.6	32,000*	-	-
	60	77.6	32,000*	79.2	32,000*	80.7	32,000*
	70	75.2	32,000*	76.7	32,000*	78.2	31,700*
	80	72.7	32,000*	74.3	32,000*	75.7	29,610*
	90	70.2	28,140	71.7	28,140	73.2	27,840*
	100	67.7	23,710	69.2	23,710	70.6	23,720
<b>200'</b> <b>(61.0 m)</b>	110	65.1	20,150	66.6	20,150	67.9	20,160
	120	62.4	17,240	63.9	17,250	65.2	17,260
	130	59.7	14,820	61.2	14,820	62.5	14,830
	140	56.9	12,780	58.3	12,780	59.6	12,800
	150	54.0	11,020	55.4	11,030	56.6	11,040
	160	50.9	9,510	52.4	9,510	53.6	9,530
	170	47.8	8,190	49.2	8,200	50.3	8,210
	180	44.5	7,030	45.8	7,030	46.9	7,050
	190	40.9	6,010	42.3	6,020	43.3	6,030
	200	37.1	5,100	38.4	5,110	39.3	5,120

	39	83.0	32,000*	-	-	-	-
	40	82.7	32,000*	-	-	-	-
	50	80.4	32,000*	82.0	32,000*	-	-
	60	78.1	32,000*	79.6	32,000*	81.1	32,000*
	70	75.8	32,000*	77.3	32,000*	78.7	32,000*
	80	73.4	32,000*	74.9	32,000*	76.3	30,050*
	90	71.0	27,700	72.5	27,700	73.9	27,710
	100	68.6	23,270	70.1	23,270	71.4	23,280
<b>210'</b> <b>(64.0 m)</b>	110	66.1	19,720	67.6	19,720	68.9	19,730
	120	63.6	16,810	65.0	16,810	66.3	16,820
	130	61.0	14,380	62.4	14,390	63.7	14,400
	140	58.4	12,330	59.8	12,340	61.0	12,350
	150	55.6	10,570	57.0	10,580	58.2	10,590
	160	52.8	9,060	54.2	9,060	55.3	9,080
	170	49.8	7,740	51.2	7,740	52.3	7,760
	180	46.8	6,570	48.1	6,580	49.2	6,590
	190	43.5	5,550	44.8	5,560	45.8	5,570
	200	40.0	4,640	41.3	4,650	42.3	4,660
	210	36.3	3,820	37.5	3,830	38.4	3,850

	41	82.8	32,000*	-	-	-	-
	50	80.8	32,000*	82.3	32,000*	-	-
	60	78.6	32,000*	80.0	32,000*	81.4	32,000*
	70	76.3	32,000*	77.8	32,000*	79.1	32,000*
	80	74.1	32,000*	75.5	32,000*	76.8	30,460*
	90	71.8	27,280	73.2	27,280	74.5	27,290
	100	69.4	22,830	70.9	22,840	72.2	22,850
	110	67.1	19,280	68.5	19,290	69.8	19,300
<b>220'</b> <b>(67.1 m)</b>	120	64.7	16,380	66.1	16,380	67.3	16,390
	130	62.2	13,940	63.6	13,950	64.8	13,960
	140	59.7	11,890	61.1	11,890	62.3	11,900
	150	57.1	10,140	58.5	10,140	59.6	10,150
	160	54.4	8,620	55.8	8,630	56.9	8,640
	170	51.7	7,290	53.0	7,290	54.1	7,300
	180	48.8	6,130	50.1	6,130	51.2	6,150
	190	45.8	5,100	47.1	5,110	48.1	5,120
	200	42.6	4,180	43.9	4,190	44.8	4,200
	210	39.2	3,370	40.5	3,370	41.3	3,390
	220	35.6	2,650	36.7	2,660	37.6	2,670



**WITH 77SI HAMMERHEAD TIP BOOM AND 116,400 POUND COUNTERWEIGHT  
#16HL JIB**

108,400 lb + 8,000 lb carbody counterweight

360°

ANSI B 30.5

**50' (15.2 m) Jib length**

Boom length	Jib Radius (Feet)	5.0 Deg offset		15.0 Deg offset		25.0 Deg offset	
		Boom Angle	Rating (Pounds)	Boom Angle	Rating (Pounds)	Boom Angle	Rating (Pounds)
	32	82.7	32,000*	-	-	-	-
	35	81.8	32,000*	-	-	-	-
	40	80.2	32,000*	82.8	29,150*	-	-
	50	77.0	30,830*	79.6	28,270*	82.1	26,350*
<b>130' (39.6 m)</b>	60	73.7	29,600*	76.3	27,480*	78.8	25,720*
	70	70.4	28,670*	73.0	26,620*	75.4	23,990*
	80	67.0	27,710*	69.5	26,010*	71.9	22,090*
	90	63.5	26,850*	66.0	25,290*	68.3	20,610*
	100	59.8	26,090*	62.3	23,680*	64.6	19,300*
	110	56.1	23,410	58.5	22,060*	60.7	18,180*
	120	52.1	20,520	54.6	20,520	56.7	17,250*
	130	47.9	18,110	50.3	18,120	52.3	16,520*

	33	82.8	32,000*	-	-	-	-
	35	82.2	32,000*	-	-	-	-
	40	80.7	32,000*	-	-	-	-
	50	77.7	30,900*	80.2	28,370*	82.5	26,340*
	60	74.6	29,910*	77.1	27,590*	79.4	25,730*
	70	71.4	28,870*	73.9	26,840*	76.2	24,370*
<b>140' (42.7 m)</b>	80	68.2	27,940*	70.7	26,150*	72.9	22,550*
	90	65.0	27,180*	67.4	25,490*	69.6	21,090*
	100	61.6	26,330*	64.0	24,400*	66.1	19,780*
	110	58.1	22,980	60.4	22,810*	62.5	18,700*
	120	54.4	20,080	56.8	20,090	58.8	17,730*
	130	50.6	17,670	52.9	17,670	54.9	16,910*
	140	46.6	15,640	48.8	15,650	50.7	15,660

	34	82.9	32,000*	-	-	-	-
	35	82.6	32,000*	-	-	-	-
	40	81.2	32,000*	-	-	-	-
	50	78.3	31,150*	80.7	28,380*	82.9	26,290*
	60	75.4	30,070*	77.7	27,630*	79.9	25,700*
	70	72.4	29,090*	74.7	26,860*	76.9	24,840*
<b>150' (45.7 m)</b>	80	69.4	28,250*	71.7	26,310*	73.8	23,000*
	90	66.3	27,440*	68.6	25,640*	70.7	21,460*
	100	63.1	26,110	65.4	25,080*	67.5	20,230*
	110	59.9	22,580	62.1	22,590	64.1	19,050*
	120	56.5	19,680	58.7	19,690	60.7	18,080*
	130	52.9	17,270	55.1	17,270	57.0	17,290
	140	49.2	15,240	51.4	15,240	53.2	15,260
	150	45.3	13,490	47.4	13,500	49.1	13,510

	35	83.0	32,000*	-	-	-	-
	40	81.6	32,000*	-	-	-	-
	50	78.8	31,260*	81.1	28,390*	-	-
	60	76.1	30,270*	78.3	27,640*	80.4	25,770*
	70	73.3	29,280*	75.5	26,960*	77.6	25,200*
	80	70.4	28,410*	72.6	26,360*	74.7	23,360*
<b>160' (48.8 m)</b>	90	67.5	27,590*	69.7	25,740*	71.7	21,860*
	100	64.5	25,670	66.7	25,230*	68.6	20,580*
	110	61.4	22,140	63.6	22,140	65.5	19,500*
	120	58.3	19,230	60.4	19,240	62.3	18,540*
	130	55.0	16,820	57.1	16,820	58.9	16,840
	140	51.6	14,770	53.6	14,780	55.4	14,790
	150	48.0	13,030	50.0	13,040	51.7	13,060
	160	44.1	11,530	46.1	11,540	47.7	11,560

Boom length	Jib Radius (Feet)	5.0 Deg offset		15.0 Deg offset		25.0 Deg offset	
		Boom Angle	Rating (Pounds)	Boom Angle	Rating (Pounds)	Boom Angle	Rating (Pounds)
	37	82.8	32,000*	-	-	-	-
	40	82.0	32,000*	-	-	-	-
	50	79.4	31,370*	81.5	28,420*	-	-
	60	76.7	30,340*	78.9	27,770*	80.9	25,780*
	70	74.0	29,470*	76.2	27,070*	78.2	25,250*
	80	71.3	28,560*	73.4	26,440*	75.4	23,770*
<b>170' (51.8 m)</b>	90	68.5	27,780*	70.7	25,950*	72.6	22,250*
	100	65.7	25,240	67.8	25,240	69.7	20,960*
	110	62.8	21,690	64.9	21,700	66.8	19,890*
	120	59.9	18,800	61.9	18,810	63.7	18,820
	130	56.8	16,380	58.8	16,390	60.6	16,400
	140	53.6	14,330	55.6	14,340	57.3	14,350
	150	50.3	12,590	52.3	12,600	53.9	12,610
	160	46.8	11,090	48.7	11,090	50.3	11,110
	170	43.1	9,760	44.9	9,770	46.4	9,790

	38	82.8	32,000*	-	-	-	-
	40	82.3	32,000*	-	-	-	-
	50	79.8	31,400*	81.9	28,460*	-	-
	60	77.3	30,400*	79.4	27,770*	81.3	25,760*
	70	74.7	29,540*	76.8	27,180*	78.7	25,300*
	80	72.2	28,800*	74.2	26,610*	76.1	24,140*
<b>180' (54.9 m)</b>	90	69.5	28,050*	71.5	26,030*	73.4	22,600*
	100	66.8	24,800	68.8	24,800	70.7	21,330*
	110	64.1	21,250	66.1	21,260	67.9	20,270*
	120	61.3	18,350	63.3	18,350	65.0	18,360
	130	58.4	15,920	60.4	15,930	62.1	15,940
	140	55.4	13,890	57.4	13,890	59.0	13,910
	150	52.3	12,130	54.2	12,140	55.8	12,150
	160	49.1	10,620	51.0	10,630	52.5	10,640
	170	45.7	9,310	47.5	9,310	49.0	9,330
	180	42.1	8,160	43.8	8,160	45.2	8,180

	39	82.9	32,000*	-	-	-	-
	40	82.6	32,000*	-	-	-	-
	50	80.2	31,400*	82.2	28,430*	-	-
	60	77.8	30,600*	79.8	27,810*	81.7	25,690*
	70	75.4	29,700*	77.4	27,180*	79.2	25,250*
	80	72.9	28,930*	74.9	26,670*	76.7	24,500*
	90	70.4	28,210*	72.3	26,110*	74.1	23,030*
	100	67.9	24,370	69.8	24,370	71.5	21,680*
<b>190' (57.9 m)</b>	110	65.3	20,820	67.2	20,820	68.9	20,600*
	120	62.6	17,910	64.5	17,920	66.2	17,930
	130	59.9	15,490	61.8	15,500	63.4	15,510
	140	57.1	13,440	58.9	13,450	60.5	13,460
	150	54.2	11,690	56.0	11,700	57.6	11,710
	160	51.1	10,170	53.0	10,180	54.5	10,190
	170	48.0	8,850	49.8	8,860	51.2	8,870
	180	44.7	7,700	46.4	7,700	47.8	7,720
	190	41.1	6,680	42.8	6,690	44.1	6,710

**WITH 77SI HAMMERHEAD TIP BOOM AND 116,400 POUND COUNTERWEIGHT  
#16HL JIB**

108,400 lb + 8,000 lb carbody counterweight

360°

ANSI B 30.5

**50' (15.2 m) Jib length**

Boom length	Jib Radius (Feet)	5.0 Deg offset		15.0 Deg offset		25.0 Deg offset	
		Boom Angle	Rating (Pounds)	Boom Angle	Rating (Pounds)	Boom Angle	Rating (Pounds)
	40	82.9	32,000*	-	-	-	-
	50	80.6	31,470*	82.6	28,410*	-	-
	60	78.3	30,630*	80.2	27,840*	82.0	25,690*
	70	76.0	29,840*	77.9	27,180*	79.6	25,260*
	80	73.6	29,060*	75.5	26,630*	77.2	24,750*
	90	71.2	28,370*	73.1	26,200*	74.8	23,280*
	100	68.8	23,970	70.6	23,970	72.3	22,010*
	110	66.3	20,410	68.1	20,410	69.8	20,420
<b>200' (61.0 m)</b>	120	63.8	17,500	65.6	17,510	67.2	17,520
	130	61.2	15,070	63.0	15,080	64.6	15,090
	140	58.5	13,030	60.3	13,040	61.9	13,050
	150	55.8	11,270	57.6	11,280	59.1	11,290
	160	53.0	9,760	54.7	9,770	56.2	9,780
	170	50.0	8,440	51.8	8,440	53.2	8,460
	180	47.0	7,280	48.7	7,290	50.0	7,300
	190	43.7	6,260	45.4	6,270	46.7	6,280
	200	40.2	5,340	41.9	5,350	43.1	5,370

Boom length	Jib Radius (Feet)	5.0 Deg offset		15.0 Deg offset		25.0 Deg offset	
		Boom Angle	Rating (Pounds)	Boom Angle	Rating (Pounds)	Boom Angle	Rating (Pounds)
	43	82.8	31,930*	-	-	-	-
	50	81.3	31,440*	-	-	-	-
	60	79.2	30,650*	81.0	27,690*	82.6	25,540*
	70	77.0	29,940*	78.8	27,190*	80.4	25,170*
	80	74.9	29,220*	76.6	26,760*	78.2	24,830*
	90	72.7	27,540	74.4	26,200*	76.0	23,890*
	100	70.4	23,100	72.1	23,100	73.7	22,600*
	110	68.2	19,530	69.9	19,540	71.4	19,550
<b>220' (67.1 m)</b>	120	65.9	16,620	67.6	16,630	69.1	16,640
	130	63.5	14,200	65.2	14,200	66.7	14,220
	140	61.1	12,140	62.8	12,150	64.3	12,160
	150	58.7	10,380	60.3	10,390	61.8	10,400
	160	56.1	8,860	57.8	8,870	59.2	8,880
	170	53.5	7,540	55.1	7,540	56.5	7,560
	180	50.8	6,370	52.4	6,380	53.8	6,400
	190	48.0	5,350	49.6	5,350	50.9	5,370
	200	45.1	4,430	46.6	4,440	47.8	4,460
	210	42.0	3,610	43.5	3,620	44.6	3,640
	220	38.6	2,880	40.1	2,890	41.2	2,910

	41	83.0	32,000*	-	-	-	-
	50	81.0	31,480*	82.8	28,380*	-	-
	60	78.8	30,580*	80.6	27,770*	82.3	25,540*
	70	76.5	29,810*	78.3	27,180*	80.1	25,220*
	80	74.3	29,100*	76.1	26,680*	77.8	24,820*
	90	72.0	27,960	73.8	26,250*	75.4	23,600*
	100	69.6	23,530	71.4	23,530	73.1	22,340*
	110	67.3	19,970	69.0	19,980	70.7	19,990
<b>210' (64.0 m)</b>	120	64.9	17,060	66.6	17,060	68.2	17,080
	130	62.4	14,630	64.1	14,640	65.7	14,650
	140	59.9	12,590	61.6	12,590	63.1	12,610
	150	57.3	10,830	59.0	10,830	60.5	10,850
	160	54.6	9,310	56.3	9,320	57.8	9,330
	170	51.9	7,990	53.5	7,990	54.9	8,010
	180	49.0	6,830	50.6	6,830	52.0	6,850
	190	46.0	5,790	47.6	5,800	48.9	5,810
	200	42.8	4,880	44.4	4,890	45.6	4,910
	210	39.4	4,070	41.0	4,070	42.1	4,090

**60' (18.3 m) Jib length**

Boom length	Jib Radius (Feet)	5.0 Deg offset		15.0 Deg offset		25.0 Deg offset	
		Boom Angle	Rating (Pounds)	Boom Angle	Rating (Pounds)	Boom Angle	Rating (Pounds)
	36	82.9	29,880*	-	-	-	-
	40	81.8	29,420*	-	-	-	-
	50	79.1	28,200*	81.8	25,510*	-	-
	60	76.3	27,270*	79.0	24,810*	81.6	22,830*
	70	73.5	26,260*	76.2	24,010*	78.7	21,680*
	80	70.6	25,410*	73.3	23,400*	75.8	20,150*
<b>150' (45.7 m)</b>	90	67.7	24,590*	70.4	22,830*	72.8	18,770*
	100	64.7	23,830*	67.4	21,900*	69.8	17,590*
	110	61.7	22,830	64.3	20,430*	66.6	16,600*
	120	58.5	19,930	61.1	19,150*	63.4	15,730*
	130	55.2	17,520	57.8	17,520	60.0	15,020*
	140	51.8	15,470	54.3	15,480	56.5	14,350*
	150	48.2	13,740	50.7	13,740	52.8	13,760

Boom length	Jib Radius (Feet)	5.0 Deg offset		15.0 Deg offset		25.0 Deg offset	
		Boom Angle	Rating (Pounds)	Boom Angle	Rating (Pounds)	Boom Angle	Rating (Pounds)
	37	83.0	29,680*	-	-	-	-
	40	82.2	29,340*	-	-	-	-
	50	79.6	28,330*	82.2	25,530*	-	-
	60	76.9	27,340*	79.5	24,790*	82.0	22,830*
	70	74.3	26,490*	76.8	24,170*	79.3	21,980*
	80	71.5	25,550*	74.1	23,460*	76.5	20,440*
<b>160' (48.8 m)</b>	90	68.8	24,830*	71.3	22,930*	73.7	19,080*
	100	65.9	24,100*	68.5	22,370*	70.8	17,960*
	110	63.1	22,380	65.6	21,000*	67.8	16,910*
	120	60.1	19,480	62.6	19,490	64.8	16,060*
	130	57.0	17,070	59.5	17,080	61.6	15,300*
	140	53.8	15,020	56.3	15,030	58.4	14,600*
	150	50.5	13,280	52.9	13,290	54.9	13,310
	160	47.0	11,780	49.3	11,780	51.3	11,800



**WITH 77SI HAMMERHEAD TIP BOOM AND 116,400 POUND COUNTERWEIGHT  
#16HL JIB**

108,400 lb + 8,000 lb carbody counterweight

360°

ANSI B 30.5

**60' (18.3 m) Jib length**

Boom length	Jib Radius (Feet)	5.0 Deg offset		15.0 Deg offset		25.0 Deg offset	
		Boom Angle	Rating (Pounds)	Boom Angle	Rating (Pounds)	Boom Angle	Rating (Pounds)
	39	82.8	29,550*	-	-	-	-
	40	82.5	29,420*	-	-	-	-
	50	80.0	28,470*	82.5	25,510*	-	-
	60	77.5	27,490*	80.0	24,890*	82.3	22,760*
	70	75.0	26,600*	77.4	24,230*	79.7	22,280*
	80	72.4	25,710*	74.8	23,620*	77.1	20,740*
<b>170' (51.8 m)</b>	90	69.7	24,950*	72.2	23,000*	74.4	19,370*
	100	67.1	24,260*	69.5	22,450*	71.7	18,210*
	110	64.3	21,950	66.7	21,540*	68.9	17,260*
	120	61.5	19,950	63.9	19,050	66.0	16,350*
	130	58.6	16,620	61.0	16,630	63.1	15,610*
	140	55.6	14,590	58.0	14,590	60.0	14,610
	150	52.5	12,830	54.8	12,840	56.8	12,860
	160	49.3	11,320	51.6	11,330	53.5	11,350
	170	45.9	10,010	48.1	10,010	50.0	10,030

	40	82.8	29,390*	-	-	-	-
	50	80.5	28,490*	82.8	25,460*	-	-
	60	78.0	27,500*	80.4	24,870*	82.7	22,780*
	70	75.6	26,720*	78.0	24,200*	80.2	22,270*
	80	73.1	25,890*	75.5	23,680*	77.7	20,950*
	90	70.6	25,140*	72.9	23,110*	75.1	19,680*
<b>180' (54.9 m)</b>	100	68.1	24,420*	70.4	22,610*	72.5	18,550*
	110	65.5	21,500	67.8	21,500	69.9	17,550*
	120	62.8	18,590	65.1	18,600	67.1	16,680*
	130	60.1	16,170	62.3	16,180	64.4	15,900*
	140	57.3	14,130	59.5	14,140	61.5	14,150
	150	54.4	12,370	56.6	12,380	58.5	12,400
	160	51.4	10,860	53.5	10,870	55.4	10,880
	170	48.2	9,540	50.3	9,550	52.1	9,570
	180	44.9	8,390	47.0	8,400	48.7	8,410

	41	82.9	29,340*	-	-	-	-
	50	80.8	28,440*	-	-	-	-
	60	78.5	27,630*	80.8	24,900*	83.0	22,650*
	70	76.2	26,830*	78.5	24,270*	80.6	22,300*
	80	73.8	26,070*	76.1	23,740*	78.2	21,250*
	90	71.4	25,330*	73.7	23,150*	75.7	19,930*
<b>190' (57.9 m)</b>	100	69.0	24,620	71.2	22,660*	73.3	18,790*
	110	66.5	21,060	68.7	21,060	70.7	17,770*
	120	64.0	18,150	66.2	18,160	68.2	16,920*
	130	61.4	15,730	63.6	15,740	65.5	15,760
	140	58.7	13,680	60.9	13,690	62.8	13,710
	150	56.0	11,920	58.1	11,930	60.0	11,950
	160	53.2	10,410	55.3	10,420	57.1	10,430
	170	50.2	9,100	52.3	9,110	54.1	9,120
	180	47.1	7,930	49.2	7,940	50.9	7,960
	190	43.9	6,910	45.9	6,920	47.5	6,940

Boom length	Jib Radius (Feet)	5.0 Deg offset		15.0 Deg offset		25.0 Deg offset	
		Boom Angle	Rating (Pounds)	Boom Angle	Rating (Pounds)	Boom Angle	Rating (Pounds)
	42	83.0	29,200*	-	-	-	-
	50	81.2	28,520*	-	-	-	-
	60	79.0	27,660*	81.2	24,800*	-	-
	70	76.7	26,840*	78.9	24,240*	81.0	22,240*
	80	74.4	26,140*	76.6	23,710*	78.7	21,460*
	90	72.2	25,420*	74.3	23,200*	76.3	20,160*
	100	69.8	24,210	72.0	22,720*	74.0	19,010*
	110	67.5	20,650	69.6	20,660	71.5	18,020*
<b>200' (61.0 m)</b>	120	65.1	17,750	67.2	17,750	69.1	17,170*
	130	62.6	15,320	64.7	15,330	66.6	15,340
	140	60.1	13,270	62.2	13,280	64.0	13,290
	150	57.5	11,520	59.6	11,530	61.4	11,540
	160	54.8	10,000	56.9	10,010	58.6	10,020
	170	52.1	8,680	54.1	8,680	55.8	8,700
	180	49.2	7,520	51.2	7,530	52.8	7,540
	190	46.2	6,480	48.1	6,490	49.7	6,510
	200	43.0	5,570	44.9	5,580	46.4	5,600

	44	82.8	28,980*	-	-	-	-
	50	81.5	28,460*	-	-	-	-
	60	79.4	27,680*	81.5	24,860*	-	-
	70	77.2	26,940*	79.3	24,250*	81.3	22,180*
	80	75.0	26,190*	77.1	23,760*	79.1	21,670*
	90	72.8	25,480*	74.9	23,320*	76.9	20,370*
	100	70.6	23,770	72.7	22,760*	74.6	19,280*
	110	68.3	20,210	70.4	20,220	72.3	18,300*
<b>210' (64.0 m)</b>	120	66.0	17,300	68.1	17,310	69.9	17,330
	130	63.7	14,880	65.7	14,890	67.5	14,900
	140	61.3	12,820	63.3	12,830	65.1	12,850
	150	58.8	11,060	60.8	11,070	62.6	11,080
	160	56.3	9,540	58.3	9,550	60.0	9,570
	170	53.7	8,220	55.7	8,230	57.3	8,240
	180	51.0	7,050	52.9	7,060	54.6	7,080
	190	48.2	6,030	50.1	6,030	51.7	6,050
	200	45.2	5,110	47.1	5,120	48.6	5,140
	210	42.1	4,290	44.0	4,300	45.4	4,320

	45	82.8	28,830*	-	-	-	-
	50	81.8	28,440*	-	-	-	-
	60	79.8	27,700*	81.8	24,750*	-	-
	70	77.7	26,930*	79.7	24,220*	81.6	22,110*
	80	75.6	26,240*	77.6	23,770*	79.5	21,790*
	90	73.5	25,640*	75.5	23,340*	77.4	20,620*
	100	71.3	23,340	73.3	22,800*	75.2	19,460*
	110	69.1	19,780	71.1	19,790	73.0	18,550*
<b>220' (67.1 m)</b>	120	66.9	16,860	68.9	16,870	70.7	16,880
	130	64.7	14,440	66.7	14,440	68.4	14,460
	140	62.4	12,380	64.4	12,390	66.1	12,400
	150	60.1	10,630	62.0	10,630	63.7	10,650
	160	57.7	9,110	59.6	9,110	61.3	9,130
	170	55.2	7,780	57.1	7,790	58.7	7,800
	180	52.7	6,600	54.5	6,610	56.1	6,630
	190	50.0	5,570	51.9	5,580	53.4	5,600
	200	47.3	4,660	49.1	4,660	50.6	4,680
	210	44.4	3,840	46.2	3,850	47.6	3,870
	220	41.3	3,110	43.1	3,120	44.4	3,140

**WITH 77SI HAMMERHEAD TIP BOOM AND 116,400 POUND COUNTERWEIGHT  
#16HL JIB**

108,400 lb + 8,000 lb carbody counterweight

360°

ANSI B 30.5

**70' (21.3 m) Jib length**

Boom length	Jib Radius (Feet)	5.0 Deg offset		15.0 Deg offset		25.0 Deg offset	
		Boom Angle	Rating (Pounds)	Boom Angle	Rating (Pounds)	Boom Angle	Rating (Pounds)
	42	82.9	22,100*	-	-	-	-
	50	81.0	21,480*	-	-	-	-
	60	78.7	20,700*	81.4	18,390*	-	-
	70	76.4	19,940*	79.0	17,870*	81.6	16,230*
	80	74.0	19,280*	76.7	17,350*	79.2	15,900*
	90	71.6	18,640*	74.2	16,860*	76.7	15,440*
<b>180' (54.9 m)</b>	100	69.2	18,040*	71.8	16,440*	74.2	15,020*
	110	66.7	17,450*	69.3	15,970*	71.7	14,620*
	120	64.2	16,970*	66.8	15,470*	69.1	14,280*
	130	61.6	16,370	64.1	15,050*	66.5	13,780*
	140	58.9	14,330	61.5	14,340	63.7	13,200*
	150	56.2	12,570	58.7	12,580	60.9	12,600
	160	53.4	11,060	55.9	11,070	58.0	11,090
	170	50.4	9,750	52.9	9,760	55.0	9,780
	180	47.3	8,580	49.8	8,590	51.8	8,610

	43	82.9	22,030*	-	-	-	-
	50	81.4	21,540*	-	-	-	-
	60	79.2	20,720*	81.7	18,410*	-	-
	70	76.9	20,070*	79.5	17,940*	81.9	16,200*
	80	74.6	19,410*	77.2	17,440*	79.6	15,860*
	90	72.3	18,780*	74.9	16,960*	77.2	15,510*
<b>190' (57.9 m)</b>	100	70.0	18,190*	72.5	16,540*	74.9	15,080*
	110	67.7	17,600*	70.2	16,090*	72.5	14,700*
	120	65.2	17,130*	67.7	15,600*	70.0	14,330*
	130	62.8	15,930	65.2	15,190*	67.5	14,010*
	140	60.3	13,890	62.7	13,900	64.9	13,380*
	150	57.7	12,130	60.1	12,140	62.2	12,150
	160	55.0	10,610	57.4	10,620	59.5	10,640
	170	52.2	9,300	54.6	9,310	56.7	9,320
	180	49.4	8,130	51.7	8,140	53.7	8,160
	190	46.4	7,100	48.7	7,110	50.6	7,130

	44	83.0	21,990*	-	-	-	-
	50	81.7	21,500*	-	-	-	-
	60	79.6	20,850*	82.0	18,440*	-	-
	70	77.4	20,120*	79.9	17,940*	82.2	16,180*
	80	75.2	19,450*	77.7	17,480*	80.0	15,850*
	90	73.0	18,840*	75.5	16,990*	77.7	15,510*
	100	70.8	18,340*	73.2	16,580*	75.5	15,150*
	110	68.5	17,740*	70.9	16,150*	73.2	14,720*
<b>200' (61.0 m)</b>	120	66.2	17,270*	68.6	15,780*	70.8	14,430*
	130	63.9	15,520	66.3	15,320*	68.4	14,100*
	140	61.5	13,470	63.8	13,480	66.0	13,500
	150	59.0	11,710	61.4	11,720	63.4	11,740
	160	56.5	10,190	58.8	10,200	60.9	10,220
	170	53.9	8,880	56.2	8,890	58.2	8,900
	180	51.2	7,700	53.5	7,710	55.4	7,730
	190	48.4	6,680	50.6	6,690	52.5	6,710
	200	45.4	5,760	47.6	5,770	49.4	5,790

Boom length	Jib Radius (Feet)	5.0 Deg offset		15.0 Deg offset		25.0 Deg offset	
		Boom Angle	Rating (Pounds)	Boom Angle	Rating (Pounds)	Boom Angle	Rating (Pounds)
	46	82.8	21,850*	-	-	-	-
	50	82.0	21,570*	-	-	-	-
	60	79.9	20,860*	82.3	18,390*	-	-
	70	77.9	20,190*	80.2	17,940*	82.5	16,200*
	80	75.8	19,560*	78.1	17,500*	80.4	15,850*
	90	73.6	18,950*	76.0	17,000*	78.2	15,570*
	100	71.5	18,420*	73.8	16,600*	76.0	15,140*
	110	69.3	17,850*	71.7	16,200*	73.8	14,790*
<b>210' (64.0 m)</b>	120	67.1	17,400*	69.4	15,870*	71.6	14,440*
	130	64.9	15,080	67.2	15,080	69.3	14,160*
	140	62.6	13,020	64.9	13,030	66.9	13,050
	150	60.2	11,270	62.5	11,280	64.5	11,290
	160	57.8	9,750	60.1	9,760	62.1	9,770
	170	55.4	8,420	57.6	8,430	59.5	8,450
	180	52.8	7,250	55.0	7,260	56.9	7,280
	190	50.2	6,220	52.4	6,230	54.2	6,250
	200	47.4	5,310	49.6	5,320	51.4	5,340
	210	44.6	4,480	46.7	4,490	48.4	4,520

	47	82.9	21,770*	-	-	-	-
	50	82.3	21,540*	-	-	-	-
	60	80.3	20,900*	82.6	18,420*	-	-
	70	78.3	20,230*	80.6	17,950*	82.8	16,110*
	80	76.3	19,600*	78.6	17,480*	80.7	15,850*
	90	74.2	19,070*	76.5	17,090*	78.6	15,540*
	100	72.2	18,510*	74.4	16,690*	76.5	15,190*
	110	70.1	18,030*	72.3	16,270*	74.4	14,870*
<b>220' (67.1 m)</b>	120	68.0	17,070	70.2	15,950*	72.2	14,510*
	130	65.8	14,630	68.0	14,640	70.1	14,220*
	140	63.6	12,590	65.8	12,600	67.8	12,610
	150	61.4	10,820	63.6	10,830	65.5	10,850
	160	59.1	9,300	61.3	9,310	63.2	9,330
	170	56.7	7,970	58.9	7,980	60.8	8,000
	180	54.3	6,800	56.5	6,810	58.3	6,830
	190	51.8	5,770	53.9	5,780	55.8	5,800
	200	49.2	4,850	51.3	4,860	53.1	4,880
	210	46.5	4,030	48.6	4,040	50.3	4,060
	220	43.7	3,290	45.8	3,310	47.4	3,330



**WITH 77SI HAMMERHEAD TIP BOOM AND 116,400 POUND COUNTERWEIGHT  
#16HL JIB**

108,400 lb + 8,000 lb carbody counterweight

360°

ANSI B 30.5

**80' (24.4 m) Jib length**

Boom length	Jib Radius (Feet)	5.0 Deg offset		15.0 Deg offset		25.0 Deg offset	
		Boom Angle	Rating (Pounds)	Boom Angle	Rating (Pounds)	Boom Angle	Rating (Pounds)
	46	83.0	17,270*	-	-	-	-
	50	82.2	16,970*	-	-	-	-
	60	80.1	16,290*	82.9	14,140*	-	-
	70	78.0	15,670*	80.8	13,670*	-	-
	80	75.9	15,090*	78.7	13,280*	81.2	11,660*
	90	73.8	14,540*	76.5	12,780*	79.1	11,300*
	100	71.7	14,020*	74.4	12,320*	76.9	10,950*
	110	69.5	13,530*	72.2	11,880*	74.7	10,600*
<b>200' (61.0 m)</b>	120	67.3	13,030*	70.0	11,480*	72.4	10,340*
	130	65.0	12,530*	67.7	11,100*	70.1	10,080*
	140	62.8	12,070*	65.4	10,760*	67.8	9,840*
	150	60.4	11,630*	63.0	10,460*	65.4	9,630*
	160	58.0	10,390	60.6	10,200*	62.9	9,480*
	170	55.6	9,060	58.1	9,070	60.4	9,090
	180	53.0	7,890	55.5	7,900	57.7	7,930
	190	50.4	6,860	52.9	6,870	55.0	6,900
	200	47.6	5,950	50.1	5,960	52.2	5,980

	48	82.8	17,160*	-	-	-	-
	50	82.4	17,010*	-	-	-	-
	60	80.5	16,330*	-	-	-	-
	70	78.4	15,690*	81.1	13,680*	-	-
	80	76.4	15,110*	79.1	13,290*	81.5	11,650*
	90	74.4	14,590*	77.0	12,850*	79.5	11,300*
	100	72.3	14,080*	74.9	12,410*	77.4	10,960*
	110	70.2	13,650*	72.8	11,930*	75.2	10,630*
<b>210' (64.0 m)</b>	120	68.1	13,190*	70.7	11,540*	73.1	10,380*
	130	66.0	12,680*	68.5	11,170*	70.9	10,120*
	140	63.8	12,180*	66.3	10,870*	68.6	9,900*
	150	61.5	11,460	64.1	10,570*	66.3	9,690*
	160	59.3	9,940	61.8	9,950	64.0	9,490*
	170	56.9	8,610	59.4	8,620	61.6	8,640
	180	54.5	7,440	57.0	7,460	59.1	7,480
	190	52.0	6,410	54.4	6,420	56.5	6,440
	200	49.4	5,490	51.8	5,500	53.9	5,530
	210	46.7	4,670	49.1	4,680	51.1	4,700

Boom length	Jib Radius (Feet)	5.0 Deg offset		15.0 Deg offset		25.0 Deg offset	
		Boom Angle	Rating (Pounds)	Boom Angle	Rating (Pounds)	Boom Angle	Rating (Pounds)
	49	82.9	17,050*	-	-	-	-
	50	82.7	17,020*	-	-	-	-
	60	80.8	16,340*	-	-	-	-
	70	78.8	15,740*	81.4	13,690*	-	-
	80	76.9	15,200*	79.4	13,310*	81.8	11,660*
	90	74.9	14,660*	77.5	12,920*	79.8	11,300*
	100	72.9	14,190*	75.5	12,440*	77.8	10,960*
	110	70.9	13,750*	73.4	12,040*	75.8	10,660*
<b>220' (67.1 m)</b>	120	68.9	13,320*	71.4	11,630*	73.7	10,390*
	130	66.8	12,810*	69.3	11,250*	71.6	10,160*
	140	64.7	12,370*	67.2	10,950*	69.4	9,950*
	150	62.6	11,020	65.0	10,620*	67.2	9,720*
	160	60.4	9,500	62.8	9,510	65.0	9,520
	170	58.2	8,160	60.6	8,170	62.7	8,190
	180	55.9	7,000	58.2	7,010	60.3	7,030
	190	53.5	5,960	55.9	5,970	57.9	5,990
	200	51.1	5,040	53.4	5,050	55.4	5,070
	210	48.5	4,210	50.8	4,220	52.8	4,250
	220	45.9	3,480	48.2	3,490	50.0	3,510

**NOTES TO LIFTING CAPACITY**

**Warning**

This rating chart is invalid if the crane has been modified or altered by use of other than GENUINE AMERICAN PARTS as such modifications or alterations may affect its capacity or safe operation. See American Crane Corporation Service Bulliten #259.

Ratings in this chart are in POUNDS and do not exceed the percentage of tipping specified for this crane by ANSI B30.5. All ratings require that the crane be standing level on a firm uniformly supporting surface.

Do not lift loads in excess of those shown on this chart. Lifting loads in excess of those shown or operation not in accordance with good operating practice, including limitations shown on page 3499 of Operator's Manual, can cause tipping, structural damage or catastrophic failure.

Asterisk (\*) areas on this chart indicate ratings which are limited by strength of material or factors other than stability (tipping).

„JIB RADIUS IN FEET“ is the horizontal distance at ground level from the crane centerline of rotation to a vertical line through the center of gravity of the suspended load.

When using the main boom fall with jib in place, the main fall ratings must be reduced by the jib effective weight shown on the jib rating chart plus twice the weight of all suspended blocks, slings, rope, etc., at the jib fall. See Appendix A.

Blocks, slings, buckets and other load carrying devices are considered part of the load. The weight of standard hoisting ropes for the rating at a given radius has been calculated as part of the boom point load and need not be considered in determining net allowable loads. See Appendix A.

Ratings shown on this chart make no allowance for such factors as out of plumb loads, wind, poor soil conditions, improper inflation of rubber tires and dynamic effects due to excessive operating speeds. The user (operator) must exercise judgement to make allowance for these conditions. See page 3499 of Operator's Manual for detailed information.

No account is taken of the wind force on the load. This effect, which can be substantial for loads with large surface areas, must be considered by the user. In any wind it is strongly recommended that taglines be used to control the load.

BOOM HOIST LINE is 14 parts of 7/8 inch diameter EIPS wire rope with a minimum breaking strength of 79,600 pound.

PENDANT SUSPENSION LINE is 4 parts of 1.375 inch diameter EEIPS wire rope with a minimum breaking strength of 211,000 pound.

JIB BACKSTAY LINE AND FRONTSTAY LINES are 2 parts of 0.875 inch diameter wire rope with a minimum breaking strength of 69,200 pound.

WHIP LINE – 1.125 inch diameter EIPS wire rope with a minimum breaking strength of 130,000 pound or

ALTERNATE WHIP LINE (ROTATION RESISTANT) – 1.125 inch diameter BRIDON ENDURANCE DYFORM 34LR Grade 2160 wire rope with a minimum breaking strength of 167,200 pound.

**ERECTION**

Erection „OVER THE END“ is with the boom over the idler end with idler tumblers blocked (See operator's manual for blocking instructions). Erection „OVER THE SIDE“ is with the boom 90° to the sideframes and with the side frames extended. Blocks, slings and other load carrying devices must be on the ground during erection.

LOAD HOISTING INFORMATION - 1.125 inch diameter EIPS wire rope			
MAXIMUM LIFTING CAPACITY - LBS.	MINIMUM PARTS OF LINE	MAXIMUM HOISTING DISTANCE - FT	
		MAIN (FRONT)	AUX. (REAR)
32,000	1	1,312	1,312

LOAD HOISTING INFORMATION (ROTATION RESISTANT LOAD LINE)			
1.125 inch diameter BRIDON ENDURANCE DYFORM 34LR Grade 2160 wire rope			
MAXIMUM LIFTING CAPACITY - LBS.	MINIMUM PARTS OF LINE	MAXIMUM HOISTING DISTANCE - FEET	
		MAIN (FRONT)	AUX. (REAR)
32,000	1	1,312	1,312

77SI HAMMERHEAD BOOM COMPOSITION CHART							
BOOM LENGTH (METERS)	BOOM LENGTH (FEET)	BOOM SECTIONS					
		9.1 M 30' 77SI INNER	3.0 M 10' 77S CENTER	6.1 M 20' 77S CENTER	15.2 M 50' 77S CENTER	5.9 M 19.5' 77HL OUTER	0 M 0' HAMMER HEAD
15.2 M	50	1	0	0	0	1	1
18.3 M	60	1	1	0	0	1	1
21.3 M	70	1	1	0	1	0	1
24.4 M	80	1	1	1	0	1	1
27.4 M	90	1	0	2	0	1	1
30.5 M	100	1	0	0	1	1	1
33.5 M	110	1	1	0	1	1	1
36.6 M	120	1	0	1	1	1	1
39.6 M	130	1	1	1	1	1	1
42.7 M	140	1	0	2	1	1	1
45.7 M	150	1	0	0	2	1	1
48.8 M	160	1	1	0	2	1	1
51.8 M	170	1	0	1	2	1	1
54.9 M	180	1	1	1	2	1	1
57.9 M	190	1	0	2	2	1	1
61.0 M	200	1	0	0	3	1	1
64.0 M	210	1	1	0	3	1	1
67.1 M	220	1	0	1	3	1	1
70.1 M	230	1	1	1	3	1	1
73.2 M	240	1	0	2	3	1	1

77SI HAMMERHEAD BOOM MAXIMUM BOOM & JIB SELF-ERECTION DATA				
	OVER THE END		OVER THE SIDE	
	BOOM LENGTH (FEET)	JIB LENGTH (FEET)	BOOM LENGTH (FEET)	JIB LENGTH (FEET)
#16HL JIB	240	0	220	0
	230	0	210	40
	220	80	200	80

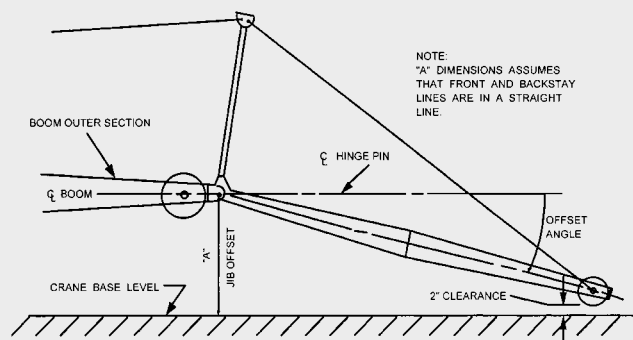

#16HL JIB COMPOSITION CHART								
JIB LENGTH (FEET)	20' INNER	10' CENTER	20' CENTER	20' OUTER	EFF. JIB WEIGHT (POUNDS)	JIB OFFSET "A" IN FEET		
						5°	15°	25°
40	1	0	0	1	1,500	4'-10"	10'- 2"	15'- 1"
50	1	1	0	1	2,050	5'- 8"	12'- 1"	18'- 3"
60	1	0	1	1	2,600	6'- 6"	13'-10"	21'- 2"
70	1	1	1	1	3,150	7'- 1"	15'-10"	24'- 4"
80	1	0	2	1	3,700	7'- 9"	17'- 8"	27'- 4"

**RANGE DIAGRAM, 77SI OFFSET TIP BOOM, #16HL JIB**

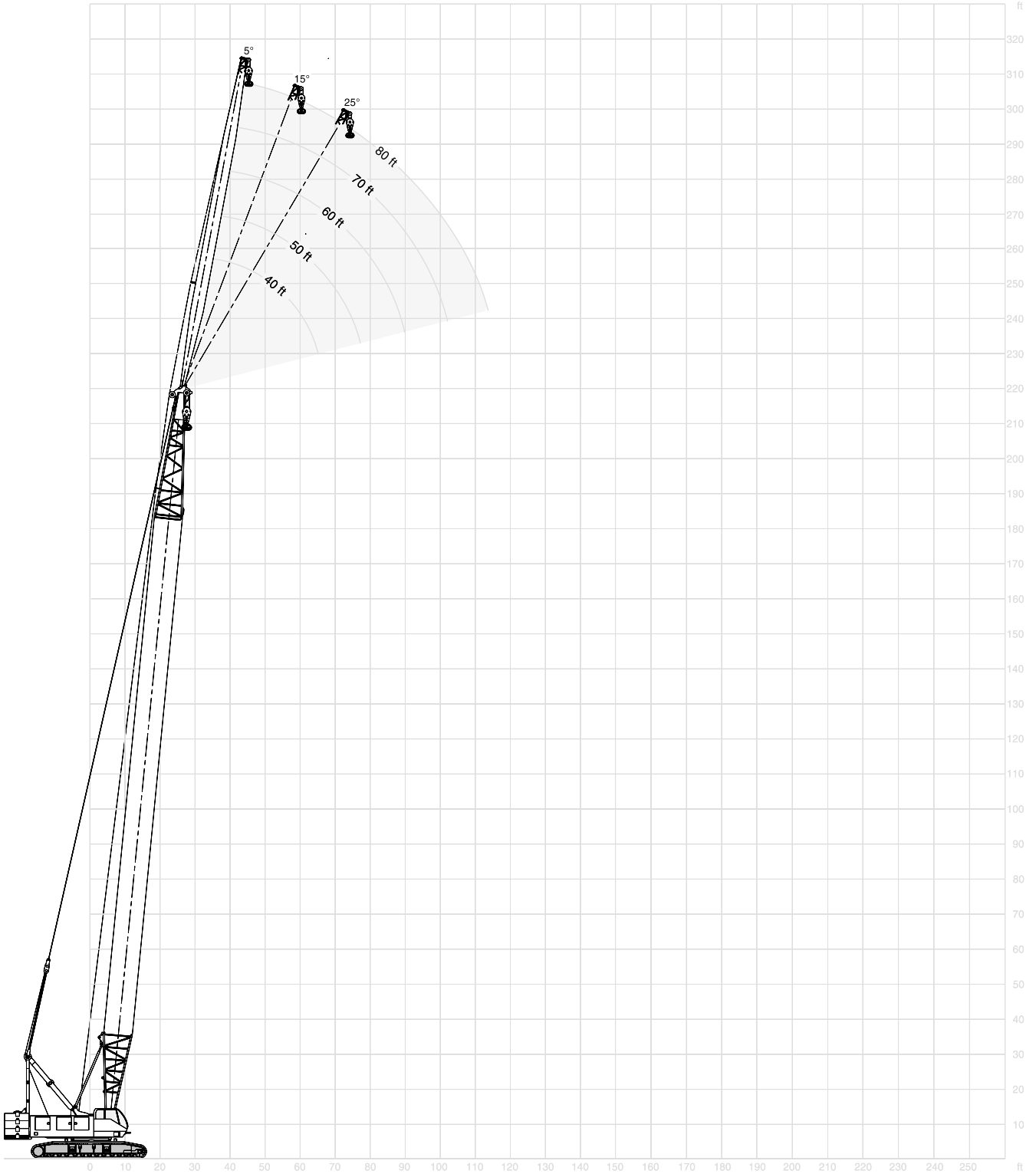

**WITH 77SI OFFSET TIP BOOM AND 102,000 POUND UPPER COUNTERWEIGHT  
#16HL JIB**

102,000 lb

360°

ANSI B 30.5

**40' (12.2 m) Jib length**

Boom length	Jib Radius (Feet)	5.0 Deg offset		15.0 Deg offset		25.0 Deg offset	
		Boom Angle	Rating (Pounds)	Boom Angle	Rating (Pounds)	Boom Angle	Rating (Pounds)
	31	80.6	32,000*	-	-	-	-
	35	78.9	32,000*	-	-	-	-
	40	76.9	32,000*	79.6	32,000*	-	-
	50	72.6	32,000*	75.3	32,000*	77.8	31,510*
<b>100'</b> <b>(30.5 m)</b>	60	68.3	32,000*	71.0	32,000*	73.4	28,280*
	70	63.8	32,000*	66.4	31,740*	68.8	25,680*
	80	59.2	32,000*	61.7	28,780*	64.0	23,630*
	90	54.2	30,280*	56.8	26,380*	59.0	21,980*
	100	49.0	27,480*	51.4	24,450*	53.5	20,650*

	32	80.8	32,000*	-	-	-	-
	35	79.7	32,000*	-	-	-	-
	40	77.7	32,000*	80.3	32,000*	-	-
	50	73.8	32,000*	76.3	32,000*	78.7	32,000*
<b>110'</b> <b>(33.5 m)</b>	60	69.8	32,000*	72.3	32,000*	74.6	28,980*
	70	65.7	32,000*	68.1	32,000*	70.4	26,500*
	80	61.4	32,000*	63.8	30,030*	66.0	24,370*
	90	57.0	31,470	59.3	27,580*	61.4	22,710*
	100	52.2	27,310	54.6	25,450*	56.6	21,280*
	110	47.2	23,980	49.5	23,790*	51.4	20,120*

	34	80.7	32,000*	-	-	-	-
	35	80.3	32,000*	-	-	-	-
	40	78.5	32,000*	80.9	32,000*	-	-
	50	74.9	32,000*	77.2	32,000*	79.4	32,000*
<b>120'</b> <b>(36.6 m)</b>	60	71.1	32,000*	73.5	32,000*	75.6	29,690*
	70	67.3	32,000*	69.6	32,000*	71.7	27,140*
	80	63.4	32,000*	65.6	31,170*	67.7	25,050*
	90	59.3	31,090	61.5	28,640*	63.5	23,330*
	100	55.0	26,920	57.2	26,480*	59.1	21,910*
	110	50.4	23,590	52.6	23,590	54.5	20,730*
	120	45.6	20,860	47.7	20,870	49.4	19,770*

	35	80.9	32,000*	-	-	-	-
	40	79.2	32,000*	-	-	-	-
	50	75.8	32,000*	78.0	32,000*	80.1	32,000*
	60	72.3	32,000*	74.5	32,000*	76.5	30,320*
<b>130'</b> <b>(39.6 m)</b>	70	68.7	32,000*	70.9	32,000*	72.9	27,880*
	80	65.0	32,000*	67.2	32,000*	69.2	25,790*
	90	61.3	30,750	63.4	29,620*	65.3	23,990*
	100	57.3	26,580	59.4	26,590	61.3	22,550*
	110	53.2	23,240	55.3	23,240	57.0	21,300*
	120	48.8	20,500	50.9	20,510	52.5	20,280*
	130	44.1	18,240	46.1	18,250	47.7	18,260

Boom length	Jib Radius (Feet)	5.0 Deg offset		15.0 Deg offset		25.0 Deg offset	
		Boom Angle	Rating (Pounds)	Boom Angle	Rating (Pounds)	Boom Angle	Rating (Pounds)
	37	80.8	32,000*	-	-	-	-
	40	79.8	32,000*	-	-	-	-
	50	76.6	32,000*	78.7	32,000*	80.7	32,000*
	60	73.3	32,000*	75.4	32,000*	77.3	30,910*
<b>140'</b> <b>(42.7 m)</b>	70	69.9	32,000*	72.0	32,000*	73.9	28,450*
	80	66.5	32,000*	68.6	32,000*	70.4	26,350*
	90	63.0	30,350	65.0	30,350	66.8	24,570*
	100	59.3	26,180	61.3	26,180	63.1	23,090*
	110	55.6	22,830	57.5	22,830	59.2	21,890*
	120	51.6	20,090	53.5	20,100	55.1	20,110
	130	47.4	17,820	49.2	17,830	50.8	17,840
	140	42.8	15,900	44.7	15,910	46.1	15,920

	38	81.0	32,000*	-	-	-	-
	40	80.3	32,000*	-	-	-	-
	50	77.3	32,000*	79.3	32,000*	-	-
	60	74.2	32,000*	76.2	32,000*	78.0	31,480*
	70	71.0	32,000*	73.0	32,000*	74.8	28,990*
	80	67.8	32,000*	69.8	32,000*	71.5	26,990*
<b>150'</b> <b>(45.7 m)</b>	90	64.5	29,960	66.4	29,960	68.2	25,210*
	100	61.1	25,770	63.0	25,780	64.7	23,680*
	110	57.6	22,430	59.5	22,440	61.1	22,430*
	120	53.9	19,690	55.8	19,700	57.4	19,710
	130	50.1	17,410	51.9	17,420	53.4	17,430
	140	46.0	15,490	47.8	15,500	49.2	15,510
	150	41.6	13,850	43.3	13,850	44.7	13,870

	40	80.8	32,000*	-	-	-	-
	50	77.9	32,000*	79.8	32,000*	-	-
	60	75.0	32,000*	76.9	32,000*	78.6	31,940*
	70	72.0	32,000*	73.9	32,000*	75.6	29,580*
	80	69.0	32,000*	70.8	32,000*	72.5	27,520*
	90	65.9	29,540	67.7	29,550	69.4	25,740*
<b>160'</b> <b>(48.8 m)</b>	100	62.7	25,360	64.5	25,360	66.1	24,220*
	110	59.4	22,010	61.2	22,020	62.8	22,030
	120	56.0	19,280	57.8	19,280	59.3	19,290
	130	52.5	16,990	54.2	17,000	55.7	17,010
	140	48.7	15,060	50.4	15,070	51.9	15,080
	150	44.8	13,420	46.4	13,420	47.8	13,440
	160	40.5	12,000	42.1	12,010	43.3	12,020

	41	81.0	32,000*	-	-	-	-
	50	78.5	32,000*	80.3	32,000*	-	-
	60	75.7	32,000*	77.5	32,000*	79.2	32,000*
	70	72.9	32,000*	74.7	32,000*	76.3	29,950*
	80	70.0	32,000*	71.8	32,000*	73.4	27,990*
	90	67.1	29,140	68.8	29,150	70.4	26,220*
<b>170'</b> <b>(51.8 m)</b>	100	64.1	24,960	65.8	24,960	67.4	24,710*
	110	61.0	21,600	62.7	21,610	64.3	21,620
	120	57.8	18,860	59.5	18,860	61.0	18,880
	130	54.5	16,570	56.2	16,580	57.6	16,590
	140	51.1	14,650	52.7	14,650	54.1	14,670
	150	47.5	13,000	49.1	13,010	50.4	13,020
	160	43.6	11,580	45.2	11,580	46.4	11,600
	170	39.5	10,340	41.0	10,350	42.1	10,360



**WITH 77SI OFFSET TIP BOOM AND 102,000 POUND UPPER COUNTERWEIGHT  
#16HL JIB**

102,000 lb

360°

ANSI B 30.5

**40' (12.2 m) Jib length**

Boom length	Jib Radius (Feet)	5.0 Deg offset Boom Angle	5.0 Deg offset Rating (Pounds)	15.0 Deg offset Boom Angle	15.0 Deg offset Rating (Pounds)	25.0 Deg offset Boom Angle	25.0 Deg offset Rating (Pounds)
	43	80.9	32,000*	-	-	-	-
	50	79.0	32,000*	80.8	32,000*	-	-
	60	76.4	32,000*	78.1	32,000*	79.7	32,000*
	70	73.7	32,000*	75.4	32,000*	77.0	30,450*
	80	71.0	32,000*	72.7	32,000*	74.2	28,440*
	90	68.2	28,770	69.9	28,780	71.4	26,700*
<b>180' (54.9 m)</b>	100	65.4	24,580	67.0	24,590	68.5	24,600
	110	62.4	21,230	64.1	21,230	65.6	21,240
	120	59.5	18,480	61.1	18,490	62.5	18,500
	130	56.4	16,190	58.0	16,200	59.4	16,210
	140	53.2	14,270	54.8	14,270	56.1	14,290
	150	49.8	12,620	51.4	12,620	52.7	12,640
	160	46.3	11,190	47.8	11,200	49.1	11,210
	170	42.6	9,950	44.0	9,960	45.2	9,970
	180	38.5	8,870	39.9	8,870	41.0	8,890

	45	80.8	32,000*	-	-	-	-
	50	79.5	32,000*	-	-	-	-
	60	77.0	32,000*	78.6	32,000*	80.2	32,000*
	70	74.4	32,000*	76.1	32,000*	77.6	30,910*
	80	71.8	32,000*	73.4	32,000*	74.9	28,870*
	90	69.2	28,350	70.8	28,360	72.3	27,220*
<b>190' (57.9 m)</b>	100	66.5	24,160	68.1	24,170	69.5	24,180
	110	63.7	20,800	65.3	20,810	66.7	20,820
	120	60.9	18,060	62.5	18,060	63.9	18,080
	130	58.0	15,770	59.6	15,770	60.9	15,780
	140	55.0	13,840	56.6	13,850	57.9	13,860
	150	51.9	12,190	53.4	12,190	54.7	12,200
	160	48.7	10,760	50.1	10,760	51.4	10,770
	170	45.2	9,510	46.7	9,520	47.8	9,530
	180	41.6	8,420	43.0	8,430	44.1	8,440
	190	37.6	7,460	39.0	7,470	40.0	7,480

	46	80.9	32,000*	-	-	-	-
	50	80.0	32,000*	-	-	-	-
	60	77.5	32,000*	79.1	32,000*	80.6	32,000*
	70	75.1	32,000*	76.6	32,000*	78.1	31,340*
	80	72.6	32,000*	74.2	32,000*	75.6	29,380*
	90	70.1	27,950	71.6	27,960	73.0	27,670*
	100	67.5	23,750	69.1	23,760	70.4	23,770
	110	64.9	20,390	66.4	20,400	67.8	20,410
<b>200' (61.0 m)</b>	120	62.2	17,650	63.8	17,650	65.1	17,660
	130	59.5	15,350	61.0	15,360	62.3	15,370
	140	56.7	13,410	58.2	13,420	59.4	13,430
	150	53.8	11,760	55.2	11,760	56.5	11,770
	160	50.7	10,320	52.2	10,330	53.4	10,340
	170	47.6	9,090	49.0	9,090	50.1	9,100
	180	44.2	7,990	45.6	8,000	46.7	8,010
	190	40.6	7,020	42.0	7,030	43.0	7,050
	200	36.8	6,170	38.1	6,180	39.0	6,200

Boom length	Jib Radius (Feet)	5.0 Deg offset Boom Angle	5.0 Deg offset Rating (Pounds)	15.0 Deg offset Boom Angle	15.0 Deg offset Rating (Pounds)	25.0 Deg offset Boom Angle	25.0 Deg offset Rating (Pounds)
	48	80.8	32,000*	-	-	-	-
	50	80.4	32,000*	-	-	-	-
	60	78.0	32,000*	79.6	32,000*	81.0	32,000*
	70	75.7	32,000*	77.2	32,000*	78.6	31,760*
	80	73.3	32,000*	74.8	32,000*	76.2	29,790*
	90	70.9	27,530	72.4	27,540	73.8	27,550
	100	68.5	23,330	69.9	23,330	71.3	23,340
	110	66.0	19,970	67.4	19,980	68.8	19,990
<b>210' (64.0 m)</b>	120	63.4	17,210	64.9	17,220	66.2	17,230
	130	60.9	14,930	62.3	14,930	63.6	14,940
	140	58.2	12,990	59.6	12,990	60.8	13,000
	150	55.4	11,330	56.8	11,330	58.0	11,350
	160	52.6	9,890	54.0	9,900	55.1	9,910
	170	49.6	8,640	51.0	8,650	52.1	8,660
	180	46.5	7,550	47.9	7,550	49.0	7,570
	190	43.3	6,570	44.6	6,580	45.6	6,590
	200	39.8	5,720	41.1	5,730	42.0	5,740
	210	36.0	4,960	37.2	4,970	38.1	4,980

	49	81.0	32,000*	-	-	-	-
	50	80.7	32,000*	-	-	-	-
	60	78.5	32,000*	80.0	32,000*	81.4	32,000*
	70	76.2	32,000*	77.7	32,000*	79.1	32,000*
	80	74.0	32,000*	75.4	32,000*	76.8	30,080*
	90	71.7	27,110	73.1	27,120	74.4	27,130
	100	69.3	22,920	70.8	22,920	72.1	22,930
	110	67.0	19,550	68.4	19,550	69.6	19,560
<b>220' (67.1 m)</b>	120	64.5	16,800	65.9	16,810	67.2	16,820
	130	62.1	14,500	63.5	14,510	64.7	14,520
	140	59.5	12,560	60.9	12,570	62.1	12,580
	150	56.9	10,900	58.3	10,910	59.5	10,920
	160	54.3	9,460	55.6	9,470	56.8	9,480
	170	51.5	8,210	52.8	8,220	53.9	8,230
	180	48.6	7,110	49.9	7,120	51.0	7,130
	190	45.6	6,150	46.9	6,150	47.9	6,170
	200	42.4	5,280	43.6	5,280	44.6	5,300
	210	39.0	4,510	40.2	4,520	41.1	4,530
	220	35.3	3,840	36.4	3,840	37.2	3,860

	51	80.9	32,000*	-	-	-	-
	60	78.9	32,000*	80.3	32,000*	81.7	32,000*
	70	76.8	32,000*	78.2	32,000*	79.5	32,000*
	80	74.6	32,000*	76.0	32,000*	77.3	30,500*
	90	72.4	26,730	73.8	26,740	75.0	26,750
	100	70.1	22,530	71.5	22,530	72.8	22,540
	110	67.9	19,160	69.2	19,160	70.5	19,170
	120	65.6	16,410	66.9	16,410	68.1	16,420
<b>230' (70.1 m)</b>	130	63.2	14,110	64.5	14,120	65.7	14,130
	140	60.8	12,170	62.1	12,170	63.3	12,180
	150	58.3	10,510	59.6	10,510	60.8	10,520
	160	55.8	9,070	57.1	9,070	58.2	9,080
	170	53.2	7,810	54.5	7,820	55.5	7,830
	180	50.5	6,710	51.7	6,720	52.8	6,730
	190	47.6	5,740	48.9	5,750	49.9	5,760
	200	44.7	4,880	45.9	4,880	46.9	4,900
	210	41.5	4,100	42.7	4,110	43.6	4,120
	220	38.2	3,420	39.4	3,420	40.2	3,440
	230	34.6	2,800	35.7	2,810	36.5	2,830

**WITH 77SI OFFSET TIP BOOM AND 102,000 POUND UPPER COUNTERWEIGHT  
#16HL JIB**

102,000 lb

360°

ANSI B 30.5

**40' (12.2 m) Jib length**

Boom length	Jib Radius (Feet)	5.0 Deg offset		15.0 Deg offset		25.0 Deg offset	
		Boom Angle	Rating (Pounds)	Boom Angle	Rating (Pounds)	Boom Angle	Rating (Pounds)
	52	81.0	32,000*	-	-	-	-
	60	79.3	32,000*	80.7	32,000*	-	-
	70	77.2	32,000*	78.6	32,000*	79.9	32,000*
	80	75.1	31,700	76.5	31,700	77.7	30,780*
	90	73.0	26,310	74.4	26,320	75.6	26,330
	100	70.9	22,110	72.2	22,110	73.4	22,120
	110	68.7	18,740	70.0	18,740	71.2	18,750
	120	66.5	15,980	67.8	15,980	69.0	15,990
<b>240' (73.2 m)</b>	130	64.2	13,680	65.5	13,680	66.7	13,700
	140	61.9	11,730	63.2	11,740	64.3	11,750
	150	59.6	10,070	60.9	10,080	62.0	10,090
	160	57.2	8,630	58.4	8,640	59.5	8,650
	170	54.7	7,370	55.9	7,380	57.0	7,390
	180	52.1	6,270	53.4	6,270	54.4	6,290
	190	49.5	5,300	50.7	5,300	51.7	5,320
	200	46.7	4,430	47.9	4,440	48.9	4,450
	210	43.8	3,660	45.0	3,670	45.9	3,680
	220	40.8	2,960	41.9	2,970	42.8	2,980
	230	37.5	2,340	38.6	2,350	39.4	2,360

Boom length	Jib Radius (Feet)	5.0 Deg offset		15.0 Deg offset		25.0 Deg offset	
		Boom Angle	Rating (Pounds)	Boom Angle	Rating (Pounds)	Boom Angle	Rating (Pounds)
	54	80.9	32,000*	-	-	-	-
	60	79.7	32,000*	-	-	-	-
	70	77.7	32,000*	79.0	32,000*	80.2	32,000*
	80	75.7	31,290	77.0	31,300	78.2	31,190*
	90	73.6	25,890	74.9	25,900	76.1	25,910
	100	71.6	21,690	72.8	21,690	74.0	21,700
	110	69.5	18,320	70.7	18,320	71.9	18,330
	120	67.3	15,560	68.6	15,560	69.7	15,570
<b>250' (76.2 m)</b>	130	65.2	13,260	66.4	13,260	67.6	13,270
	140	63.0	11,310	64.2	11,320	65.3	11,330
	150	60.7	9,650	62.0	9,650	63.1	9,660
	160	58.4	8,200	59.7	8,210	60.7	8,220
	170	56.1	6,950	57.3	6,950	58.3	6,960
	180	53.7	5,840	54.9	5,850	55.9	5,860
	190	51.2	4,860	52.3	4,860	53.3	4,880
	200	48.6	3,990	49.7	3,990	50.7	4,010
	210	45.9	3,210	47.0	3,220	47.9	3,230
	220	43.0	2,520	44.1	2,530	45.0	2,540
	230	40.0	1,890	41.1	1,900	41.9	1,920

**50' (15.2 m) Jib length**

Boom length	Jib Radius (Feet)	5.0 Deg offset		15.0 Deg offset		25.0 Deg offset	
		Boom Angle	Rating (Pounds)	Boom Angle	Rating (Pounds)	Boom Angle	Rating (Pounds)
	38	80.7	32,000*	-	-	-	-
	40	80.1	31,900*	-	-	-	-
	50	76.8	30,710*	79.5	28,230*	-	-
	60	73.6	29,560*	76.2	27,410*	78.6	25,610*
<b>130' (39.6 m)</b>	70	70.2	28,590*	72.8	26,560*	75.2	23,760*
	80	66.8	27,570*	69.4	25,940*	71.7	21,930*
	90	63.3	26,760*	65.8	25,250*	68.1	20,400*
	100	59.6	26,020*	62.1	23,580*	64.4	19,140*
	110	55.8	23,430	58.3	21,960*	60.5	18,090*
	120	51.8	20,690	54.3	20,590*	56.4	17,170*
	130	47.6	18,410	50.0	18,420	52.0	16,340*

Boom length	Jib Radius (Feet)	5.0 Deg offset		15.0 Deg offset		25.0 Deg offset	
		Boom Angle	Rating (Pounds)	Boom Angle	Rating (Pounds)	Boom Angle	Rating (Pounds)
	41	80.8	32,000*	-	-	-	-
	50	78.2	31,020*	80.6	28,330*	-	-
	60	75.2	29,930*	77.6	27,520*	79.8	25,640*
	70	72.3	29,000*	74.6	26,860*	76.8	24,550*
<b>150' (45.7 m)</b>	80	69.2	28,120*	71.6	26,210*	73.7	22,850*
	90	66.1	27,290*	68.4	25,650*	70.5	21,310*
	100	62.9	25,960	65.2	25,070*	67.3	20,000*
	110	59.7	22,610	61.9	22,620	63.9	18,900*
	120	56.3	19,880	58.5	19,880	60.4	17,980*
	130	52.7	17,590	54.9	17,600	56.8	17,160*
	140	49.0	15,670	51.1	15,680	53.0	15,690
	150	45.0	14,030	47.1	14,030	48.8	14,050

	39	80.9	32,000*	-	-	-	-
	40	80.6	32,000*	-	-	-	-
	50	77.5	30,800*	80.1	28,220*	-	-
	60	74.4	29,810*	76.9	27,440*	79.3	25,670*
<b>140' (42.7 m)</b>	70	71.3	28,740*	73.8	26,710*	76.1	24,150*
	80	68.1	27,890*	70.5	26,030*	72.8	22,350*
	90	64.8	27,100*	67.2	25,460*	69.4	20,920*
	100	61.4	26,290*	63.8	24,300*	65.9	19,600*
	110	57.9	23,020	60.2	22,720*	62.3	18,520*
	120	54.2	20,280	56.5	20,290	58.6	17,570*
	130	50.3	18,000	52.6	18,010	54.6	16,750*
	140	46.3	16,080	48.5	16,080	50.4	16,100

	42	81.0	31,940*	-	-	-	-
	50	78.7	31,170*	-	-	-	-
	60	76.0	30,160*	78.2	27,640*	80.3	25,700*
	70	73.1	29,170*	75.4	26,930*	77.5	24,960*
	80	70.3	28,340*	72.5	26,380*	74.5	23,220*
	90	67.3	27,610*	69.5	25,740*	71.5	21,690*
<b>160' (48.8 m)</b>	100	64.3	25,550	66.5	25,190*	68.5	20,400*
	110	61.2	22,200	63.4	22,210	65.3	19,340*
	120	58.1	19,450	60.2	19,460	62.1	18,340*
	130	54.8	17,170	56.9	17,180	58.7	17,190
	140	51.3	15,240	53.4	15,250	55.2	15,260
	150	47.7	13,590	49.7	13,600	51.4	13,610
	160	43.8	12,180	45.8	12,190	47.4	12,200

3

**WITH 77SI OFFSET TIP BOOM AND 102,000 POUND UPPER COUNTERWEIGHT  
#16HL JIB**

102,000 lb

360°

ANSI B 30.5

**50' (15.2 m) Jib length**

Boom length	Jib Radius (Feet)	5.0 Deg offset Boom Angle	5.0 Deg offset Rating (Pounds)	15.0 Deg offset Boom Angle	15.0 Deg offset Rating (Pounds)	25.0 Deg offset Boom Angle	25.0 Deg offset Rating (Pounds)
	44	80.8	31,790*	-	-	-	-
	50	79.3	31,190*	-	-	-	-
	60	76.6	30,230*	78.8	27,630*	80.8	25,710*
	70	73.9	29,400*	76.1	27,080*	78.1	25,240*
	80	71.2	28,560*	73.3	26,430*	75.3	23,620*
	90	68.4	27,740*	70.5	25,900*	72.5	22,120*
<b>170' (51.8 m)</b>	100	65.6	25,130	67.7	25,140	69.6	20,860*
	110	62.7	21,790	64.7	21,790	66.6	19,740*
	120	59.7	19,040	61.7	19,050	63.6	18,750*
	130	56.6	16,750	58.6	16,760	60.4	16,770
	140	53.4	14,820	55.4	14,830	57.1	14,840
	150	50.1	13,180	52.0	13,180	53.7	13,200
	160	46.5	11,750	48.5	11,760	50.0	11,770
	170	42.8	10,510	44.7	10,520	46.2	10,530

	45	81.0	31,770*	-	-	-	-
	50	79.7	31,230*	-	-	-	-
	60	77.2	30,360*	79.3	27,700*	-	-
	70	74.6	29,520*	76.7	27,140*	78.6	25,220*
	80	72.0	28,650*	74.1	26,540*	76.0	23,960*
	90	69.4	27,990*	71.4	25,950*	73.3	22,470*
<b>180' (54.9 m)</b>	100	66.7	24,760	68.7	24,770	70.5	21,210*
	110	64.0	21,400	65.9	21,410	67.7	20,100*
	120	61.1	18,660	63.1	18,670	64.9	18,680
	130	58.2	16,380	60.2	16,380	61.9	16,400
	140	55.2	14,440	57.2	14,450	58.8	14,460
	150	52.1	12,790	54.0	12,790	55.6	12,810
	160	48.9	11,360	50.7	11,360	52.3	11,380
	170	45.4	10,120	47.3	10,130	48.8	10,140
	180	41.8	9,030	43.6	9,040	45.0	9,060

	47	80.9	31,550*	-	-	-	-
	50	80.2	31,380*	-	-	-	-
	60	77.7	30,470*	79.7	27,760*	-	-
	70	75.3	29,610*	77.3	27,170*	79.1	25,220*
	80	72.8	28,830*	74.8	26,540*	76.6	24,260*
	90	70.3	28,090*	72.2	26,080*	74.0	22,820*
<b>190' (57.9 m)</b>	100	67.7	24,350	69.7	24,360	71.4	21,520*
	110	65.1	20,990	67.0	21,000	68.8	20,420*
	120	62.5	18,240	64.3	18,240	66.0	18,260
	130	59.7	15,950	61.6	15,960	63.2	15,970
	140	56.9	14,010	58.8	14,020	60.4	14,030
	150	54.0	12,360	55.8	12,360	57.4	12,380
	160	50.9	10,920	52.8	10,930	54.3	10,950
	170	47.8	9,690	49.5	9,690	51.0	9,710
	180	44.4	8,590	46.2	8,600	47.6	8,620
	190	40.8	7,620	42.5	7,630	43.9	7,650

Boom length	Jib Radius (Feet)	5.0 Deg offset Boom Angle	5.0 Deg offset Rating (Pounds)	15.0 Deg offset Boom Angle	15.0 Deg offset Rating (Pounds)	25.0 Deg offset Boom Angle	25.0 Deg offset Rating (Pounds)
	49	80.8	31,430*	-	-	-	-
	50	80.6	31,320*	-	-	-	-
	60	78.2	30,580*	80.1	27,800*	-	-
	70	75.9	29,760*	77.8	27,210*	79.6	25,200*
	80	73.5	29,010*	75.4	26,650*	77.1	24,550*
	90	71.1	28,130	73.0	26,090*	74.7	23,100*
	100	68.7	23,930	70.5	23,940	72.2	21,810*
	110	66.2	20,570	68.0	20,580	69.7	20,590
<b>200' (61.0 m)</b>	120	63.6	17,820	65.5	17,830	67.1	17,840
	130	61.0	15,530	62.9	15,530	64.5	15,550
	140	58.4	13,600	60.2	13,600	61.7	13,620
	150	55.6	11,940	57.4	11,950	58.9	11,960
	160	52.8	10,500	54.5	10,510	56.0	10,530
	170	49.8	9,250	51.6	9,260	53.0	9,270
	180	46.7	8,160	48.4	8,160	49.8	8,180
	190	43.5	7,190	45.1	7,200	46.4	7,220
	200	40.0	6,340	41.6	6,350	42.8	6,370

	50	80.9	31,350*	-	-	-	-
	60	78.7	30,550*	80.5	27,740*	-	-
	70	76.4	29,800*	78.3	27,230*	80.0	25,170*
	80	74.2	29,040*	76.0	26,620*	77.7	24,770*
	90	71.9	27,710	73.7	26,200*	75.3	23,470*
	100	69.5	23,510	71.3	23,520	72.9	22,180*
	110	67.1	20,150	68.9	20,150	70.5	20,170
	120	64.7	17,400	66.5	17,410	68.1	17,420
<b>210' (64.0 m)</b>	130	62.3	15,100	64.0	15,110	65.6	15,120
	140	59.7	13,160	61.5	13,170	63.0	13,180
	150	57.1	11,500	58.9	11,510	60.3	11,520
	160	54.5	10,060	56.2	10,070	57.6	10,090
	170	51.7	8,820	53.4	8,830	54.8	8,840
	180	48.8	7,720	50.4	7,730	51.8	7,740
	190	45.8	6,750	47.4	6,750	48.7	6,770
	200	42.6	5,890	44.2	5,890	45.4	5,910
	210	39.1	5,120	40.7	5,130	41.8	5,150

	52	80.8	31,140*	-	-	-	-
	60	79.1	30,600*	80.9	27,680*	-	-
	70	76.9	29,800*	78.7	27,140*	80.4	25,100*
	80	74.8	29,070*	76.5	26,710*	78.1	24,800*
	90	72.6	27,290	74.3	26,190*	75.9	23,730*
	100	70.3	23,100	72.0	23,110	73.6	22,420*
	110	68.0	19,730	69.8	19,730	71.3	19,750
	120	65.7	16,980	67.4	16,980	69.0	17,000
<b>220' (67.1 m)</b>	130	63.4	14,680	65.1	14,690	66.6	14,700
	140	61.0	12,740	62.6	12,740	64.1	12,760
	150	58.5	11,080	60.2	11,080	61.6	11,100
	160	56.0	9,640	57.6	9,640	59.0	9,660
	170	53.4	8,380	55.0	8,390	56.3	8,400
	180	50.6	7,290	52.2	7,300	53.6	7,310
	190	47.8	6,310	49.4	6,320	50.7	6,330
	200	44.8	5,450	46.4	5,460	47.6	5,470
	210	41.7	4,680	43.2	4,690	44.4	4,700
	220	38.4	4,000	39.9	4,010	40.9	4,020

**WITH 77SI OFFSET TIP BOOM AND 102,000 POUND UPPER COUNTERWEIGHT  
#16HL JIB**

102,000 lb

360°

ANSI B 30.5

**50' (15.2 m) Jib length**

Boom length	Jib Radius (Feet)	5.0 Deg offset		15.0 Deg offset		25.0 Deg offset	
		Boom Angle	Rating (Pounds)	Boom Angle	Rating (Pounds)	Boom Angle	Rating (Pounds)
	53	81.0	31,080*	-	-	-	-
	60	79.5	30,600*	-	-	-	-
	70	77.4	29,850*	79.1	27,190*	80.7	24,980*
	80	75.3	29,110*	77.0	26,710*	78.6	24,700*
	90	73.2	26,910	74.9	26,190*	76.4	23,990*
	100	71.0	22,710	72.7	22,720	74.2	22,730
	110	68.9	19,340	70.5	19,340	72.0	19,360
	120	66.7	16,580	68.3	16,580	69.8	16,600
<b>230' (70.1 m)</b>	130	64.4	14,280	66.0	14,290	67.5	14,300
	140	62.1	12,340	63.7	12,350	65.2	12,360
	150	59.8	10,680	61.4	10,690	62.8	10,700
	160	57.3	9,240	58.9	9,250	60.3	9,260
	170	54.9	7,980	56.4	7,990	57.8	8,000
	180	52.3	6,880	53.9	6,890	55.2	6,900
	190	49.7	5,910	51.2	5,920	52.5	5,930
	200	46.9	5,040	48.4	5,050	49.6	5,070
	210	44.0	4,270	45.5	4,280	46.6	4,290
	220	40.9	3,570	42.4	3,580	43.5	3,600
	230	37.6	2,960	39.1	2,970	40.1	2,990

Boom length	Jib Radius (Feet)	5.0 Deg offset		15.0 Deg offset		25.0 Deg offset	
		Boom Angle	Rating (Pounds)	Boom Angle	Rating (Pounds)	Boom Angle	Rating (Pounds)
	56	81.0	30,720*	-	-	-	-
	60	80.2	30,390*	-	-	-	-
	70	78.3	29,780*	79.9	27,030*	-	-
	80	76.3	29,170*	77.9	26,550*	79.4	24,540*
	90	74.3	26,080	75.9	26,080	77.4	24,260*
	100	72.4	21,870	73.9	21,880	75.3	21,890
	110	70.3	18,500	71.9	18,500	73.3	18,520
	120	68.3	15,740	69.8	15,740	71.2	15,750
<b>250' (76.2 m)</b>	130	66.2	13,440	67.8	13,440	69.1	13,450
	140	64.1	11,490	65.6	11,490	67.0	11,510
	150	62.0	9,820	63.5	9,830	64.8	9,840
	160	59.8	8,380	61.3	8,390	62.6	8,400
	170	57.5	7,120	59.0	7,130	60.3	7,140
	180	55.2	6,010	56.7	6,020	57.9	6,030
	190	52.8	5,040	54.3	5,040	55.5	5,060
	200	50.4	4,160	51.8	4,170	53.0	4,190
	210	47.9	3,390	49.3	3,390	50.4	3,410
	220	45.2	2,680	46.6	2,690	47.7	2,710
	230	42.4	2,060	43.8	2,070	44.8	2,090

	55	80.9	30,840*	-	-	-	-
	60	79.9	30,530*	-	-	-	-
	70	77.9	29,880*	79.5	27,100*	-	-
	80	75.8	29,190*	77.5	26,690*	79.0	24,610*
	90	73.8	26,490	75.4	26,250*	76.9	24,230*
	100	71.7	22,290	73.3	22,300	74.8	22,310
	110	69.6	18,920	71.2	18,920	72.7	18,940
	120	67.5	16,160	69.1	16,160	70.5	16,170
<b>240' (73.2 m)</b>	130	65.3	13,860	66.9	13,860	68.3	13,880
	140	63.1	11,910	64.7	11,920	66.1	11,930
	150	60.9	10,250	62.5	10,250	63.8	10,270
	160	58.6	8,800	60.1	8,810	61.5	8,830
	170	56.3	7,550	57.8	7,550	59.1	7,570
	180	53.8	6,440	55.3	6,450	56.6	6,460
	190	51.3	5,470	52.8	5,470	54.1	5,490
	200	48.7	4,600	50.2	4,600	51.4	4,620
	210	46.0	3,820	47.5	3,830	48.6	3,850
	220	43.2	3,130	44.6	3,140	45.7	3,160
	230	40.2	2,500	41.6	2,510	42.6	2,530
	240	37.0	1,940	38.3	1,950	39.3	1,970

**60' (18.3 m) Jib length**

Boom length	Jib Radius (Feet)	5.0 Deg offset		15.0 Deg offset		25.0 Deg offset	
		Boom Angle	Rating (Pounds)	Boom Angle	Rating (Pounds)	Boom Angle	Rating (Pounds)
	43	80.9	28,920*	-	-	-	-
	50	79.0	28,190*	-	-	-	-
	60	76.2	27,190*	78.9	24,740*	-	-
	70	73.4	26,160*	76.1	24,040*	78.6	21,560*
<b>150' (45.7 m)</b>	80	70.5	25,280*	73.2	23,380*	75.7	20,000*
	90	67.6	24,480*	70.2	22,750*	72.7	18,670*
	100	64.6	23,790*	67.2	21,830*	69.6	17,500*
	110	61.5	22,780	64.1	20,370*	66.5	16,520*
	120	58.3	20,040	60.9	19,080*	63.2	15,660*
	130	55.0	17,760	57.6	17,770	59.8	14,880*
	140	51.6	15,830	54.1	15,840	56.3	14,230*
	150	47.9	14,180	50.4	14,190	52.5	13,700*

Boom length	Jib Radius (Feet)	5.0 Deg offset		15.0 Deg offset		25.0 Deg offset		
		Boom Angle	Rating (Pounds)	Boom Angle	Rating (Pounds)	Boom Angle	Rating (Pounds)	
	45	80.8	28,710*	-	-	-	-	
	50	79.5	28,220*	-	-	-	-	
	60	76.8	27,220*	79.4	24,690*	-	-	
	70	74.1	26,330*	76.7	24,110*	79.2	21,790*	
	80	71.4	25,470*	74.0	23,480*	76.4	20,320*	
	90	68.6	24,710*	71.2	22,890*	73.5	18,950*	
<b>160' (48.8 m)</b>	100	65.8	24,020*	68.3	22,290*	70.6	17,790*	
	110	62.9	22,370	65.4	20,920*	67.7	16,820*	
	120	59.9	19,620	62.4	19,630	64.6	15,980*	
	130	56.8	17,330	59.3	17,340	61.4	15,170*	
	140	53.6	15,410	56.0	15,420	58.1	14,540*	
	150	50.3	13,760	52.7	13,770	54.7	13,780	
		160	46.7	12,330	49.1	12,340	51.0	12,360



**WITH 77SI OFFSET TIP BOOM AND 102,000 POUND UPPER COUNTERWEIGHT  
#16HL JIB**

102,000 lb

360°

ANSI B 30.5

**60' (18.3 m) Jib length**

Boom length	Jib Radius (Feet)	5.0 Deg offset Boom Angle	5.0 Deg offset Rating (Pounds)	15.0 Deg offset Boom Angle	15.0 Deg offset Rating (Pounds)	25.0 Deg offset Boom Angle	25.0 Deg offset Rating (Pounds)
	46	81.0	28,710*	-	-	-	-
	50	79.9	28,370*	-	-	-	-
	60	77.4	27,410*	79.9	24,820*	-	-
	70	74.8	26,500*	77.3	24,100*	79.6	22,130*
	80	72.2	25,670*	74.7	23,590*	77.0	20,560*
	90	69.6	24,880*	72.0	22,940*	74.3	19,210*
<b>170' (51.8 m)</b>	100	66.9	24,210*	69.3	22,410*	71.6	18,150*
	110	64.2	21,950	66.6	21,450*	68.8	17,160*
	120	61.4	19,210	63.7	19,220	65.9	16,270*
	130	58.5	16,920	60.8	16,930	62.9	15,510*
	140	55.5	14,990	57.8	15,000	59.8	14,810*
	150	52.3	13,340	54.6	13,340	56.6	13,360
	160	49.1	11,910	51.3	11,910	53.3	11,930
	170	45.6	10,670	47.9	10,680	49.7	10,700

	48	80.8	28,530*	-	-	-	-
	50	80.4	28,420*	-	-	-	-
	60	77.9	27,470*	80.3	24,840*	-	-
	70	75.5	26,670*	77.9	24,210*	80.1	22,280*
	80	73.0	25,850*	75.4	23,600*	77.6	20,810*
	90	70.5	25,060*	72.8	23,080*	75.0	19,570*
<b>180' (54.9 m)</b>	100	67.9	24,410*	70.3	22,540*	72.4	18,400*
	110	65.3	21,570	67.6	21,580	69.7	17,400*
	120	62.7	18,830	64.9	18,830	67.0	16,570*
	130	59.9	16,540	62.2	16,550	64.2	15,750*
	140	57.1	14,600	59.3	14,610	61.3	14,630
	150	54.2	12,950	56.4	12,950	58.3	12,970
	160	51.1	11,520	53.3	11,530	55.2	11,550
	170	48.0	10,280	50.1	10,280	51.9	10,300
	180	44.6	9,180	46.7	9,190	48.4	9,210

	49	81.0	28,420*	-	-	-	-
	50	80.8	28,350*	-	-	-	-
	60	78.4	27,480*	80.7	24,760*	-	-
	70	76.1	26,720*	78.4	24,200*	80.5	22,240*
	80	73.7	25,940*	76.0	23,700*	78.1	21,050*
	90	71.3	25,200*	73.6	23,090*	75.6	19,790*
<b>190' (57.9 m)</b>	100	68.9	24,520	71.1	22,630*	73.2	18,670*
	110	66.4	21,160	68.6	21,170	70.6	17,700*
	120	63.8	18,400	66.0	18,410	68.0	16,790*
	130	61.2	16,120	63.4	16,130	65.4	16,000*
	140	58.6	14,180	60.7	14,180	62.7	14,200
	150	55.8	12,520	58.0	12,530	59.8	12,540
	160	53.0	11,090	55.1	11,100	56.9	11,120
	170	50.0	9,840	52.1	9,850	53.9	9,870
	180	46.9	8,750	49.0	8,750	50.7	8,770
	190	43.7	7,780	45.7	7,790	47.3	7,810

Boom length	Jib Radius (Feet)	5.0 Deg offset Boom Angle	5.0 Deg offset Rating (Pounds)	15.0 Deg offset Boom Angle	15.0 Deg offset Rating (Pounds)	25.0 Deg offset Boom Angle	25.0 Deg offset Rating (Pounds)
	51	80.9	28,250*	-	-	-	-
	60	78.9	27,540*	-	-	-	-
	70	76.6	26,750*	78.8	24,200*	80.9	22,160*
	80	74.4	26,060*	76.5	23,690*	78.6	21,350*
	90	72.0	25,320*	74.2	23,160*	76.2	20,030*
	100	69.7	24,110	71.9	22,720*	73.9	18,950*
<b>200' (61.0 m)</b>	110	67.3	20,740	69.5	20,750	71.4	17,890*
	120	64.9	17,990	67.0	18,000	69.0	17,080*
	130	62.5	15,690	64.6	15,700	66.4	15,720
	140	59.9	13,760	62.0	13,770	63.9	13,780
	150	57.3	12,100	59.4	12,110	61.2	12,130
	160	54.6	10,660	56.7	10,670	58.5	10,690
	170	51.9	9,420	53.9	9,430	55.6	9,450
	180	49.0	8,320	51.0	8,330	52.6	8,350
	190	45.9	7,350	47.9	7,360	49.5	7,370
	200	42.7	6,500	44.7	6,510	46.2	6,530

	53	80.8	28,110*	-	-	-	-
	60	79.3	27,580*	-	-	-	-
	70	77.1	26,900*	79.2	24,200*	-	-
	80	74.9	26,160*	77.0	23,670*	79.0	21,580*
	90	72.7	25,440*	74.8	23,200*	76.8	20,280*
	100	70.5	23,690	72.6	22,740*	74.5	19,130*
	110	68.2	20,320	70.3	20,320	72.2	18,220*
	120	65.9	17,570	68.0	17,580	69.8	17,270*
<b>210' (64.0 m)</b>	130	63.6	15,270	65.6	15,280	67.4	15,290
	140	61.2	13,330	63.2	13,340	65.0	13,350
	150	58.7	11,670	60.7	11,670	62.4	11,690
	160	56.1	10,240	58.1	10,250	59.9	10,260
	170	53.5	8,980	55.5	8,990	57.2	9,010
	180	50.8	7,880	52.8	7,890	54.4	7,910
	190	48.0	6,910	49.9	6,920	51.5	6,940
	200	45.0	6,050	46.9	6,060	48.4	6,080
	210	41.9	5,280	43.7	5,290	45.2	5,310

	54	80.9	27,970*	-	-	-	-
	60	79.7	27,630*	-	-	-	-
	70	77.6	26,930*	79.6	24,190*	-	-
	80	75.5	26,250*	77.5	23,760*	79.4	21,710*
	90	73.4	25,540*	75.4	23,270*	77.3	20,450*
	100	71.2	23,270	73.2	22,810*	75.1	19,380*
	110	69.0	19,900	71.0	19,900	72.9	18,380*
	120	66.8	17,150	68.8	17,150	70.6	17,170
<b>220' (67.1 m)</b>	130	64.6	14,850	66.5	14,860	68.3	14,870
	140	62.3	12,900	64.2	12,910	66.0	12,930
	150	59.9	11,240	61.9	11,250	63.6	11,260
	160	57.5	9,800	59.4	9,810	61.1	9,820
	170	55.0	8,550	56.9	8,560	58.6	8,580
	180	52.5	7,450	54.4	7,460	56.0	7,470
	190	49.8	6,480	51.7	6,490	53.2	6,500
	200	47.1	5,610	48.9	5,620	50.4	5,640
	210	44.2	4,840	46.0	4,850	47.4	4,870
	220	41.1	4,140	42.9	4,150	44.2	4,170

**WITH 77SI OFFSET TIP BOOM AND 102,000 POUND UPPER COUNTERWEIGHT  
#16HL JIB**

102,000 lb

360°

ANSI B 30.5

**60' (18.3 m) Jib length**

Boom length	Jib Radius (Feet)	5.0 Deg offset		15.0 Deg offset		25.0 Deg offset	
		Boom Angle	Rating (Pounds)	Boom Angle	Rating (Pounds)	Boom Angle	Rating (Pounds)
	56	80.8	27,840*	-	-	-	-
	60	80.0	27,570*	-	-	-	-
	70	78.0	26,840*	80.0	24,130*	-	-
	80	76.0	26,230*	78.0	23,660*	79.8	21,720*
	90	74.0	25,540*	75.9	23,230*	77.7	20,700*
	100	71.9	22,880	73.8	22,800*	75.6	19,610*
	110	69.8	19,510	71.7	19,510	73.5	18,610*
	120	67.7	16,760	69.6	16,760	71.3	16,780
<b>230' (70.1 m)</b>	130	65.5	14,460	67.4	14,460	69.1	14,480
	140	63.3	12,510	65.2	12,520	66.9	12,530
	150	61.1	10,850	62.9	10,850	64.6	10,870
	160	58.8	9,400	60.6	9,410	62.3	9,430
	170	56.4	8,150	58.3	8,150	59.9	8,170
	180	54.0	7,050	55.8	7,060	57.4	7,070
	190	51.5	6,070	53.3	6,080	54.8	6,090
	200	48.9	5,200	50.7	5,210	52.1	5,220
	210	46.2	4,430	47.9	4,440	49.4	4,460
	220	43.3	3,730	45.1	3,740	46.4	3,760
230	40.3	3,100	42.0	3,110	43.3	3,140	

Boom length	Jib Radius (Feet)	5.0 Deg offset		15.0 Deg offset		25.0 Deg offset	
		Boom Angle	Rating (Pounds)	Boom Angle	Rating (Pounds)	Boom Angle	Rating (Pounds)
	59	80.9	27,460*	-	-	-	-
	60	80.7	27,450*	-	-	-	-
	70	78.8	26,780*	80.7	23,960*	-	-
	80	76.9	26,180*	78.8	23,590*	80.5	21,510*
	90	75.0	25,570*	76.9	23,140*	78.6	21,100*
	100	73.1	22,040	74.9	22,050	76.6	20,000*
	110	71.2	18,670	73.0	18,670	74.6	18,690
	120	69.2	15,900	71.0	15,910	72.6	15,930
<b>250' (76.2 m)</b>	130	67.2	13,600	69.0	13,610	70.6	13,630
	140	65.2	11,660	66.9	11,660	68.5	11,680
	150	63.1	9,990	64.9	10,000	66.4	10,010
	160	61.0	8,550	62.8	8,550	64.3	8,570
	170	58.9	7,280	60.6	7,290	62.1	7,310
	180	56.7	6,170	58.4	6,180	59.9	6,200
	190	54.4	5,200	56.1	5,210	57.6	5,220
	200	52.1	4,320	53.8	4,330	55.2	4,350
	210	49.7	3,540	51.3	3,550	52.7	3,570
	220	47.2	2,850	48.8	2,860	50.2	2,870
230	44.6	2,210	46.2	2,220	47.5	2,240	

	57	81.0	27,710*	-	-	-	-
	60	80.4	27,520*	-	-	-	-
	70	78.4	26,860*	80.3	24,120*	-	-
	80	76.5	26,200*	78.4	23,660*	80.2	21,650*
	90	74.5	25,590*	76.4	23,190*	78.2	20,910*
	100	72.5	22,460	74.4	22,470	76.1	19,810*
	110	70.5	19,090	72.4	19,090	74.1	18,820*
	120	68.5	16,330	70.3	16,330	72.0	16,350
<b>240' (73.2 m)</b>	130	66.4	14,030	68.2	14,030	69.9	14,050
	140	64.3	12,080	66.1	12,090	67.8	12,100
	150	62.1	10,410	63.9	10,420	65.6	10,440
	160	59.9	8,970	61.7	8,980	63.3	8,990
	170	57.7	7,720	59.5	7,730	61.0	7,740
	180	55.4	6,610	57.2	6,620	58.7	6,640
	190	53.0	5,630	54.8	5,630	56.3	5,650
	200	50.6	4,760	52.3	4,770	53.7	4,790
	210	48.0	3,990	49.7	4,000	51.1	4,010
	220	45.4	3,280	47.0	3,290	48.4	3,310
230	42.6	2,660	44.2	2,670	45.5	2,690	
240	39.6	2,100	41.2	2,110	42.5	2,130	

**70' (21.3 m) Jib length**

Boom length	Jib Radius (Feet)	5.0 Deg offset		15.0 Deg offset		25.0 Deg offset	
		Boom Angle	Rating (Pounds)	Boom Angle	Rating (Pounds)	Boom Angle	Rating (Pounds)
	50	81.0	21,370*	-	-	-	-
	60	78.6	20,590*	-	-	-	-
	70	76.3	19,880*	78.9	17,820*	-	-
	80	73.9	19,250*	76.6	17,310*	79.1	15,880*
	90	71.5	18,560*	74.1	16,840*	76.6	15,420*
	100	69.1	18,010*	71.7	16,440*	74.1	14,990*
<b>180' (54.9 m)</b>	110	66.6	17,440*	69.2	15,960*	71.6	14,640*
	120	64.0	16,930*	66.6	15,480*	69.0	14,260*
	130	61.4	16,440*	64.0	15,000*	66.3	13,730*
	140	58.8	14,740	61.3	14,640*	63.6	13,120*
	150	56.0	13,080	58.5	13,090	60.8	12,580*
	160	53.2	11,640	55.7	11,650	57.8	11,670
	170	50.2	10,400	52.7	10,410	54.8	10,430
	180	47.1	9,310	49.5	9,320	51.6	9,340

3

**WITH 77SI OFFSET TIP BOOM AND 102,000 POUND UPPER COUNTERWEIGHT  
#16HL JIB**

102,000 lb

360°

ANSI B 30.5

**70' (21.3 m) Jib length**

Boom length	Jib Radius (Feet)	5.0 Deg offset Boom Angle	5.0 Deg offset Rating (Pounds)	15.0 Deg offset Boom Angle	15.0 Deg offset Rating (Pounds)	25.0 Deg offset Boom Angle	25.0 Deg offset Rating (Pounds)
	52	80.9	21,300*	-	-	-	-
	60	79.1	20,740*	-	-	-	-
	70	76.8	19,950*	79.4	17,910*	-	-
	80	74.5	19,320*	77.1	17,350*	79.5	15,870*
	90	72.2	18,740*	74.8	16,890*	77.2	15,440*
	100	69.9	18,130*	72.4	16,510*	74.8	15,020*
<b>190' (57.9 m)</b>	110	67.5	17,580*	70.0	16,110*	72.3	14,680*
	120	65.1	17,080*	67.6	15,600*	69.9	14,360*
	130	62.6	16,240	65.1	15,130*	67.3	13,960*
	140	60.1	14,310	62.6	14,320	64.8	13,320*
	150	57.5	12,650	59.9	12,660	62.1	12,680
	160	54.8	11,220	57.2	11,230	59.3	11,250
	170	52.1	9,970	54.4	9,980	56.5	10,000
	180	49.2	8,870	51.5	8,880	53.5	8,900
	190	46.1	7,910	48.4	7,920	50.4	7,940

	53	81.0	21,240*	-	-	-	-
	60	79.5	20,790*	-	-	-	-
	70	77.3	20,110*	79.8	17,920*	-	-
	80	75.1	19,390*	77.6	17,400*	79.9	15,860*
	90	72.9	18,830*	75.4	16,940*	77.7	15,520*
	100	70.7	18,230*	73.1	16,580*	75.4	15,120*
<b>200' (61.0 m)</b>	110	68.4	17,700*	70.8	16,130*	73.1	14,730*
	120	66.1	17,210*	68.5	15,720*	70.7	14,420*
	130	63.7	15,830	66.1	15,320*	68.3	14,100*
	140	61.3	13,900	63.7	13,910	65.8	13,550*
	150	58.9	12,240	61.2	12,240	63.3	12,260
	160	56.3	10,800	58.7	10,810	60.7	10,820
	170	53.7	9,550	56.0	9,560	58.0	9,580
	180	51.0	8,450	53.3	8,460	55.2	8,480
	190	48.2	7,480	50.4	7,490	52.3	7,510
	200	45.2	6,620	47.4	6,630	49.2	6,650

	55	80.9	21,110*	-	-	-	-
	60	79.9	20,840*	-	-	-	-
	70	77.8	20,100*	80.2	17,940*	-	-
	80	75.7	19,530*	78.0	17,440*	80.3	15,840*
	90	73.5	18,900*	75.9	17,040*	78.1	15,490*
	100	71.4	18,420*	73.7	16,630*	75.9	15,130*
	110	69.2	17,850*	71.6	16,200*	73.7	14,760*
	120	67.0	17,380*	69.3	15,860*	71.5	14,470*
<b>210' (64.0 m)</b>	130	64.8	15,410	67.1	15,400*	69.2	14,160*
	140	62.5	13,460	64.7	13,470	66.8	13,490
	150	60.1	11,800	62.4	11,810	64.4	11,830
	160	57.7	10,370	59.9	10,380	61.9	10,400
	170	55.2	9,110	57.4	9,120	59.4	9,140
	180	52.7	8,010	54.9	8,020	56.8	8,040
	190	50.0	7,040	52.2	7,050	54.0	7,070
	200	47.2	6,170	49.4	6,180	51.2	6,200
	210	44.3	5,400	46.5	5,410	48.2	5,430

Boom length	Jib Radius (Feet)	5.0 Deg offset Boom Angle	5.0 Deg offset Rating (Pounds)	15.0 Deg offset Boom Angle	15.0 Deg offset Rating (Pounds)	25.0 Deg offset Boom Angle	25.0 Deg offset Rating (Pounds)
	57	80.8	21,020*	-	-	-	-
	60	80.2	20,800*	-	-	-	-
	70	78.2	20,170*	80.5	17,880*	-	-
	80	76.2	19,590*	78.5	17,420*	80.6	15,770*
	90	74.1	18,980*	76.4	17,010*	78.6	15,500*
	100	72.1	18,500*	74.3	16,610*	76.4	15,210*
	110	70.0	17,920*	72.2	16,260*	74.3	14,820*
	120	67.8	17,290	70.1	15,920*	72.1	14,510*
<b>220' (67.1 m)</b>	130	65.7	14,990	67.9	15,000	69.9	14,200*
	140	63.5	13,040	65.7	13,050	67.7	13,070
	150	61.2	11,380	63.4	11,390	65.4	11,400
	160	58.9	9,940	61.1	9,950	63.1	9,970
	170	56.6	8,690	58.8	8,690	60.6	8,710
	180	54.2	7,580	56.3	7,590	58.2	7,610
	190	51.7	6,610	53.8	6,620	55.6	6,640
	200	49.1	5,740	51.2	5,750	52.9	5,770
	210	46.4	4,960	48.4	4,970	50.1	4,990
	220	43.5	4,270	45.5	4,280	47.2	4,300

	58	80.9	20,970*	-	-	-	-
	60	80.5	20,850*	-	-	-	-
	70	78.6	20,270*	80.8	17,900*	-	-
	80	76.6	19,650*	78.9	17,460*	81.0	15,780*
	90	74.7	19,050*	76.9	17,050*	79.0	15,520*
	100	72.7	18,540*	74.9	16,660*	76.9	15,230*
	110	70.7	18,070*	72.9	16,280*	74.9	14,910*
	120	68.6	16,890	70.8	15,970*	72.8	14,560*
<b>230' (70.1 m)</b>	130	66.5	14,590	68.7	14,590	70.7	14,240*
	140	64.4	12,650	66.6	12,660	68.5	12,670
	150	62.3	10,980	64.4	10,990	66.3	11,010
	160	60.1	9,540	62.2	9,550	64.1	9,570
	170	57.9	8,280	59.9	8,290	61.8	8,310
	180	55.5	7,180	57.6	7,190	59.4	7,210
	190	53.2	6,210	55.2	6,220	57.0	6,240
	200	50.7	5,330	52.8	5,340	54.5	5,360
	210	48.2	4,560	50.2	4,570	51.9	4,590
	220	45.5	3,860	47.5	3,870	49.1	3,890
	230	42.7	3,230	44.7	3,240	46.2	3,270

	60	80.8	20,810*	-	-	-	-
	70	79.0	20,240*	-	-	-	-
	80	77.1	19,710*	79.2	17,460*	-	-
	90	75.2	19,110*	77.3	17,080*	79.3	15,430*
	100	73.3	18,650*	75.4	16,700*	77.4	15,190*
	110	71.3	18,110*	73.4	16,300*	75.4	14,920*
	120	69.3	16,460	71.5	16,000*	73.4	14,580*
	130	67.3	14,160	69.4	14,170	71.4	14,190
<b>240' (73.2 m)</b>	140	65.3	12,220	67.4	12,220	69.3	12,240
	150	63.3	10,550	65.3	10,560	67.2	10,580
	160	61.2	9,110	63.2	9,110	65.0	9,130
	170	59.0	7,850	61.1	7,860	62.9	7,880
	180	56.8	6,740	58.8	6,750	60.6	6,770
	190	54.6	5,770	56.6	5,780	58.3	5,800
	200	52.2	4,890	54.2	4,900	55.9	4,920
	210	49.8	4,110	51.8	4,120	53.4	4,140
	220	47.3	3,420	49.3	3,430	50.9	3,450
	230	44.7	2,780	46.6	2,790	48.2	2,820
	240	42.0	2,210	43.9	2,230	45.3	2,250

**WITH 77SI OFFSET TIP BOOM AND 102,000 POUND UPPER COUNTERWEIGHT  
#16HL JIB**

102,000 lb

360°

ANSI B 30.5

**80' (24.4 m) Jib length**

Boom length	Jib Radius (Feet)	5.0 Deg offset		15.0 Deg offset		25.0 Deg offset	
		Boom Angle	Rating (Pounds)	Boom Angle	Rating (Pounds)	Boom Angle	Rating (Pounds)
	56	80.9	16,550*	-	-	-	-
	60	80.0	16,300*	-	-	-	-
	70	77.9	15,600*	80.7	13,680*	-	-
	80	75.8	15,020*	78.6	13,260*	-	-
	90	73.7	14,470*	76.4	12,760*	79.0	11,270*
	100	71.6	14,000*	74.3	12,310*	76.8	10,920*
<b>200' (61.0 m)</b>	110	69.4	13,490*	72.1	11,870*	74.6	10,600*
	120	67.2	12,980*	69.8	11,470*	72.3	10,340*
	130	64.9	12,480*	67.6	11,080*	70.0	10,060*
	140	62.6	12,000*	65.3	10,760*	67.6	9,860*
	150	60.3	11,600*	62.9	10,450*	65.2	9,660*
	160	57.9	10,920	60.5	10,190*	62.8	9,450*
	170	55.4	9,670	58.0	9,680	60.2	9,290*
	180	52.8	8,570	55.4	8,580	57.6	8,600
	190	50.2	7,600	52.7	7,610	54.8	7,630
	200	47.4	6,730	49.9	6,740	52.0	6,770

	57	81.0	16,490*	-	-	-	-
	60	80.4	16,280*	-	-	-	-
	70	78.4	15,710*	-	-	-	-
	80	76.3	15,130*	79.0	13,280*	-	-
	90	74.3	14,550*	76.9	12,850*	79.4	11,290*
	100	72.2	14,090*	74.8	12,350*	77.3	10,940*
	110	70.1	13,600*	72.7	11,950*	75.1	10,640*
	120	68.0	13,150*	70.6	11,560*	73.0	10,360*
<b>210' (64.0 m)</b>	130	65.9	12,640*	68.4	11,180*	70.8	10,130*
	140	63.7	12,160*	66.2	10,840*	68.5	9,900*
	150	61.4	11,750*	63.9	10,540*	66.2	9,670*
	160	59.1	10,490	61.6	10,280*	63.9	9,490*
	170	56.8	9,240	59.2	9,250	61.4	9,270
	180	54.3	8,140	56.8	8,150	58.9	8,170
	190	51.8	7,170	54.3	7,180	56.4	7,200
	200	49.2	6,300	51.6	6,310	53.7	6,330
	210	46.5	5,520	48.9	5,530	50.9	5,560

	59	80.9	16,420*	-	-	-	-
	60	80.7	16,300*	-	-	-	-
	70	78.8	15,750*	-	-	-	-
	80	76.8	15,170*	79.4	13,260*	-	-
	90	74.8	14,630*	77.4	12,880*	79.8	11,310*
	100	72.8	14,180*	75.4	12,420*	77.7	10,970*
	110	70.8	13,690*	73.3	12,010*	75.7	10,670*
	120	68.8	13,290*	71.3	11,590*	73.6	10,420*
<b>220' (67.1 m)</b>	130	66.7	12,830*	69.2	11,280*	71.5	10,160*
	140	64.6	12,350*	67.1	10,920*	69.3	9,930*
	150	62.5	11,510	64.9	10,620*	67.1	9,730*
	160	60.3	10,070	62.7	10,080	64.9	9,520*
	170	58.0	8,820	60.4	8,830	62.6	8,850
	180	55.7	7,710	58.1	7,720	60.2	7,740
	190	53.3	6,740	55.7	6,750	57.8	6,770
	200	50.9	5,860	53.2	5,880	55.2	5,900
	210	48.3	5,090	50.7	5,100	52.6	5,120
	220	45.7	4,390	48.0	4,400	49.8	4,430

Boom length	Jib Radius (Feet)	5.0 Deg offset		15.0 Deg offset		25.0 Deg offset	
		Boom Angle	Rating (Pounds)	Boom Angle	Rating (Pounds)	Boom Angle	Rating (Pounds)
	61	80.8	16,310*	-	-	-	-
	70	79.1	15,790*	-	-	-	-
	80	77.2	15,220*	79.7	13,300*	-	-
	90	75.3	14,700*	77.8	12,920*	80.1	11,330*
	100	73.4	14,200*	75.9	12,480*	78.1	10,990*
	110	71.5	13,770*	73.9	12,080*	76.2	10,670*
	120	69.5	13,340*	71.9	11,670*	74.2	10,420*
	130	67.5	12,960*	69.9	11,320*	72.1	10,180*
<b>230' (70.1 m)</b>	140	65.5	12,480*	67.9	10,920*	70.1	9,970*
	150	63.4	11,110	65.8	10,720*	67.9	9,740*
	160	61.3	9,680	63.7	9,690	65.8	9,560*
	170	59.2	8,410	61.5	8,420	63.6	8,440
	180	57.0	7,300	59.3	7,310	61.3	7,340
	190	54.7	6,330	57.0	6,340	59.0	6,360
	200	52.4	5,460	54.7	5,470	56.6	5,500
	210	50.0	4,680	52.2	4,690	54.2	4,720
	220	47.5	3,990	49.7	4,000	51.6	4,020
	230	44.9	3,350	47.1	3,370	48.9	3,390

	62	80.9	16,250*	-	-	-	-
	70	79.5	15,800*	-	-	-	-
	80	77.6	15,260*	80.0	13,270*	-	-
	90	75.8	14,760*	78.2	12,950*	80.4	11,340*
	100	73.9	14,270*	76.3	12,590*	78.5	11,010*
	110	72.1	13,840*	74.4	12,140*	76.6	10,710*
	120	70.2	13,430*	72.5	11,740*	74.7	10,470*
	130	68.3	13,050*	70.6	11,420*	72.7	10,190*
<b>240' (73.2 m)</b>	140	66.3	12,350	68.6	11,080*	70.7	9,990*
	150	64.3	10,690	66.6	10,700	68.7	9,780*
	160	62.3	9,240	64.6	9,250	66.7	9,270
	170	60.2	7,980	62.5	7,990	64.5	8,010
	180	58.1	6,880	60.4	6,890	62.4	6,910
	190	56.0	5,900	58.2	5,910	60.2	5,930
	200	53.8	5,020	56.0	5,040	57.9	5,060
	210	51.5	4,240	53.7	4,250	55.6	4,280
	220	49.1	3,540	51.3	3,550	53.1	3,580
	230	46.7	2,910	48.8	2,920	50.6	2,940
	240	44.1	2,340	46.2	2,360	47.9	2,380



**WITH 77SI OFFSET TIP BOOM AND 116,400 POUND COUNTERWEIGHT  
#16HL JIB**

108,400 lb + 8,000 lb carbody counterweight

360°

ANSI B 30.5

**40' (12.2 m) Jib length**

Boom length	Jib Radius (Feet)	5.0 Deg offset		15.0 Deg offset		25.0 Deg offset	
		Boom Angle	Rating (Pounds)	Boom Angle	Rating (Pounds)	Boom Angle	Rating (Pounds)
	31	80.6	32,000*	-	-	-	-
	35	78.9	32,000*	-	-	-	-
	40	76.9	32,000*	79.6	32,000*	-	-
	50	72.6	32,000*	75.3	32,000*	77.8	31,510*
<b>100'</b> (30.5 m)	60	68.3	32,000*	71.0	32,000*	73.4	28,280*
	70	63.8	32,000*	66.4	31,740*	68.8	25,680*
	80	59.2	32,000*	61.7	28,780*	64.0	23,630*
	90	54.2	30,280*	56.8	26,380*	59.0	21,980*
100	49.0	27,480*	51.4	24,450*	53.5	20,650*	

	32	80.8	32,000*	-	-	-	-
	35	79.7	32,000*	-	-	-	-
	40	77.7	32,000*	80.3	32,000*	-	-
	50	73.8	32,000*	76.3	32,000*	78.7	32,000*
<b>110'</b> (33.5 m)	60	69.8	32,000*	72.3	32,000*	74.6	28,980*
	70	65.7	32,000*	68.1	32,000*	70.4	26,500*
	80	61.4	32,000*	63.8	30,030*	66.0	24,370*
	90	57.0	32,000*	59.3	27,580*	61.4	22,710*
100	52.2	29,050*	54.6	25,450*	56.6	21,280*	
110	47.2	25,620	49.5	23,790*	51.4	20,120*	

	34	80.7	32,000*	-	-	-	-
	35	80.3	32,000*	-	-	-	-
	40	78.5	32,000*	80.9	32,000*	-	-
	50	74.9	32,000*	77.2	32,000*	79.4	32,000*
<b>120'</b> (36.6 m)	60	71.1	32,000*	73.5	32,000*	75.6	29,690*
	70	67.3	32,000*	69.6	32,000*	71.7	27,140*
	80	63.4	32,000*	65.6	31,170*	67.7	25,050*
	90	59.3	32,000*	61.5	28,640*	63.5	23,330*
100	55.0	28,750	57.2	26,480*	59.1	21,910*	
110	50.4	25,240	52.6	24,750*	54.5	20,730*	
120	45.6	22,360	47.7	22,370	49.4	19,770*	

	35	80.9	32,000*	-	-	-	-
	40	79.2	32,000*	-	-	-	-
	50	75.8	32,000*	78.0	32,000*	80.1	32,000*
	60	72.3	32,000*	74.5	32,000*	76.5	30,320*
<b>130'</b> (39.6 m)	70	68.7	32,000*	70.9	32,000*	72.9	27,880*
	80	65.0	32,000*	67.2	32,000*	69.2	25,790*
	90	61.3	32,000*	63.4	29,620*	65.3	23,990*
	100	57.3	28,410	59.4	27,530*	61.3	22,550*
110	53.2	24,890	55.3	24,890	57.0	21,300*	
120	48.8	22,000	50.9	22,010	52.5	20,280*	
130	44.1	19,610	46.1	19,620	47.7	19,400*	

Boom length	Jib Radius (Feet)	5.0 Deg offset		15.0 Deg offset		25.0 Deg offset	
		Boom Angle	Rating (Pounds)	Boom Angle	Rating (Pounds)	Boom Angle	Rating (Pounds)
	37	80.8	32,000*	-	-	-	-
	40	79.8	32,000*	-	-	-	-
	50	76.6	32,000*	78.7	32,000*	80.7	32,000*
	60	73.3	32,000*	75.4	32,000*	77.3	30,910*
<b>140'</b> (42.7 m)	70	69.9	32,000*	72.0	32,000*	73.9	28,450*
	80	66.5	32,000*	68.6	32,000*	70.4	26,350*
	90	63.0	32,000*	65.0	30,600*	66.8	24,570*
	100	59.3	28,010	61.3	28,010	63.1	23,090*
110	55.6	24,480	57.5	24,480	59.2	21,890*	
120	51.6	21,590	53.5	21,600	55.1	20,780*	
130	47.4	19,190	49.2	19,200	50.8	19,210	
140	42.8	17,170	44.7	17,180	46.1	17,190	

	38	81.0	32,000*	-	-	-	-
	40	80.3	32,000*	-	-	-	-
	50	77.3	32,000*	79.3	32,000*	-	-
	60	74.2	32,000*	76.2	32,000*	78.0	31,480*
	70	71.0	32,000*	73.0	32,000*	74.8	28,990*
	80	67.8	32,000*	69.8	32,000*	71.5	26,990*
<b>150'</b> (45.7 m)	90	64.5	32,000*	66.4	31,540*	68.2	25,210*
	100	61.1	27,600	63.0	27,610	64.7	23,680*
	110	57.6	24,080	59.5	24,090	61.1	22,430*
	120	53.9	21,190	55.8	21,200	57.4	21,210
130	50.1	18,790	51.9	18,800	53.4	18,810	
140	46.0	16,750	47.8	16,760	49.2	16,770	
150	41.6	15,030	43.3	15,030	44.7	15,050	

	40	80.8	32,000*	-	-	-	-
	50	77.9	32,000*	79.8	32,000*	-	-
	60	75.0	32,000*	76.9	32,000*	78.6	31,940*
	70	72.0	32,000*	73.9	32,000*	75.6	29,580*
	80	69.0	32,000*	70.8	32,000*	72.5	27,520*
	90	65.9	31,590	67.7	31,600	69.4	25,740*
<b>160'</b> (48.8 m)	100	62.7	27,190	64.5	27,190	66.1	24,220*
	110	59.4	23,650	61.2	23,660	62.8	22,980*
	120	56.0	20,770	57.8	20,770	59.3	20,780
	130	52.5	18,360	54.2	18,370	55.7	18,380
140	48.7	16,330	50.4	16,340	51.9	16,350	
150	44.8	14,600	46.4	14,600	47.8	14,620	
160	40.5	13,100	42.1	13,110	43.3	13,120	

	41	81.0	32,000*	-	-	-	-
	50	78.5	32,000*	80.3	32,000*	-	-
	60	75.7	32,000*	77.5	32,000*	79.2	32,000*
	70	72.9	32,000*	74.7	32,000*	76.3	29,950*
	80	70.0	32,000*	71.8	32,000*	73.4	27,990*
	90	67.1	31,190	68.8	31,200	70.4	26,220*
<b>170'</b> (51.8 m)	100	64.1	26,790	65.8	26,790	67.4	24,710*
	110	61.0	23,250	62.7	23,260	64.3	23,270
	120	57.8	20,360	59.5	20,360	61.0	20,380
	130	54.5	17,950	56.2	17,960	57.6	17,970
140	51.1	15,920	52.7	15,920	54.1	15,940	
150	47.5	14,180	49.1	14,190	50.4	14,200	
160	43.6	12,680	45.2	12,680	46.4	12,700	
170	39.5	11,370	41.0	11,380	42.1	11,390	

**WITH 77SI OFFSET TIP BOOM AND 116,400 POUND COUNTERWEIGHT  
#16HL JIB**

108,400 lb + 8,000 lb carbody counterweight

360°

ANSI B 30.5

**40' (12.2 m) Jib length**

Boom length	Jib Radius (Feet)	5.0 Deg offset Boom Angle	5.0 Deg offset Rating (Pounds)	15.0 Deg offset Boom Angle	15.0 Deg offset Rating (Pounds)	25.0 Deg offset Boom Angle	25.0 Deg offset Rating (Pounds)
	43	80.9	32,000*	-	-	-	-
	50	79.0	32,000*	80.8	32,000*	-	-
	60	76.4	32,000*	78.1	32,000*	79.7	32,000*
	70	73.7	32,000*	75.4	32,000*	77.0	30,450*
	80	71.0	32,000*	72.7	32,000*	74.2	28,440*
	90	68.2	30,820	69.9	30,830	71.4	26,700*
<b>180' (54.9 m)</b>	100	65.4	26,410	67.0	26,420	68.5	25,170*
	110	62.4	22,880	64.1	22,880	65.6	22,890
	120	59.5	19,980	61.1	19,990	62.5	20,000
	130	56.4	17,570	58.0	17,580	59.4	17,590
	140	53.2	15,540	54.8	15,540	56.1	15,560
	150	49.8	13,800	51.4	13,800	52.7	13,820
	160	46.3	12,290	47.8	12,300	49.1	12,310
	170	42.6	10,980	44.0	10,990	45.2	11,000
	180	38.5	9,840	39.9	9,840	41.0	9,860

	45	80.8	32,000*	-	-	-	-
	50	79.5	32,000*	-	-	-	-
	60	77.0	32,000*	78.6	32,000*	80.2	32,000*
	70	74.4	32,000*	76.1	32,000*	77.6	30,910*
	80	71.8	32,000*	73.4	32,000*	74.9	28,870*
	90	69.2	30,410	70.8	30,420	72.3	27,220*
<b>190' (57.9 m)</b>	100	66.5	25,990	68.1	26,000	69.5	25,650*
	110	63.7	22,450	65.3	22,460	66.7	22,470
	120	60.9	19,560	62.5	19,560	63.9	19,580
	130	58.0	17,150	59.6	17,150	60.9	17,160
	140	55.0	15,110	56.6	15,120	57.9	15,130
	150	51.9	13,370	53.4	13,370	54.7	13,380
	160	48.7	11,860	50.1	11,860	51.4	11,870
	170	45.2	10,540	46.7	10,550	47.8	10,560
	180	41.6	9,390	43.0	9,400	44.1	9,410
	190	37.6	8,380	39.0	8,390	40.0	8,400

	46	80.9	32,000*	-	-	-	-
	50	80.0	32,000*	-	-	-	-
	60	77.5	32,000*	79.1	32,000*	80.6	32,000*
	70	75.1	32,000*	76.6	32,000*	78.1	31,340*
	80	72.6	32,000*	74.2	32,000*	75.6	29,380*
	90	70.1	30,000	71.6	30,010	73.0	27,670*
	100	67.5	25,580	69.1	25,590	70.4	25,600
	110	64.9	22,040	66.4	22,050	67.8	22,060
<b>200' (61.0 m)</b>	120	62.2	19,150	63.8	19,150	65.1	19,160
	130	59.5	16,720	61.0	16,730	62.3	16,740
	140	56.7	14,680	58.2	14,690	59.4	14,700
	150	53.8	12,940	55.2	12,940	56.5	12,950
	160	50.7	11,430	52.2	11,440	53.4	11,450
	170	47.6	10,120	49.0	10,120	50.1	10,130
	180	44.2	8,960	45.6	8,970	46.7	8,980
	190	40.6	7,940	42.0	7,950	43.0	7,970
	200	36.8	7,040	38.1	7,050	39.0	7,070

Boom length	Jib Radius (Feet)	5.0 Deg offset Boom Angle	5.0 Deg offset Rating (Pounds)	15.0 Deg offset Boom Angle	15.0 Deg offset Rating (Pounds)	25.0 Deg offset Boom Angle	25.0 Deg offset Rating (Pounds)
	48	80.8	32,000*	-	-	-	-
	50	80.4	32,000*	-	-	-	-
	60	78.0	32,000*	79.6	32,000*	81.0	32,000*
	70	75.7	32,000*	77.2	32,000*	78.6	31,760*
	80	73.3	32,000*	74.8	32,000*	76.2	29,790*
	90	70.9	29,580	72.4	29,590	73.8	28,010*
	100	68.5	25,160	69.9	25,160	71.3	25,170
	110	66.0	21,620	67.4	21,630	68.8	21,640
<b>210' (64.0 m)</b>	120	63.4	18,710	64.9	18,720	66.2	18,730
	130	60.9	16,300	62.3	16,300	63.6	16,310
	140	58.2	14,260	59.6	14,260	60.8	14,270
	150	55.4	12,510	56.8	12,510	58.0	12,530
	160	52.6	10,990	54.0	11,000	55.1	11,010
	170	49.6	9,670	51.0	9,680	52.1	9,690
	180	46.5	8,520	47.9	8,520	49.0	8,540
	190	43.3	7,490	44.6	7,500	45.6	7,510
	200	39.8	6,590	41.1	6,600	42.0	6,610
	210	36.0	5,790	37.2	5,800	38.1	5,810

	49	81.0	32,000*	-	-	-	-
	50	80.7	32,000*	-	-	-	-
	60	78.5	32,000*	80.0	32,000*	79.1	32,000*
	70	76.2	32,000*	77.7	32,000*	76.8	30,080*
	80	74.0	32,000*	75.4	32,000*	74.4	28,440*
	90	71.7	29,170	73.1	29,180	72.1	24,750
	100	69.3	24,740	70.8	24,740	69.6	21,210
	110	67.0	21,200	68.4	21,200	67.2	18,310
<b>220' (67.1 m)</b>	120	64.5	18,290	65.9	18,300	64.7	15,890
	130	62.1	15,870	63.5	15,880	62.1	13,850
	140	59.5	13,830	60.9	13,840	59.5	12,100
	150	56.9	12,080	58.3	12,090	56.8	10,580
	160	54.3	10,560	55.6	10,570	53.9	9,260
	170	51.5	9,240	52.8	9,250	51.0	8,100
	180	48.6	8,080	49.9	8,090	47.9	7,080
	190	45.6	7,060	46.9	7,060	44.6	6,180
	200	42.4	6,160	43.6	6,160	41.1	5,360
	210	39.0	5,340	40.2	5,350	37.2	4,640
	220	35.3	4,620	36.4	4,620	-	-

	51	80.9	32,000*	-	-	-	-
	60	78.9	32,000*	80.3	32,000*	-	-
	70	76.8	32,000*	78.2	32,000*	79.5	32,000*
	80	74.6	32,000*	76.0	32,000*	77.3	30,500*
	90	72.4	28,780	73.8	28,790	75.0	28,770*
	100	70.1	24,360	71.5	24,360	72.8	24,370
	110	67.9	20,810	69.2	20,810	70.5	20,820
	120	65.6	17,900	66.9	17,900	68.1	17,910
<b>230' (70.1 m)</b>	130	63.2	15,480	64.5	15,490	65.7	15,500
	140	60.8	13,440	62.1	13,440	63.3	13,450
	150	58.3	11,690	59.6	11,690	60.8	11,700
	160	55.8	10,170	57.1	10,170	58.2	10,180
	170	53.2	8,840	54.5	8,850	55.5	8,860
	180	50.5	7,680	51.7	7,690	52.8	7,700
	190	47.6	6,650	48.9	6,660	49.9	6,670
	200	44.7	5,750	45.9	5,750	46.9	5,770
	210	41.5	4,930	42.7	4,940	43.6	4,950
	220	38.2	4,210	39.4	4,210	40.2	4,230
	230	34.6	3,550	35.7	3,560	36.5	3,580

**WITH 77SI OFFSET TIP BOOM AND 116,400 POUND COUNTERWEIGHT  
#16HL JIB**

108,400 lb + 8,000 lb carbody counterweight

360°

ANSI B 30.5

**40' (12.2 m) Jib length**

Boom length	Jib Radius (Feet)	5.0 Deg offset		15.0 Deg offset		25.0 Deg offset	
		Boom Angle	Rating (Pounds)	Boom Angle	Rating (Pounds)	Boom Angle	Rating (Pounds)
	52	81.0	32,000*	-	-	-	-
	60	79.3	32,000*	80.7	32,000*	-	-
	70	77.2	32,000*	78.6	32,000*	79.9	32,000*
	80	75.1	32,000*	76.5	32,000*	77.7	30,780*
	90	73.0	28,360	74.4	28,370	75.6	28,380
	100	70.9	23,940	72.2	23,940	73.4	23,950
	110	68.7	20,390	70.0	20,390	71.2	20,400
	120	66.5	17,480	67.8	17,480	69.0	17,490
240' (73.2 m)	130	64.2	15,050	65.5	15,050	66.7	15,070
	140	61.9	13,000	63.2	13,010	64.3	13,020
	150	59.6	11,250	60.9	11,260	62.0	11,270
	160	57.2	9,730	58.4	9,740	59.5	9,750
	170	54.7	8,410	55.9	8,420	57.0	8,430
	180	52.1	7,250	53.4	7,250	54.4	7,270
	190	49.5	6,220	50.7	6,220	51.7	6,240
	200	46.7	5,300	47.9	5,310	48.9	5,320
	210	43.8	4,480	45.0	4,490	45.9	4,500
	220	40.8	3,750	41.9	3,760	42.8	3,770
	230	37.5	3,090	38.6	3,100	39.4	3,110
	240	33.9	2,510	35.0	2,520	35.7	2,530

Boom length	Jib Radius (Feet)	5.0 Deg offset		15.0 Deg offset		25.0 Deg offset	
		Boom Angle	Rating (Pounds)	Boom Angle	Rating (Pounds)	Boom Angle	Rating (Pounds)
	54	80.9	32,000*	-	-	-	-
	60	79.7	32,000*	-	-	-	-
	70	77.7	32,000*	79.0	32,000*	80.2	32,000*
	80	75.7	32,000*	77.0	32,000*	78.2	31,190*
	90	73.6	27,950	74.9	27,960	76.1	27,970
	100	71.6	23,520	72.8	23,520	74.0	23,530
	110	69.5	19,970	70.7	19,970	71.9	19,980
	120	67.3	17,060	68.6	17,060	69.7	17,070
250' (76.2 m)	130	65.2	14,630	66.4	14,630	67.6	14,640
	140	63.0	12,580	64.2	12,590	65.3	12,600
	150	60.7	10,830	62.0	10,830	63.1	10,840
	160	58.4	9,300	59.7	9,310	60.7	9,320
	170	56.1	7,980	57.3	7,980	58.3	7,990
	180	53.7	6,810	54.9	6,820	55.9	6,830
	190	51.2	5,780	52.3	5,780	53.3	5,800
	200	48.6	4,870	49.7	4,870	50.7	4,890
	210	45.9	4,040	47.0	4,050	47.9	4,060
	220	43.0	3,310	44.1	3,320	45.0	3,330
	230	40.0	2,640	41.1	2,650	41.9	2,670
	240	36.8	2,050	37.9	2,060	38.6	2,080

**50' (15.2 m) Jib length**

Boom length	Jib Radius (Feet)	5.0 Deg offset		15.0 Deg offset		25.0 Deg offset	
		Boom Angle	Rating (Pounds)	Boom Angle	Rating (Pounds)	Boom Angle	Rating (Pounds)
	38	80.7	32,000*	-	-	-	-
	40	80.1	31,900*	-	-	-	-
	50	76.8	30,710*	79.5	28,230*	-	-
	60	73.6	29,560*	76.2	27,410*	78.6	25,610*
130' (39.6 m)	70	70.2	28,590*	72.8	26,560*	75.2	23,760*
	80	66.8	27,570*	69.4	25,940*	71.7	21,930*
	90	63.3	26,760*	65.8	25,250*	68.1	20,400*
	100	59.6	26,020*	62.1	23,580*	64.4	19,140*
	110	55.8	25,070	58.3	21,960*	60.5	18,090*
	120	51.8	22,190	54.3	20,590*	56.4	17,170*
	130	47.6	19,790	50.0	19,480*	52.0	16,340*

Boom length	Jib Radius (Feet)	5.0 Deg offset		15.0 Deg offset		25.0 Deg offset	
		Boom Angle	Rating (Pounds)	Boom Angle	Rating (Pounds)	Boom Angle	Rating (Pounds)
	41	80.8	32,000*	-	-	-	-
	50	78.2	31,020*	80.6	28,330*	-	-
	60	75.2	29,930*	77.6	27,520*	79.8	25,640*
	70	72.3	29,000*	74.6	26,860*	76.8	24,550*
150' (45.7 m)	80	69.2	28,120*	71.6	26,210*	73.7	22,850*
	90	66.1	27,290*	68.4	25,650*	70.5	21,310*
	100	62.9	26,560*	65.2	25,070*	67.3	20,000*
	110	59.7	24,260	61.9	23,410*	63.9	18,900*
	120	56.3	21,380	58.5	21,380	60.4	17,980*
	130	52.7	18,970	54.9	18,980	56.8	17,160*
	140	49.0	16,940	51.1	16,950	53.0	16,430*
	150	45.0	15,210	47.1	15,210	48.8	15,230

	39	80.9	32,000*	-	-	-	-
	40	80.6	32,000*	-	-	-	-
	50	77.5	30,800*	80.1	28,220*	-	-
	60	74.4	29,810*	76.9	27,440*	79.3	25,670*
140' (42.7 m)	70	71.3	28,740*	73.8	26,710*	76.1	24,150*
	80	68.1	27,890*	70.5	26,030*	72.8	22,350*
	90	64.8	27,100*	67.2	25,460*	69.4	20,920*
	100	61.4	26,290*	63.8	24,300*	65.9	19,600*
	110	57.9	24,660	60.2	22,720*	62.3	18,520*
	120	54.2	21,770	56.5	21,310*	58.6	17,570*
	130	50.3	19,370	52.6	19,380	54.6	16,750*
	140	46.3	17,350	48.5	17,350	50.4	16,100*

	42	81.0	31,940*	-	-	-	-
	50	78.7	31,170*	-	-	-	-
	60	76.0	30,160*	78.2	27,640*	80.3	25,700*
	70	73.1	29,170*	75.4	26,930*	77.5	24,960*
	80	70.3	28,340*	72.5	26,380*	74.5	23,220*
	90	67.3	27,610*	69.5	25,740*	71.5	21,690*
160' (48.8 m)	100	64.3	26,890*	66.5	25,190*	68.5	20,400*
	110	61.2	23,840	63.4	23,850	65.3	19,340*
	120	58.1	20,950	60.2	20,960	62.1	18,340*
	130	54.8	18,540	56.9	18,550	58.7	17,500*
	140	51.3	16,510	53.4	16,520	55.2	16,530
	150	47.7	14,770	49.7	14,780	51.4	14,790
	160	43.8	13,280	45.8	13,290	47.4	13,300

**WITH 77SI OFFSET TIP BOOM AND 116,400 POUND COUNTERWEIGHT**  
**#16HL JIB**

108,400 lb + 8,000 lb carbody counterweight

360°

ANSI B 30.5

**50' (15.2 m) Jib length**

Boom length	Jib Radius (Feet)	5.0 Deg offset		15.0 Deg offset		25.0 Deg offset	
		Boom Angle	Rating (Pounds)	Boom Angle	Rating (Pounds)	Boom Angle	Rating (Pounds)
	44	80.8	31,790*	-	-	-	-
	50	79.3	31,190*	-	-	-	-
	60	76.6	30,230*	78.8	27,630*	80.8	25,710*
	70	73.9	29,400*	76.1	27,080*	78.1	25,240*
	80	71.2	28,560*	73.3	26,430*	75.3	23,620*
	90	68.4	27,740*	70.5	25,900*	72.5	22,120*
<b>170' (51.8 m)</b>	100	65.6	26,960	67.7	25,390*	69.6	20,860*
	110	62.7	23,430	64.7	23,430	66.6	19,740*
	120	59.7	20,530	61.7	20,540	63.6	18,750*
	130	56.6	18,120	58.6	18,130	60.4	17,850*
	140	53.4	16,090	55.4	16,100	57.1	16,110
	150	50.1	14,350	52.0	14,350	53.7	14,370
	160	46.5	12,850	48.5	12,860	50.0	12,870
	170	42.8	11,540	44.7	11,550	46.2	11,560

	45	81.0	31,770*	-	-	-	-
	50	79.7	31,230*	-	-	-	-
	60	77.2	30,360*	79.3	27,700*	-	-
	70	74.6	29,520*	76.7	27,140*	78.6	25,220*
	80	72.0	28,650*	74.1	26,540*	76.0	23,960*
	90	69.4	27,990*	71.4	25,950*	73.3	22,470*
<b>180' (54.9 m)</b>	100	66.7	26,590	68.7	25,480*	70.5	21,210*
	110	64.0	23,050	65.9	23,060	67.7	20,100*
	120	61.1	20,160	63.1	20,170	64.9	19,070*
	130	58.2	17,750	60.2	17,750	61.9	17,770
	140	55.2	15,710	57.2	15,720	58.8	15,730
	150	52.1	13,970	54.0	13,970	55.6	13,990
	160	48.9	12,470	50.7	12,470	52.3	12,490
	170	45.4	11,150	47.3	11,160	48.8	11,170
	180	41.8	10,000	43.6	10,010	45.0	10,030

	47	80.9	31,550*	-	-	-	-
	50	80.2	31,380*	-	-	-	-
	60	77.7	30,470*	79.7	27,760*	-	-
	70	75.3	29,610*	77.3	27,170*	79.1	25,220*
	80	72.8	28,830*	74.8	26,540*	76.6	24,260*
	90	70.3	28,090*	72.2	26,080*	74.0	22,820*
<b>190' (57.9 m)</b>	100	67.7	26,170	69.7	25,530*	71.4	21,520*
	110	65.1	22,630	67.0	22,640	68.8	20,420*
	120	62.5	19,740	64.3	19,740	66.0	19,400*
	130	59.7	17,320	61.6	17,330	63.2	17,340
	140	56.9	15,280	58.8	15,290	60.4	15,300
	150	54.0	13,540	55.8	13,540	57.4	13,560
	160	50.9	12,030	52.8	12,040	54.3	12,060
	170	47.8	10,720	49.5	10,720	51.0	10,740
	180	44.4	9,560	46.2	9,570	47.6	9,590
	190	40.8	8,540	42.5	8,550	43.9	8,570

Boom length	Jib Radius (Feet)	5.0 Deg offset		15.0 Deg offset		25.0 Deg offset	
		Boom Angle	Rating (Pounds)	Boom Angle	Rating (Pounds)	Boom Angle	Rating (Pounds)
	49	80.8	31,430*	-	-	-	-
	50	80.6	31,320*	-	-	-	-
	60	78.2	30,580*	80.1	27,800*	-	-
	70	75.9	29,760*	77.8	27,210*	79.6	25,200*
	80	73.5	29,010*	75.4	26,650*	77.1	24,550*
	90	71.1	28,290*	73.0	26,090*	74.7	23,100*
	100	68.7	25,760	70.5	25,700*	72.2	21,810*
	110	66.2	22,220	68.0	22,230	69.7	20,740*
<b>200' (61.0 m)</b>	120	63.6	19,320	65.5	19,330	67.1	19,340
	130	61.0	16,910	62.9	16,910	64.5	16,930
	140	58.4	14,870	60.2	14,870	61.7	14,890
	150	55.6	13,120	57.4	13,130	58.9	13,140
	160	52.8	11,600	54.5	11,610	56.0	11,630
	170	49.8	10,290	51.6	10,300	53.0	10,310
	180	46.7	9,140	48.4	9,140	49.8	9,160
	190	43.5	8,110	45.1	8,120	46.4	8,140
	200	40.0	7,210	41.6	7,220	42.8	7,240

	50	80.9	31,350*	-	-	-	-
	60	78.7	30,550*	80.5	27,740*	-	-
	70	76.4	29,800*	78.3	27,230*	80.0	25,170*
	80	74.2	29,040*	76.0	26,620*	77.7	24,770*
	90	71.9	28,360*	73.7	26,200*	75.3	23,470*
	100	69.5	25,340	71.3	25,350	72.9	22,180*
	110	67.1	21,800	68.9	21,800	70.5	21,080*
	120	64.7	18,890	66.5	18,900	68.1	18,910
<b>210' (64.0 m)</b>	130	62.3	16,470	64.0	16,480	65.6	16,490
	140	59.7	14,430	61.5	14,440	63.0	14,450
	150	57.1	12,680	58.9	12,690	60.3	12,700
	160	54.5	11,160	56.2	11,170	57.6	11,190
	170	51.7	9,850	53.4	9,860	54.8	9,870
	180	48.8	8,690	50.4	8,700	51.8	8,710
	190	45.8	7,670	47.4	7,670	48.7	7,690
	200	42.6	6,760	44.2	6,760	45.4	6,780
	210	39.1	5,950	40.7	5,960	41.8	5,980

	52	80.8	31,140*	-	-	-	-
	60	79.1	30,600*	80.9	27,680*	-	-
	70	76.9	29,800*	78.7	27,140*	80.4	25,100*
	80	74.8	29,070*	76.5	26,710*	78.1	24,800*
	90	72.6	28,420*	74.3	26,190*	75.9	23,730*
	100	70.3	24,920	72.0	24,930	73.6	22,420*
	110	68.0	21,380	69.8	21,380	71.3	21,380*
	120	65.7	18,470	67.4	18,470	69.0	18,490
<b>220' (67.1 m)</b>	130	63.4	16,050	65.1	16,060	66.6	16,070
	140	61.0	14,010	62.6	14,010	64.1	14,030
	150	58.5	12,260	60.2	12,260	61.6	12,280
	160	56.0	10,740	57.6	10,740	59.0	10,760
	170	53.4	9,420	55.0	9,430	56.3	9,440
	180	50.6	8,260	52.2	8,270	53.6	8,280
	190	47.8	7,230	49.4	7,240	50.7	7,250
	200	44.8	6,320	46.4	6,330	47.6	6,340
	210	41.7	5,510	43.2	5,520	44.4	5,530
	220	38.4	4,780	39.9	4,790	40.9	4,800



**WITH 77SI OFFSET TIP BOOM AND 116,400 POUND COUNTERWEIGHT  
#16HL JIB**

108,400 lb + 8,000 lb carbody counterweight

360°

ANSI B 30.5

**50' (15.2 m) Jib length**

Boom length	Jib Radius (Feet)	5.0 Deg offset		15.0 Deg offset		25.0 Deg offset	
		Boom Angle	Rating (Pounds)	Boom Angle	Rating (Pounds)	Boom Angle	Rating (Pounds)
	53	81.0	31,080*	-	-	-	-
	60	79.5	30,600*	-	-	-	-
	70	77.4	29,850*	79.1	27,190*	80.7	24,980*
	80	75.3	29,110*	77.0	26,710*	78.6	24,700*
	90	73.2	28,480*	74.9	26,190*	76.4	23,990*
	100	71.0	24,530	72.7	24,540	74.2	22,790*
	110	68.9	20,990	70.5	20,990	72.0	21,010
	120	66.7	18,080	68.3	18,080	69.8	18,100
<b>230' (70.1 m)</b>	130	64.4	15,660	66.0	15,670	67.5	15,680
	140	62.1	13,610	63.7	13,620	65.2	13,630
	150	59.8	11,860	61.4	11,870	62.8	11,880
	160	57.3	10,340	58.9	10,350	60.3	10,360
	170	54.9	9,010	56.4	9,020	57.8	9,030
	180	52.3	7,860	53.9	7,870	55.2	7,880
	190	49.7	6,830	51.2	6,840	52.5	6,850
	200	46.9	5,910	48.4	5,920	49.6	5,940
	210	44.0	5,100	45.5	5,110	46.6	5,120
	220	40.9	4,360	42.4	4,370	43.5	4,390
	230	37.6	3,710	39.1	3,720	40.1	3,740

Boom length	Jib Radius (Feet)	5.0 Deg offset		15.0 Deg offset		25.0 Deg offset	
		Boom Angle	Rating (Pounds)	Boom Angle	Rating (Pounds)	Boom Angle	Rating (Pounds)
	56	81.0	30,720*	-	-	-	-
	60	80.2	30,390*	-	-	-	-
	70	78.3	29,780*	79.9	27,030*	-	-
	80	76.3	29,170*	77.9	26,550*	79.4	24,540*
	90	74.3	28,130	75.9	26,120*	77.4	24,260*
	100	72.4	23,700	73.9	23,710	75.3	23,310*
	110	70.3	20,150	71.9	20,150	73.3	20,170
	120	68.3	17,240	69.8	17,240	71.2	17,250
<b>250' (76.2 m)</b>	130	66.2	14,810	67.8	14,810	69.1	14,820
	140	64.1	12,760	65.6	12,760	67.0	12,780
	150	62.0	11,000	63.5	11,010	64.8	11,020
	160	59.8	9,480	61.3	9,490	62.6	9,500
	170	57.5	8,150	59.0	8,160	60.3	8,170
	180	55.2	6,980	56.7	6,990	57.9	7,000
	190	52.8	5,960	54.3	5,960	55.5	5,980
	200	50.4	5,030	51.8	5,040	53.0	5,060
	210	47.9	4,210	49.3	4,210	50.4	4,230
	220	45.2	3,470	46.6	3,480	47.7	3,500
	230	42.4	2,810	43.8	2,820	44.8	2,840
	240	39.5	2,210	40.8	2,220	41.8	2,240

	55	80.9	30,840*	-	-	-	-
	60	79.9	30,530*	-	-	-	-
	70	77.9	29,880*	79.5	27,100*	-	-
	80	75.8	29,190*	77.5	26,690*	79.0	24,610*
	90	73.8	28,540	75.4	26,250*	76.9	24,230*
	100	71.7	24,110	73.3	24,120	74.8	23,040*
	110	69.6	20,570	71.2	20,570	72.7	20,590
	120	67.5	17,660	69.1	17,660	70.5	17,670
<b>240' (73.2 m)</b>	130	65.3	15,230	66.9	15,230	68.3	15,250
	140	63.1	13,180	64.7	13,190	66.1	13,200
	150	60.9	11,430	62.5	11,430	63.8	11,450
	160	58.6	9,900	60.1	9,910	61.5	9,930
	170	56.3	8,590	57.8	8,590	59.1	8,610
	180	53.8	7,420	55.3	7,430	56.6	7,440
	190	51.3	6,390	52.8	6,390	54.1	6,410
	200	48.7	5,470	50.2	5,470	51.4	5,490
	210	46.0	4,650	47.5	4,660	48.6	4,680
	220	43.2	3,910	44.6	3,920	45.7	3,940
	230	40.2	3,250	41.6	3,260	42.6	3,280
	240	37.0	2,660	38.3	2,670	39.3	2,690

**60' (18.3 m) Jib length**

Boom length	Jib Radius (Feet)	5.0 Deg offset		15.0 Deg offset		25.0 Deg offset	
		Boom Angle	Rating (Pounds)	Boom Angle	Rating (Pounds)	Boom Angle	Rating (Pounds)
	43	80.9	28,920*	-	-	-	-
	50	79.0	28,190*	-	-	-	-
	60	76.2	27,190*	78.9	24,740*	-	-
	70	73.4	26,160*	76.1	24,040*	78.6	21,560*
	80	70.5	25,280*	73.2	23,380*	75.7	20,000*
	90	67.6	24,480*	70.2	22,750*	72.7	18,670*
<b>150' (45.7 m)</b>	100	64.6	23,780*	67.2	21,830*	69.6	17,500*
	110	61.5	23,100*	64.1	20,370*	66.5	16,520*
	120	58.3	21,540	60.9	19,080*	63.2	15,660*
	130	55.0	19,130	57.6	18,020*	59.8	14,880*
	140	51.6	17,100	54.1	17,060*	56.3	14,230*
	150	47.9	15,360	50.4	15,370	52.5	13,700*

Boom length	Jib Radius (Feet)	5.0 Deg offset		15.0 Deg offset		25.0 Deg offset	
		Boom Angle	Rating (Pounds)	Boom Angle	Rating (Pounds)	Boom Angle	Rating (Pounds)
	45	80.8	28,710*	-	-	-	-
	50	79.5	28,220*	-	-	-	-
	60	76.8	27,220*	79.4	24,690*	-	-
	70	74.1	26,330*	76.7	24,110*	79.2	21,790*
	80	71.4	25,470*	74.0	23,480*	76.4	20,320*
	90	68.6	24,710*	71.2	22,890*	73.5	18,950*
<b>160' (48.8 m)</b>	100	65.8	24,020*	68.3	22,290*	70.6	17,790*
	110	62.9	23,300*	65.4	20,920*	67.7	16,820*
	120	59.9	21,120	62.4	19,670*	64.6	15,980*
	130	56.8	18,710	59.3	18,550*	61.4	15,170*
	140	53.6	16,680	56.0	16,690	58.1	14,540*
	150	50.3	14,940	52.7	14,950	54.7	13,950*
	160	46.7	13,430	49.1	13,440	51.0	13,460

**WITH 77SI OFFSET TIP BOOM AND 116,400 POUND COUNTERWEIGHT**  
**#16HL JIB**

108,400 lb + 8,000 lb carbody counterweight

360°

ANSI B 30.5

**60' (18.3 m) Jib length**

Boom length	Jib Radius (Feet)	5.0 Deg offset		15.0 Deg offset		25.0 Deg offset	
		Boom Angle	Rating (Pounds)	Boom Angle	Rating (Pounds)	Boom Angle	Rating (Pounds)
	46	81.0	28,710*	-	-	-	-
	50	79.9	28,370*	-	-	-	-
	60	77.4	27,410*	79.9	24,820*	-	-
	70	74.8	26,500*	77.3	24,100*	79.6	22,130*
	80	72.2	25,670*	74.7	23,590*	77.0	20,560*
	90	69.6	24,880*	72.0	22,940*	74.3	19,210*
<b>170'</b> <b>(51.8 m)</b>	100	66.9	24,210*	69.3	22,410*	71.6	18,150*
	110	64.2	23,560*	66.6	21,450*	68.8	17,160*
	120	61.4	20,710	63.7	20,120*	65.9	16,270*
	130	58.5	18,300	60.8	18,310	62.9	15,510*
	140	55.5	16,260	57.8	16,270	59.8	14,810*
	150	52.3	14,520	54.6	14,520	56.6	14,210*
	160	49.1	13,010	51.3	13,010	53.3	13,030
	170	45.6	11,700	47.9	11,710	49.7	11,730

	48	80.8	28,530*	-	-	-	-
	50	80.4	28,420*	-	-	-	-
	60	77.9	27,470*	80.3	24,840*	-	-
	70	75.5	26,670*	77.9	24,210*	80.1	22,280*
	80	73.0	25,850*	75.4	23,600*	77.6	20,810*
	90	70.5	25,060*	72.8	23,080*	75.0	19,570*
<b>180'</b> <b>(54.9 m)</b>	100	67.9	24,410*	70.3	22,540*	72.4	18,400*
	110	65.3	23,220	67.6	21,960*	69.7	17,400*
	120	62.7	20,330	64.9	20,330	67.0	16,570*
	130	59.9	17,910	62.2	17,920	64.2	15,750*
	140	57.1	15,870	59.3	15,880	61.3	15,070*
	150	54.2	14,130	56.4	14,130	58.3	14,150
	160	51.1	12,620	53.3	12,630	55.2	12,650
	170	48.0	11,310	50.1	11,310	51.9	11,330
	180	44.6	10,160	46.7	10,170	48.4	10,190

	49	81.0	28,420*	-	-	-	-
	50	80.8	28,350*	-	-	-	-
	60	78.4	27,480*	80.7	24,760*	-	-
	70	76.1	26,720*	78.4	24,200*	80.5	22,240*
	80	73.7	25,940*	76.0	23,700*	78.1	21,050*
	90	71.3	25,200*	73.6	23,090*	75.6	19,790*
<b>190'</b> <b>(57.9 m)</b>	100	68.9	24,580*	71.1	22,630*	73.2	18,670*
	110	66.4	22,800	68.6	22,190*	70.6	17,700*
	120	63.8	19,900	66.0	19,910	68.0	16,790*
	130	61.2	17,490	63.4	17,500	65.4	16,000*
	140	58.6	15,450	60.7	15,450	62.7	15,360*
	150	55.8	13,700	58.0	13,710	59.8	13,720
	160	53.0	12,190	55.1	12,200	56.9	12,220
	170	50.0	10,870	52.1	10,880	53.9	10,900
	180	46.9	9,730	49.0	9,730	50.7	9,750
	190	43.7	8,700	45.7	8,710	47.3	8,730

Boom length	Jib Radius (Feet)	5.0 Deg offset		15.0 Deg offset		25.0 Deg offset	
		Boom Angle	Rating (Pounds)	Boom Angle	Rating (Pounds)	Boom Angle	Rating (Pounds)
	51	80.9	28,250*	-	-	-	-
	60	78.9	27,540*	-	-	-	-
	70	76.6	26,750*	78.8	24,200*	80.9	22,160*
	80	74.4	26,060*	76.5	23,690*	78.6	21,350*
	90	72.0	25,320*	74.2	23,160*	76.2	20,030*
	100	69.7	24,740*	71.9	22,720*	73.9	18,950*
<b>200'</b> <b>(61.0 m)</b>	110	67.3	22,390	69.5	22,220*	71.4	17,890*
	120	64.9	19,490	67.0	19,500	69.0	17,080*
	130	62.5	17,070	64.6	17,080	66.4	16,300*
	140	59.9	15,030	62.0	15,040	63.9	15,050
	150	57.3	13,280	59.4	13,290	61.2	13,310
	160	54.6	11,760	56.7	11,770	58.5	11,790
	170	51.9	10,450	53.9	10,460	55.6	10,480
	180	49.0	9,290	51.0	9,300	52.6	9,320
	190	45.9	8,270	47.9	8,280	49.5	8,290
	200	42.7	7,370	44.7	7,380	46.2	7,400

	53	80.8	28,110*	-	-	-	-
	60	79.3	27,580*	-	-	-	-
	70	77.1	26,900*	79.2	24,200*	-	-
	80	74.9	26,160*	77.0	23,670*	79.0	21,580*
	90	72.7	25,440*	74.8	23,200*	76.8	20,280*
	100	70.5	24,770*	72.6	22,740*	74.5	19,130*
	110	68.2	21,970	70.3	21,970	72.2	18,220*
	120	65.9	19,070	68.0	19,080	69.8	17,270*
<b>210'</b> <b>(64.0 m)</b>	130	63.6	16,640	65.6	16,650	67.4	16,520*
	140	61.2	14,600	63.2	14,610	65.0	14,620
	150	58.7	12,850	60.7	12,850	62.4	12,870
	160	56.1	11,340	58.1	11,350	59.9	11,360
	170	53.5	10,010	55.5	10,020	57.2	10,040
	180	50.8	8,850	52.8	8,860	54.4	8,880
	190	48.0	7,830	49.9	7,840	51.5	7,860
	200	45.0	6,920	46.9	6,930	48.4	6,950
	210	41.9	6,110	43.7	6,120	45.2	6,140

	54	80.9	27,970*	-	-	-	-
	60	79.7	27,630*	-	-	-	-
	70	77.6	26,930*	79.6	24,190*	-	-
	80	75.5	26,250*	77.5	23,760*	79.4	21,710*
	90	73.4	25,540*	75.4	23,270*	77.3	20,450*
	100	71.2	24,900*	73.2	22,810*	75.1	19,380*
	110	69.0	21,550	71.0	21,550	72.9	18,380*
	120	66.8	18,650	68.8	18,650	70.6	17,510*
<b>220'</b> <b>(67.1 m)</b>	130	64.6	16,220	66.5	16,230	68.3	16,240
	140	62.3	14,170	64.2	14,180	66.0	14,200
	150	59.9	12,420	61.9	12,430	63.6	12,440
	160	57.5	10,910	59.4	10,920	61.1	10,930
	170	55.0	9,580	56.9	9,590	58.6	9,610
	180	52.5	8,420	54.4	8,430	56.0	8,440
	190	49.8	7,400	51.7	7,410	53.2	7,420
	200	47.1	6,480	48.9	6,490	50.4	6,510
	210	44.2	5,670	46.0	5,680	47.4	5,700
	220	41.1	4,930	42.9	4,940	44.2	4,960



**WITH 77SI OFFSET TIP BOOM AND 116,400 POUND COUNTERWEIGHT  
#16HL JIB**

108,400 lb + 8,000 lb carbody counterweight

360°

ANSI B 30.5

**60' (18.3 m) Jib length**

Boom length	Jib Radius (Feet)	5.0 Deg offset		15.0 Deg offset		25.0 Deg offset	
		Boom Angle	Rating (Pounds)	Boom Angle	Rating (Pounds)	Boom Angle	Rating (Pounds)
	56	80.8	27,840*	-	-	-	-
	60	80.0	27,570*	-	-	-	-
	70	78.0	26,840*	80.0	24,130*	-	-
	80	76.0	26,230*	78.0	23,660*	79.8	21,720*
	90	74.0	25,540*	75.9	23,230*	77.7	20,700*
	100	71.9	24,710	73.8	22,800*	75.6	19,610*
	110	69.8	21,160	71.7	21,160	73.5	18,610*
	120	67.7	18,250	69.6	18,250	71.3	17,760*
<b>230' (70.1 m)</b>	130	65.5	15,830	67.4	15,830	69.1	15,850
	140	63.3	13,780	65.2	13,790	66.9	13,800
	150	61.1	12,030	62.9	12,030	64.6	12,050
	160	58.8	10,500	60.6	10,510	62.3	10,530
	170	56.4	9,190	58.3	9,190	59.9	9,210
	180	54.0	8,020	55.8	8,030	57.4	8,040
	190	51.5	6,990	53.3	7,000	54.8	7,010
	200	48.9	6,080	50.7	6,090	52.1	6,100
	210	46.2	5,250	47.9	5,260	49.4	5,280
	220	43.3	4,520	45.1	4,530	46.4	4,550
	230	40.3	3,860	42.0	3,870	43.3	3,900

Boom length	Jib Radius (Feet)	5.0 Deg offset		15.0 Deg offset		25.0 Deg offset	
		Boom Angle	Rating (Pounds)	Boom Angle	Rating (Pounds)	Boom Angle	Rating (Pounds)
	59	80.9	27,460*	-	-	-	-
	60	80.7	27,450*	-	-	-	-
	70	78.8	26,780*	80.7	23,960*	-	-
	80	76.9	26,180*	78.8	23,590*	80.5	21,510*
	90	75.0	25,570*	76.9	23,140*	78.6	21,100*
	100	73.1	23,870	74.9	22,800*	76.6	20,000*
	110	71.2	20,320	73.0	20,320	74.6	19,030*
	120	69.2	17,400	71.0	17,410	72.6	17,430
	130	67.2	14,970	69.0	14,980	70.6	15,000
	140	65.2	12,930	66.9	12,930	68.5	12,950
<b>250' (76.2 m)</b>	150	63.1	11,170	64.9	11,180	66.4	11,190
	160	61.0	9,650	62.8	9,650	64.3	9,670
	170	58.9	8,320	60.6	8,330	62.1	8,350
	180	56.7	7,150	58.4	7,160	59.9	7,180
	190	54.4	6,120	56.1	6,130	57.6	6,140
	200	52.1	5,190	53.8	5,200	55.2	5,220
	210	49.7	4,370	51.3	4,380	52.7	4,400
	220	47.2	3,640	48.8	3,650	50.2	3,660
	230	44.6	2,970	46.2	2,980	47.5	3,000
	240	41.8	2,360	43.4	2,380	44.7	2,400
	250	38.9	1,820	40.5	1,830	41.6	1,860

	57	81.0	27,710*	-	-	-	-
	60	80.4	27,520*	-	-	-	-
	70	78.4	26,860*	80.3	24,120*	-	-
	80	76.5	26,200*	78.4	23,660*	80.2	21,650*
	90	74.5	25,590*	76.4	23,190*	78.2	20,910*
	100	72.5	24,280	74.4	22,850*	76.1	19,810*
	110	70.5	20,740	72.4	20,740	74.1	18,820*
	120	68.5	17,830	70.3	17,830	72.0	17,850
<b>240' (73.2 m)</b>	130	66.4	15,400	68.2	15,400	69.9	15,420
	140	64.3	13,350	66.1	13,360	67.8	13,370
	150	62.1	11,590	63.9	11,600	65.6	11,620
	160	59.9	10,070	61.7	10,080	63.3	10,090
	170	57.7	8,750	59.5	8,760	61.0	8,770
	180	55.4	7,580	57.2	7,590	58.7	7,610
	190	53.0	6,550	54.8	6,550	56.3	6,570
	200	50.6	5,630	52.3	5,640	53.7	5,660
	210	48.0	4,810	49.7	4,820	51.1	4,830
	220	45.4	4,070	47.0	4,080	48.4	4,100
	230	42.6	3,410	44.2	3,420	45.5	3,440
	240	39.6	2,820	41.2	2,830	42.5	2,850

**70' (21.3 m) Jib length**

Boom length	Jib Radius (Feet)	5.0 Deg offset		15.0 Deg offset		25.0 Deg offset	
		Boom Angle	Rating (Pounds)	Boom Angle	Rating (Pounds)	Boom Angle	Rating (Pounds)
	50	81.0	21,370*	-	-	-	-
	60	78.6	20,590*	-	-	-	-
	70	76.3	19,880*	78.9	17,820*	-	-
	80	73.9	19,250*	76.6	17,310*	79.1	15,880*
	90	71.5	18,560*	74.1	16,840*	76.6	15,420*
	100	69.1	18,010*	71.7	16,440*	74.1	14,990*
<b>180' (54.9 m)</b>	110	66.6	17,440*	69.2	15,960*	71.6	14,640*
	120	64.0	16,930*	66.6	15,480*	69.0	14,260*
	130	61.4	16,440*	64.0	15,000*	66.3	13,730*
	140	58.8	15,920*	61.3	14,640*	63.6	13,120*
	150	56.0	14,260	58.5	14,270	60.8	12,580*
	160	53.2	12,750	55.7	12,760	57.8	12,070*
	170	50.2	11,430	52.7	11,440	54.8	11,460
	180	47.1	10,290	49.5	10,300	51.6	10,320

**WITH 77SI OFFSET TIP BOOM AND 116,400 POUND COUNTERWEIGHT  
# 16HL JIB**

108,400 lb + 8,000 lb carbody counterweight

360°

ANSI B 30.5

**70' (21.3 m) Jib length**

Boom length	Jib Radius (Feet)	5.0 Deg offset Boom Angle	5.0 Deg offset Rating (Pounds)	15.0 Deg offset Boom Angle	15.0 Deg offset Rating (Pounds)	25.0 Deg offset Boom Angle	25.0 Deg offset Rating (Pounds)
	52	80.9	21,300*	-	-	-	-
	60	79.1	20,740*	-	-	-	-
	70	76.8	19,950*	79.4	17,910*	-	-
	80	74.5	19,320*	77.1	17,350*	79.5	15,870*
	90	72.2	18,740*	74.8	16,890*	77.2	15,440*
	100	69.9	18,130*	72.4	16,510*	74.8	15,020*
<b>190' (57.9 m)</b>	110	67.5	17,580*	70.0	16,110*	72.3	14,680*
	120	65.1	17,080*	67.6	15,600*	69.9	14,360*
	130	62.6	16,620*	65.1	15,130*	67.3	13,960*
	140	60.1	15,580	62.6	14,730*	64.8	13,320*
	150	57.5	13,830	59.9	13,840	62.1	12,790*
	160	54.8	12,320	57.2	12,330	59.3	12,310*
	170	52.1	11,000	54.4	11,010	56.5	11,030
	180	49.2	9,850	51.5	9,860	53.5	9,880
	190	46.1	8,830	48.4	8,840	50.4	8,860

	53	81.0	21,240*	-	-	-	-
	60	79.5	20,790*	-	-	-	-
	70	77.3	20,110*	79.8	17,920*	-	-
	80	75.1	19,390*	77.6	17,400*	79.9	15,860*
	90	72.9	18,830*	75.4	16,940*	77.7	15,520*
	100	70.7	18,230*	73.1	16,580*	75.4	15,120*
<b>200' (61.0 m)</b>	110	68.4	17,700*	70.8	16,130*	73.1	14,730*
	120	66.1	17,210*	68.5	15,720*	70.7	14,420*
	130	63.7	16,780*	66.1	15,320*	68.3	14,100*
	140	61.3	15,170	63.7	14,870*	65.8	13,550*
	150	58.9	13,420	61.2	13,420	63.3	12,970*
	160	56.3	11,900	58.7	11,910	60.7	11,920
	170	53.7	10,580	56.0	10,590	58.0	10,610
	180	51.0	9,420	53.3	9,430	55.2	9,450
	190	48.2	8,400	50.4	8,410	52.3	8,430
	200	45.2	7,490	47.4	7,500	49.2	7,520

	55	80.9	21,110*	-	-	-	-
	60	79.9	20,840*	-	-	-	-
	70	77.8	20,100*	80.2	17,940*	-	-
	80	75.7	19,530*	78.0	17,440*	80.3	15,840*
	90	73.5	18,900*	75.9	17,040*	78.1	15,490*
	100	71.4	18,420*	73.7	16,630*	75.9	15,130*
	110	69.2	17,850*	71.6	16,200*	73.7	14,760*
	120	67.0	17,380*	69.3	15,860*	71.5	14,470*
<b>210' (64.0 m)</b>	130	64.8	16,780	67.1	15,400*	69.2	14,160*
	140	62.5	14,730	64.7	14,740	66.8	13,740*
	150	60.1	12,980	62.4	12,990	64.4	13,010
	160	57.7	11,470	59.9	11,480	61.9	11,500
	170	55.2	10,140	57.4	10,150	59.4	10,170
	180	52.7	8,990	54.9	9,000	56.8	9,020
	190	50.0	7,960	52.2	7,970	54.0	7,990
	200	47.2	7,040	49.4	7,050	51.2	7,070
	210	44.3	6,230	46.5	6,240	48.2	6,260

Boom length	Jib Radius (Feet)	5.0 Deg offset Boom Angle	5.0 Deg offset Rating (Pounds)	15.0 Deg offset Boom Angle	15.0 Deg offset Rating (Pounds)	25.0 Deg offset Boom Angle	25.0 Deg offset Rating (Pounds)
	57	80.8	21,020*	-	-	-	-
	60	80.2	20,800*	-	-	-	-
	70	78.2	20,170*	80.5	17,880*	-	-
	80	76.2	19,590*	78.5	17,420*	80.6	15,770*
	90	74.1	18,980*	76.4	17,010*	78.6	15,500*
	100	72.1	18,500*	74.3	16,610*	76.4	15,210*
	110	70.0	17,920*	72.2	16,260*	74.3	14,820*
	120	67.8	17,470*	70.1	15,920*	72.1	14,510*
<b>220' (67.1 m)</b>	130	65.7	16,360	67.9	15,550*	69.9	14,200*
	140	63.5	14,310	65.7	14,320	67.7	13,910*
	150	61.2	12,560	63.4	12,570	65.4	12,580
	160	58.9	11,040	61.1	11,050	63.1	11,070
	170	56.6	9,720	58.8	9,720	60.6	9,740
	180	54.2	8,550	56.3	8,560	58.2	8,580
	190	51.7	7,530	53.8	7,540	55.6	7,560
	200	49.1	6,610	51.2	6,620	52.9	6,640
	210	46.4	5,790	48.4	5,800	50.1	5,820
	220	43.5	5,060	45.5	5,070	47.2	5,090

	58	80.9	20,970*	-	-	-	-
	60	80.5	20,850*	-	-	-	-
	70	78.6	20,270*	80.8	17,900*	-	-
	80	76.6	19,650*	78.9	17,460*	81.0	15,780*
	90	74.7	19,050*	76.9	17,050*	79.0	15,520*
	100	72.7	18,540*	74.9	16,660*	76.9	15,230*
	110	70.7	18,070*	72.9	16,280*	74.9	14,910*
	120	68.6	17,570*	70.8	15,970*	72.8	14,560*
<b>230' (70.1 m)</b>	130	66.5	15,970	68.7	15,620*	70.7	14,240*
	140	64.4	13,920	66.6	13,930	68.5	13,940
	150	62.3	12,160	64.4	12,170	66.3	12,190
	160	60.1	10,640	62.2	10,650	64.1	10,670
	170	57.9	9,320	59.9	9,330	61.8	9,350
	180	55.5	8,150	57.6	8,160	59.4	8,180
	190	53.2	7,120	55.2	7,130	57.0	7,150
	200	50.7	6,200	52.8	6,210	54.5	6,230
	210	48.2	5,390	50.2	5,400	51.9	5,420
	220	45.5	4,640	47.5	4,650	49.1	4,670
	230	42.7	3,980	44.7	3,990	46.2	4,020

	60	80.8	20,810*	-	-	-	-
	70	79.0	20,240*	-	-	-	-
	80	77.1	19,710*	79.2	17,460*	-	-
	90	75.2	19,110*	77.3	17,080*	79.3	15,430*
	100	73.3	18,650*	75.4	16,700*	77.4	15,190*
	110	71.3	18,110*	73.4	16,300*	75.4	14,920*
	120	69.3	17,630*	71.5	16,000*	73.4	14,580*
	130	67.3	15,530	69.4	15,540	71.4	14,310*
<b>240' (73.2 m)</b>	140	65.3	13,490	67.4	13,490	69.3	13,510
	150	63.3	11,730	65.3	11,740	67.2	11,760
	160	61.2	10,220	63.2	10,220	65.0	10,240
	170	59.0	8,880	61.1	8,890	62.9	8,910
	180	56.8	7,710	58.8	7,720	60.6	7,740
	190	54.6	6,690	56.6	6,700	58.3	6,720
	200	52.2	5,760	54.2	5,770	55.9	5,790
	210	49.8	4,940	51.8	4,950	53.4	4,970
	220	47.3	4,210	49.3	4,220	50.9	4,240
	230	44.7	3,530	46.6	3,540	48.2	3,570
	240	42.0	2,930	43.9	2,950	45.3	2,970



**WITH 77SI OFFSET TIP BOOM AND 116,400 POUND COUNTERWEIGHT  
#16HL JIB**

108,400 lb + 8,000 lb carbody counterweight

360°

ANSI B 30.5

**80' (24.4 m) Jib length**

Boom length	Jib Radius (Feet)	5.0 Deg offset		15.0 Deg offset		25.0 Deg offset	
		Boom Angle	Rating (Pounds)	Boom Angle	Rating (Pounds)	Boom Angle	Rating (Pounds)
	56	80.9	16,550*	-	-	-	-
	60	80.0	16,300*	-	-	-	-
	70	77.9	15,600*	80.7	13,680*	-	-
	80	75.8	15,020*	78.6	13,260*	-	-
	90	73.7	14,470*	76.4	12,760*	79.0	11,270*
	100	71.6	14,000*	74.3	12,310*	76.8	10,920*
<b>200' (61.0 m)</b>	110	69.4	13,490*	72.1	11,870*	74.6	10,600*
	120	67.2	12,980*	69.8	11,470*	72.3	10,340*
	130	64.9	12,480*	67.6	11,080*	70.0	10,060*
	140	62.6	12,000*	65.3	10,760*	67.6	9,860*
	150	60.3	11,600*	62.9	10,450*	65.2	9,660*
	160	57.9	11,200*	60.5	10,190*	62.8	9,450*
	170	55.4	10,700	58.0	9,970*	60.2	9,290*
	180	52.8	9,550	55.4	9,560	57.6	9,150*
	190	50.2	8,520	52.7	8,530	54.8	8,550
	200	47.4	7,600	49.9	7,610	52.0	7,640

	57	81.0	16,490*	-	-	-	-
	60	80.4	16,280*	-	-	-	-
	70	78.4	15,710*	-	-	-	-
	80	76.3	15,130*	79.0	13,280*	-	-
	90	74.3	14,550*	76.9	12,850*	79.4	11,290*
	100	72.2	14,090*	74.8	12,350*	77.3	10,940*
	110	70.1	13,600*	72.7	11,950*	75.1	10,640*
	120	68.0	13,150*	70.6	11,560*	73.0	10,360*
<b>210' (64.0 m)</b>	130	65.9	12,640*	68.4	11,180*	70.8	10,130*
	140	63.7	12,160*	66.2	10,840*	68.5	9,900*
	150	61.4	11,750*	63.9	10,540*	66.2	9,670*
	160	59.1	11,350*	61.6	10,280*	63.9	9,490*
	170	56.8	10,280	59.2	10,020*	61.4	9,320*
	180	54.3	9,110	56.8	9,120	58.9	9,140
	190	51.8	8,090	54.3	8,100	56.4	8,120
	200	49.2	7,170	51.6	7,180	53.7	7,200
	210	46.5	6,350	48.9	6,360	50.9	6,390

	59	80.9	16,420*	-	-	-	-
	60	80.7	16,300*	-	-	-	-
	70	78.8	15,750*	-	-	-	-
	80	76.8	15,170*	79.4	13,260*	-	-
	90	74.8	14,630*	77.4	12,880*	79.8	11,310*
	100	72.8	14,180*	75.4	12,420*	77.7	10,970*
	110	70.8	13,690*	73.3	12,010*	75.7	10,670*
	120	68.8	13,290*	71.3	11,590*	73.6	10,420*
<b>220' (67.1 m)</b>	130	66.7	12,830*	69.2	11,280*	71.5	10,160*
	140	64.6	12,350*	67.1	10,920*	69.3	9,930*
	150	62.5	11,930*	64.9	10,620*	67.1	9,730*
	160	60.3	11,170	62.7	10,340*	64.9	9,520*
	170	58.0	9,850	60.4	9,860	62.6	9,380*
	180	55.7	8,680	58.1	8,690	60.2	8,710
	190	53.3	7,660	55.7	7,670	57.8	7,690
	200	50.9	6,730	53.2	6,750	55.2	6,770
	210	48.3	5,920	50.7	5,930	52.6	5,950
	220	45.7	5,180	48.0	5,190	49.8	5,220

Boom length	Jib Radius (Feet)	5.0 Deg offset		15.0 Deg offset		25.0 Deg offset	
		Boom Angle	Rating (Pounds)	Boom Angle	Rating (Pounds)	Boom Angle	Rating (Pounds)
	61	80.8	16,310*	-	-	-	-
	70	79.1	15,790*	-	-	-	-
	80	77.2	15,220*	79.7	13,300*	-	-
	90	75.3	14,700*	77.8	12,920*	80.1	11,330*
	100	73.4	14,200*	75.9	12,480*	78.1	10,990*
	110	71.5	13,770*	73.9	12,080*	76.2	10,670*
	120	69.5	13,340*	71.9	11,670*	74.2	10,420*
	130	67.5	12,960*	69.9	11,320*	72.1	10,180*
<b>230' (70.1 m)</b>	140	65.5	12,480*	67.9	10,990*	70.1	9,970*
	150	63.4	12,030*	65.8	10,720*	67.9	9,740*
	160	61.3	10,780	63.7	10,440*	65.8	9,560*
	170	59.2	9,440	61.5	9,450	63.6	9,380*
	180	57.0	8,280	59.3	8,290	61.3	8,320
	190	54.7	7,250	57.0	7,260	59.0	7,280
	200	52.4	6,330	54.7	6,340	56.6	6,370
	210	50.0	5,510	52.2	5,520	54.2	5,550
	220	47.5	4,770	49.7	4,780	51.6	4,800
	230	44.9	4,100	47.1	4,120	48.9	4,140

	62	80.9	16,250*	-	-	-	-
	70	79.5	15,800*	-	-	-	-
	80	77.6	15,260*	80.0	13,270*	-	-
	90	75.8	14,760*	78.2	12,950*	80.4	11,340*
	100	73.9	14,270*	76.3	12,590*	78.5	11,010*
	110	72.1	13,840*	74.4	12,140*	76.6	10,710*
	120	70.2	13,430*	72.5	11,740*	74.7	10,470*
	130	68.3	13,050*	70.6	11,420*	72.7	10,190*
<b>240' (73.2 m)</b>	140	66.3	12,630*	68.6	11,080*	70.7	9,990*
	150	64.3	11,870	66.6	10,790*	68.7	9,780*
	160	62.3	10,340	64.6	10,350	66.7	9,570*
	170	60.2	9,020	62.5	9,030	64.5	9,050
	180	58.1	7,850	60.4	7,860	62.4	7,880
	190	56.0	6,810	58.2	6,820	60.2	6,840
	200	53.8	5,890	56.0	5,910	57.9	5,930
	210	51.5	5,070	53.7	5,080	55.6	5,110
	220	49.1	4,330	51.3	4,340	53.1	4,370
	230	46.7	3,670	48.8	3,680	50.6	3,700
	240	44.1	3,060	46.2	3,080	47.9	3,100

**NOTES TO LIFTING CAPACITY**

**⚠ Warning**

This rating chart is invalid if the crane has been modified or altered by use of other than GENUINE AMERICAN PARTS as such modifications or alterations may affect its capacity or safe operation. See American Crane Corporation Service Bulliten #259.

Ratings in this chart are in POUNDS and do not exceed the percentage of tipping specified for this crane by ANSI B30.5. All ratings require that the crane be standing level on a firm uniformly supporting surface.

Do not lift loads in excess of those shown on this chart. Lifting loads in excess of those shown or operation not in accordance with good operating practice, including limitations shown on page 3499 of Operator's Manual, can cause tipping, structural damage or catastrophic failure.

Asterisk (\*) areas on this chart indicate ratings which are limited by strength of material or factors other than stability (tipping).

„JIB RADIUS IN FEET“ is the horizontal distance at ground level from the crane centerline of rotation to a vertical line through the center of gravity of the suspended load.

When using the main boom fall with jib in place, the main fall ratings must be reduced by the jib effective weight shown on the jib rating chart plus twice the weight of all suspended blocks, slings, rope, etc., at the jib fall. See Appendix A.

When using the main boom fall with boom tip extension in place, the main fall ratings must be reduced by the weight of the boom tip extension plus twice the weight of all suspended blocks, slings, rope, etc., at the boom tip extension fall. See Appendix A.

Blocks, slings, buckets and other load carrying devices are considered part of the load. The weight of standard hoisting ropes for the rating at a given radius has been calculated as part of the boom point load and need not be considered in determining net allowable loads. See Appendix A.

Ratings shown on this chart make no allowance for such factors as out of plumb loads, wind, poor soil conditions, improper inflation of rubber tires and dynamic effects due to excessive operating speeds. The user (operator) must exercise judgement to make allowance for these conditions. See page 3499 of Operator's Manual for detailed information.

No account is taken of the wind force on the load. This effect, which can be substantial for loads with large surface areas, must be considered by the user. In any wind it is strongly recommended that taglines be used to control the load.

BOOM HOIST LINE is 14 parts of 7/8 inch diameter EIPS wire rope with a minimum breaking strength of 79,600 pound.

PENDANT SUSPENSION LINE is 4 parts of 1.375 inch diameter EEIPS wire rope with a minimum breaking strength of 211,000 pound.

JIB BACKSTAY LINE AND FRONTSTAY LINES are 2 parts of 0.875 inch diameter wire rope with a minimum breaking strength of 69,200 pound.

WHIP LINE – 1.125 inch diameter EIPS wire rope with a minimum breaking strength of 130,000 pound or

ALTERNATE WHIP LINE (ROTATION RESISTANT) – 1.125 inch diameter BRIDON ENDURANCE DYFORM 34LR Grade 2160 wire rope with a minimum breaking strength of 167,200 pound.

**ERECTION**

Erection „OVER THE END“ is with the boom over the idler end with idler tumblers blocked (See operator's manual for blocking instructions). Erection „OVER THE SIDE“ is with the boom 90° to the sideframes and with the side frames extended. Blocks, slings and other load carrying devices must be on the ground during erection.

LOAD HOISTING INFORMATION - 1.125 inch diameter EIPS wire rope			
MAXIMUM LIFTING CAPACITY - LBS.	MINIMUM PARTS OF LINE	MAXIMUM HOISTING DISTANCE - FT	
		MAIN (FRONT)	AUX. (REAR)
32,000	1	1,312	1,312

LOAD HOISTING INFORMATION (ROTATION RESISTANT LOAD LINE) 1.125 inch diameter BRIDON ENDURANCE DYFORM 34LR Grade 2160 wire rope			
MAXIMUM LIFTING CAPACITY - LBS.	MINIMUM PARTS OF LINE	MAXIMUM HOISTING DISTANCE - FEET	
		MAIN (FRONT)	AUX. (REAR)
32,000	1	1,312	1,312

77SI OFFSET TIP BOOM COMPOSITION CHART							
BOOM LENGTH (METERS)	BOOM LENGTH (FEET)	BOOM SECTIONS					
		9.1 M 30' 77SI INNER	3.0 M 10' 77S CENTER	6.1 M 20' 77S CENTER	15.2 M 50' 77S CENTER	5.9 M 19.5' 77HL OUTER	9.1 M 30' 77LA OFFSET TIP
24.4 M	80	1	0	0	0	1	1
27.4 M	90	1	1	0	0	1	1
30.5 M	100	1	0	1	0	1	1
33.5 M	110	1	1	1	0	1	1
36.5 M	120	1	0	2	0	1	1
39.5 M	130	1	0	0	1	1	1
42.7 M	140	1	1	0	1	1	1
45.7 M	150	1	0	1	1	1	1
48.8 M	160	1	1	1	1	1	1
51.8 M	170	1	0	2	1	1	1
54.9 M	180	1	0	0	2	1	1
57.9 M	190	1	1	0	2	1	1
61.0 M	200	1	0	1	2	1	1
64.0 M	210	1	1	1	2	1	1
67.1 M	220	1	0	2	2	1	1
70.1 M	230	1	0	0	3	1	1
73.2 M	240	1	1	0	3	1	1
76.2 M	250	1	0	1	3	1	1
79.2 M	260	1	1	1	3	1	1
82.3 M	270	1	0	2	3	1	1

77SI OFFSET TIP BOOM MAXIMUM BOOM & JIB SELF-ERECTION DATA				
	OVER THE END		OVER THE SIDE	
	BOOM LENGTH (FT)	JIB LENGTH (FT)	BOOM LENGTH (FT)	JIB LENGTH (FT)
#16HL JIB	270	0	240	0
	260	0	230	60
	250	60	220	80
	240	80		

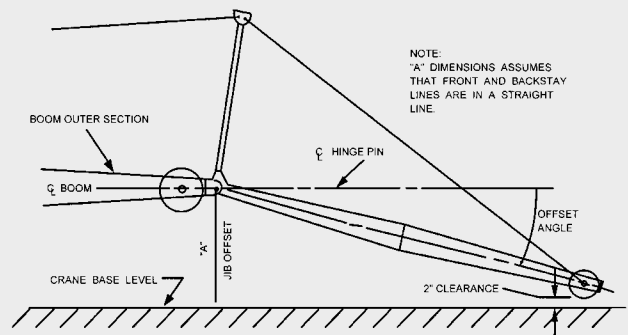

#16HL JIB COMPOSITION CHART								
JIB LENGTH (FEET)	20' INNER	10' CENTER	20' CENTER	20' OUTER	EFF. JIB WEIGHT (POUNDS)	JIB OFFSET \"A\" IN FEET		
						5'	15'	25'
40	1	0	0	1	1,500	4'-10"	10'- 2"	15'- 1"
50	1	1	0	1	2,050	5'- 8"	12'- 1"	18'- 3"
60	1	0	1	1	2,600	6'- 6"	13'-10"	21'- 2"
70	1	1	1	1	3,150	7'- 1"	15'-10"	24'- 4"
80	1	0	2	1	3,700	7'- 9"	17'- 8"	27'- 4"

## TECHNICAL DESCRIPTION

### HYDRAULIC CRAWLER CRANE

Maximum lifting capacity: 165 tons (149.6 tonnes).

#### Boom Systems:

77SI Tubular Boom w/ Offset Tip

- 270 ft (82.3 m) maximum boom length.
- 320 ft (240 ft + 80 ft) maximum boom and jib combination length.
- 77SI tubular chord boom, pin connected.
- 30 ft (19.8 m) inner, 19'5" outer base and 30 ft (19.8 m) outer and 10 / 20 / 50 ft (3 / 6 / 15 m) available inserts provide boom compositions in 10 ft (3 m) increments from 80 ft (24.4 m) to 270 ft (82.3 m).

77SI Tubular Boom w/ Hammerhead

- 240 ft (73.2 m) maximum boom length.
- 300 ft (220 ft + 80 ft) maximum boom and jib combination length.
- 77SI tubular chord boom, pin connected.
- 30 ft (19.8 m) inner, 19'5" outer base and hammerhead and 10 / 20 / 50 ft (3 / 6 / 15 m) available inserts provide boom compositions in 10 ft (3 m) increments from 50 ft (15.2 m) to 240 ft (73.2 m).

58ABSH Angle Boom

- Consult factory for details.

#### Robust engine

- Cummins Model QSC8.3 diesel engine supplies 325 HP (242 kW) @ 2000 rpm, 506 cu. in. (8.3 l) displacement, 112 gallons (425 l) fuel capacity.

#### Environmental operator's cab

- Designed to provide excellent viewing range and quiet, comfortable operation.
- 37 in. (0.91 m) wide cab has wide curved windows on both top and bottom.
- Easy-to-operate modular and ergonomically designed controls reduce operator fatigue and increase productivity.
- Load Moment Indicator with interactive screen features a shockless stop system. Operator can select from three display modes: loaded condition diagram, rated lifting curve, and rated lifting load table.
- Adjustable operator's seat, radio, air conditioner, overhead window, sun visor, fan, overhead and front wipers, and drum rotation indicators standard.

#### Heavy duty carbody and crawlers

- Fabricated steel carbody is deep box constructed with square axles for the crawler side frames. Precision machined top supports anti-friction swing circle and multiple pass hydraulic swivel joint.
- Crawlers have high alloy steel tumbler yokes and rigid fabricated structures with built-in sealed automatic lubrication system.
- 42" (1067 mm) crawler shoes.
- Travel mechanism is set within shoe width.
- Side frames extended or retracted by cylinders inside the carbody.
- Two travel speed settings – 0.55 / 0.37 mph (0.88 / 0.60 km/h).
- 30 % (17°) gradeability.

#### Powerful, high-speed hoist system

- Two identical independent main and auxiliary load hoisting drums provide ample lifting power. Drums are grooved for 1-1/8 in. (28 mm) diameter rope. Max. line speed is 540 fpm (165 m/min), max. single line pull is 54,060 lb (24 522 kg). Rated single line pull is 40,850 lb (18 530 kg). Freefall on main and auxiliary drums.
- Each drum, including optional third, has power up/down. Load hoists are further controllable in stepless mode.
- Ample work space in front of drums allows easy access for cable installation and maintenance.
- External contracting brake.
- Internal expanding band clutch.

#### Smooth swing

- Seperate swing circuit
- 2.0 rpm swing speed.

#### High capacity, dependable hydraulic system

- Open circuit system has 2 variable displacement piston pumps which supply power to the travel and hoisting functions, 3 gear pumps provide power for swing, hydraulic cylinders and pilot pressure.
- Hydraulic reservoir with 88.5 gallons (335 l) capacity and 10 micron filtration. System capacity is 132 gallons (500 l).
- Component working range is between -4 and 203° F (-20 and 95° C).

#### Seven piece removable counterweight

- 7 piece pin connected counterweight can be assembled or disassembled easily within minutes.
- Hydraulic counterweight removal system is standard and makes the HC165 one of the most transportable cranes in its class.
- Moves on 8 trucks with 240 ft (73.2 m) 77SI offset tip boom and 80 ft (24.4 m) of 16HL jib. At 11 ft 6-3/4 in. (3525 mm) wide and 11 ft 5-3/4 in. (3500 mm) high, the basic HC165 will transport on a standard lowboy trailer.

#### Options include:

- Third drum – machine mounted
- Third drum – boom inner mounted.
- Single sheave extension.
- 16HL tubular jib – 32,000 lb (14 515 kg) (77SI tubular boom only).
- #15 angle jib – 30,000 lb (13 600 kg) (58ABSH angle boom only).
- Optional 108,400 pound of upper and 8,000 pound of carbody counterweight.

**HOIST DRUM PERFORMANCE**

**MAIN AND AUXILIARY HOIST - 1 1/8" DIAMETER ROPE**

Rope Layer	High Range		Low Range		Total Rope Length
	Line Speed Feet Per Minute	Single Line Pull	Line Speed Feet Per Minute	Single Line Pull	
1st*	358	27.030	179	54.060	153
2nd*	389	24.910	194	49.850	313
3rd*	419	23.015	210	46.230	493
4th*	450	21.560	225	43.100	678
5th*	480	20.195	240	40.390	883
6th*	510	18.980	255	37.985	1.093
7th**	540	17.925	269	35.845	1.325
8th**	571	16.975	285	33.930	1.560
9th**	601	16.115	301	32.230	1.817

**3RD DRUM WITH FREE FALL**

**3RD DRUM WITHOUT FREE FALL**

Machine Mounted				Boom Mounted – Braden CH210			
Rope Layer	Line Speed Feet Per Minute	Single Line Pull	Total Rope Length	Rope Layer	Line Speed Feet Per Minute	Single Line Pull	Total Rope Length
1st*	129	37.655	64	1st*	193	19.100	116
2nd*	140	34.725	129	2nd*	210	17.530	242
3rd*	150	32.210	204	3rd*	227	16.200	379
4th*	161	30.050	278	4th*	244	15.050	526
5th*	172	28.155	364	5th*	262	14.060	683
6th*	183	26.480	449	6th**	279	13.190	851
7th*	194	25.000	545				
8th**	205	23.680	640				
9th**	216	22.465	747				

**Remarks**

\* Working Layers

\*\* Storage Layers

**TRANSPORT EXAMPLE FOR HC 165**

**240' 77" SH BOOM WITH OFFSET TIP 80' 16HL JIB**

Loads required as follows: (weights shown do **NOT** include blocking or tie-down material)

<b>LOAD NO. 1</b>	
Crawler side frame .....	37,000 lb
2 x 20' 16HL center sections @ 510 lb each .....	1,020 lb
<b>TOTAL LOAD</b> .....	<b>38,020 lb</b>
<b>LOAD NO. 2</b>	
Crawler side frame .....	37,000 lb
Basic 40' of 16HL Jib .....	3,060 lb
<b>TOTAL LOAD</b> .....	<b>40,060 lb</b>
<b>LOAD NO. 3</b>	
2 x counterweights @ 9,200 lb each .....	18,400 lb
1 x 50' boom center section .....	4,500 lb
<b>TOTAL LOAD</b> .....	<b>22,900 lb</b>
<b>LOAD NO. 4</b>	
2 x counterweights @ 11,200 lb each .....	22,400 lb
1 x 50' boom center section .....	4,500 lb
<b>TOTAL LOAD</b> .....	<b>26,900 lb</b>
<b>LOAD NO. 5</b>	
2 x counterweights @ 11,200 lb each .....	22,400 lb
1 x 50' boom center section .....	4,500 lb
<b>TOTAL LOAD</b> .....	<b>26,900 lb</b>
<b>LOAD NO. 6</b>	
Base counterweight .....	39,000 lb
1 x 20' boom (outer base) .....	2,900 lb
<b>TOTAL LOAD</b> .....	<b>41,900 lb</b>
<b>LOAD NO. 7</b>	
Miscellaneous, Block, Ball, Pendants, etc. ....	12,000 lb
1 x 30' offset tip .....	5,300 lb
1 x 10' boom center section .....	1,000 lb
<b>TOTAL LOAD</b> .....	<b>18,300 lb</b>
<b>LOAD NO. 8</b>	
<b>Upperworks and Carbody:</b>	
a) Transport system	
b) Boom inner section and boom stops	
c) Boom hoist rope	
d) Wire rope on main and auxiliary drums	
<b>TOTAL WEIGHT OF UPPER, etc.</b> .....	<b>94,000 lb</b>

**KEY**

 Counterweight



The information contained in this brochure merely consists of general descriptions and a broad compilation of performance features which might not apply precisely as described under specific application conditions or which may change as a result of further product development. The desired performance features only become binding once expressly agreed in the final contract.

Note: Data published herein is intended as a guide only and shall not be construed to warrant applicability for lifting purposes. Crane operation is subject to the computer charts and operation manual both supplied with the crane.

Subject to change without notice.

02/05

**Terex Cranes Wilmington Operations**

Mobile hydraulic and lattice-boom cranes  
202 Raleigh St. · Wilmington, NC 28412 USA  
Phone +1 910 395 8500 · Fax +1 910 395 8538  
Email: [american@american-crane.com](mailto:american@american-crane.com)