

# Specifications

MODELS	SLC™-12		SLC™-18		SLC™-24	
MEASUREMENTS	Metric	US	Metric	US	Metric	US
<b>Working height:</b>						
standard forks - forks down	3.40 m	11 ft 2 in	5.10 m	16 ft 9 in	6.78 m	22 ft 3 in
standard forks - forks up	3.94 m	12 ft 11 in	5.64 m	18 ft 6 in	7.32 m	24 ft
adjustable forks - forks down	3.40 m	11 ft 2 in	5.10 m	16 ft 9 in	6.78 m	22 ft 3 in
adjustable forks - forks up	3.94 m	12 ft 11 in	5.64 m	18 ft 6 in	7.32 m	24 ft
boom**	3.70 m	12 ft 2 in	5.41 m	17 ft 9 in	7.10 m	23 ft 3 in
<b>A</b> Height - stowed	2.18 m	7 ft 2 in	2.18 m	7 ft 2 in	2.18 m	7 ft 2 in
<b>B</b> Length - stowed	86 cm	2 ft 10 in	86 cm	2 ft 10 in	86 cm	2 ft 10 in
<b>C</b> - operating	1.60 m	5 ft 3 in	1.85 m	6 ft 1 in	2.06 m	6 ft 9 in
<b>D</b> Width - stowed*	80 cm	2 ft 7.5 in	80 cm	2 ft 7.5 in	80 cm	2 ft 7.5 in
- with stabilisers lowered	1.68 m	5 ft 6 in	1.68 m	5 ft 6 in	1.68 m	5 ft 6 in

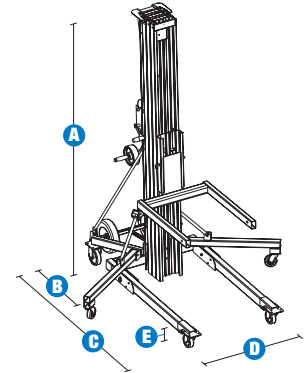

<b>PRODUCTIVITY</b>						
<b>Load capacity:</b>						
36 cm (14 in) load centre	295 kg	650 lbs	295 kg	650 lbs	295 kg	650 lbs
61 cm (24 in) load centre	193 kg	425 lbs	193 kg	425 lbs	193 kg	425 lbs
1.07 m (42 in) load centre	82 kg	180 lbs	73 kg	160 lbs	73 kg	160 lbs
<b>E</b> Ground clearance	5 cm	2 in	5 cm	2 in	5 cm	2 in
Load height minimum	15 cm	6 in	15 cm	6 in	15 cm	6 in

<b>POWER</b>						
<b>Average cranks:</b>						
standard winch	27.8 cranks/m	8.5 cranks/ft	27.8 cranks/m	8.5 cranks/ft	27.8 cranks/m	8.5 cranks/ft
two speed winch, high	13.1 cranks/m	4 cranks/ft	13.1 cranks/m	4 cranks/ft	13.1 cranks/m	4 cranks/ft
two speed winch, low	49.2 cranks/m	15 cranks/ft	49.2 cranks/m	15 cranks/ft	49.2 cranks/m	15 cranks/ft

<b>WEIGHT</b>						
	102 kg	225 lbs	139 kg	307 lbs	157 kg	347 lbs

<b>LOAD HANDLING ATTACHMENTS</b>						
MEASUREMENTS	Metric	US	Weight - Metric	Weight - US		
Standard forks (l/w/d)***	71/58/6 cm	28/23/2.5 in	12 kg	26.5 lbs.		
Adjustable forks (l/w/d)***	70/30-76/6 cm	27.5/12-30/2.5 in	24 kg	52.5 lbs.		
Fork extensions detached (each) (l/w/d)***	76/5/8 cm	30/2/3 in	2 kg	4.5 lbs		
Fork extensions attached (each) (l/w/d)***	64/5/8 cm	25/2/3 in	2 kg	4.5 lbs		
Boom (l/w/d)***	46-107/4/15 cm	18-42/1.5/6 in	18 kg	39.9 lbs		
Pipe cradle (l/w/d)***/*	69/61/15.2 cm	27/24/6 in	4.5 kg	10 lbs		
Load platform (l/w/d)***	67/58/6 cm	26.3/23/2.5 in	14 kg	31.5 lbs		

\* Outside dimensions.  
\*\* Measured from ground to bottom of shackle.  
\*\*\* Length/Width/Depth.  
\*\*\*\* Handles round objects up to 76 cm (30 in) in diameter.

## Features

### EASILY CONFIGURED TO MEET YOUR NEEDS

#### PLATFORM OPTIONS

- Boom
- Standard forks
- Adjustable forks
- Fork extensions
- Pipe cradle
- Load platform

#### POWER OPTIONS

- One speed winch
- Two speed winch

#### BASE OPTIONS

- Standard base
- Stabiliser set

### STANDARD FEATURES

#### MEASUREMENTS

##### SLC™-12

- 3.94 m (12 ft 11 in) maximum working height
- Up to 295 kg (650 lb) lift capacity

##### SLC™-18

- 5.64 m (18 ft 6 in) maximum working height
- Up to 295 kg (650 lb) lift capacity

##### SLC™-24

- 7.32 m (24 ft) maximum working height
- Up to 295 kg (650 lb) lift capacity

#### PRODUCTIVITY

- Standard forks
- Heavy-duty design
- Strong, lightweight aluminium telescoping mast
- Single door access
- Quick set up requires no tools
- Interchangeable load handling attachments
- Non-marking 10 cm (4 in) front casters and 13 cm (5 in) rear casters with side brakes
- Rear transport wheel assembly
- Glide rails allow easy loading and unloading, on or off a vehicle, for transport

### STANDARD FEATURES cont.

#### PRODUCTIVITY cont.

- Hold-down bar secures mast assembly during transport
- Captive stabiliser set (standard on SLC™-18, -24)
- Mast brake

#### POWER

- One speed winch



### OPTIONS & ACCESSORIES

#### PRODUCTIVITY

- Boom
- Adjustable forks
- Fork extensions
- Pipe cradle
- Load platform
- Stabiliser set (option on SLC™-12)

#### POWER

- Two speed winch

#### UK

Millennium House  
Brunel Drive  
Newark NG24 2DE  
UK  
Tel: +44 (0)1476 584333  
Fax: +44 (0)1476 584334

#### France

10, ZA de la Croix St. Mathieu  
28320 Gallardon  
France  
Tel: +33 (0)2 37 26 09 99  
Fax: +33 (0)2 37 26 09 98

#### Germany

Finienweg 3  
28832 Achim/Bremen  
Germany  
Tel: +49 (0)4202 8852-0  
Fax: +49 (0)4202 8852-25

#### Spain

Gaià 31, Pol. Ind. Plá d'en Coll  
08110 Montcada i Reixac  
Barcelona  
Spain  
Tel: +34 93 572 50 90  
Fax: +34 93 572 50 91

#### Scandinavia

Importgatan 17  
422 46 Hisings Backa  
Sweden  
Tel: +46 31 57 51 00  
Fax: +46 31 57 90 20

#### Middle East

Terex Middle East  
PO Box 282325, Dubai  
U.A.E.  
Tel: +971 4 339 1800  
Fax: +971 4 339 1802  
Email: InfoME@terex.com

#### Genie United States

18340 NE 76th Street  
P.O. Box 97030  
Redmond, WA  
USA 98073-9730  
Tel: +1 425 881-1800  
Fax: +1 425 883-3475

**Email:** AWP-InfoEurope@terex.com

#### Distributed By: