



TEREX | AMERICAN

HC 80 | Hydraulic Crawler Crane 80 t Lifting Capacity



HC 80

HYDRAULIC CRAWLER CRANE

HC 80

HIGHLIGHTS

- ▶ 80 (73 mt) tons maximum lifting capacity
- ▶ 200 ft (61 m) maximum length of main boom
- ▶ 170 + 60 ft (52 + 18 m) maximum boom and jib
- ▶ 240 ft (73 m) max. boom and luffing jib length
- ▶ Power up/down and freefall on main, auxiliary and optional third drum
- ▶ Quiet, spacious operator's cab
- ▶ Excellent visibility
- ▶ Two speed travel
- ▶ Superior transportability – 88,000 lb (39 917 kg) transport weight includes side-frames and boom inner

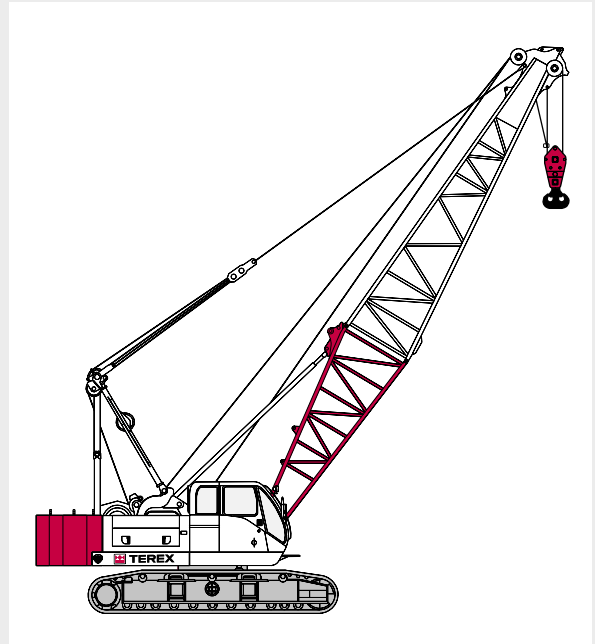

CONTENTS

Page:

Specifications

Dimensions	4
------------------	---

Main boom

Range Diagram, 47HI Boom	6
With 47HI Offset Tip Boom and 58,100 Pound Counterweight	7
Range Diagram, 46HI Boom	11
With 46HI Angle Boom, 4 Sheave Tip and 58,100 Pound Counterweight	12

Jib

Range diagram, 47HI Boom, #9HL Jib	16
With 47HI Boom, #9HL Jib and 58,100 Pound Counterweight	17
Range diagram, 46 HI Boom, #9 Angle Jib	21
With 46HI Boom, #9 Angle Jib and 58,100 Pound Counterweight	22

Technical description

Hydraulic Crawler Crane	28
-------------------------------	----

Transport example for HC 80

.....	29
-------	----

DIMENSIONS

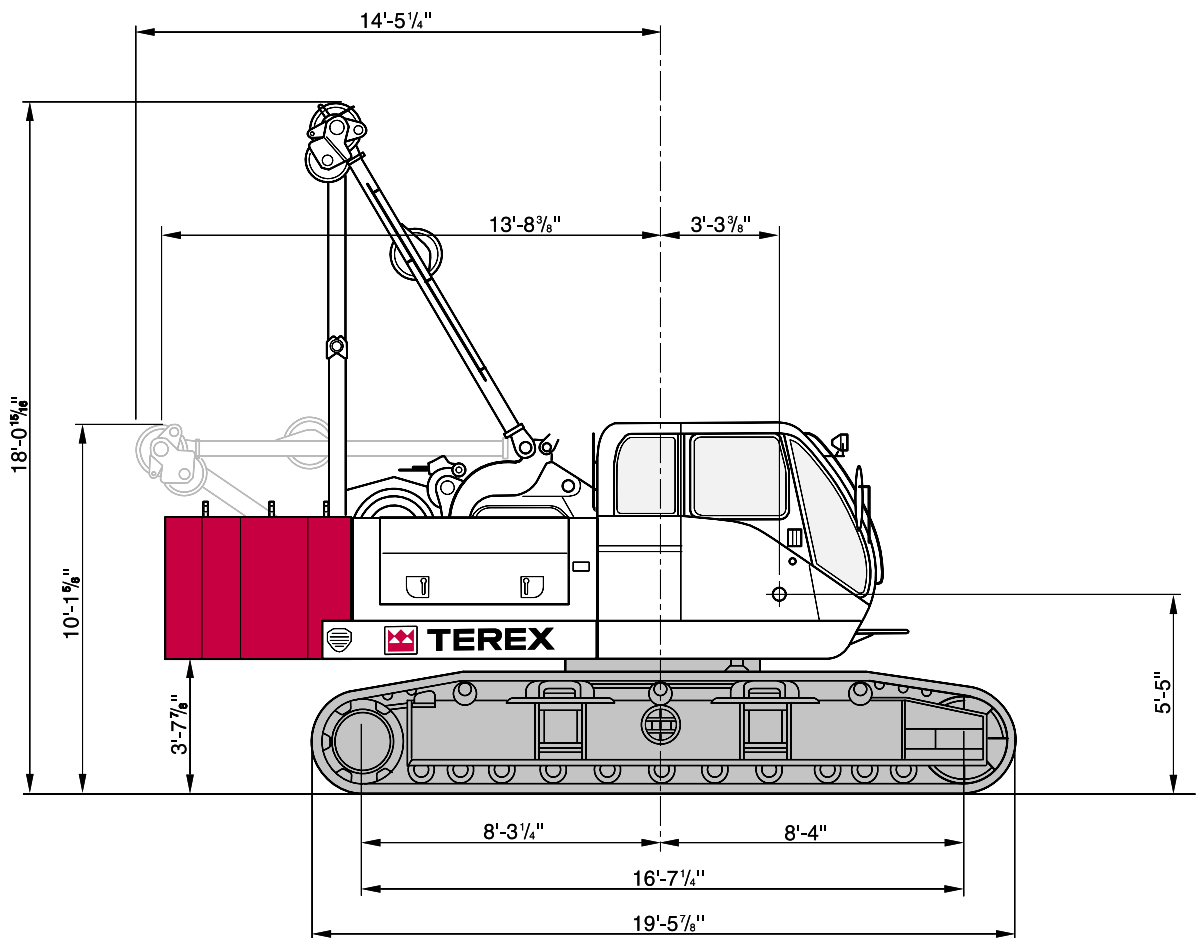

DIMENSIONS

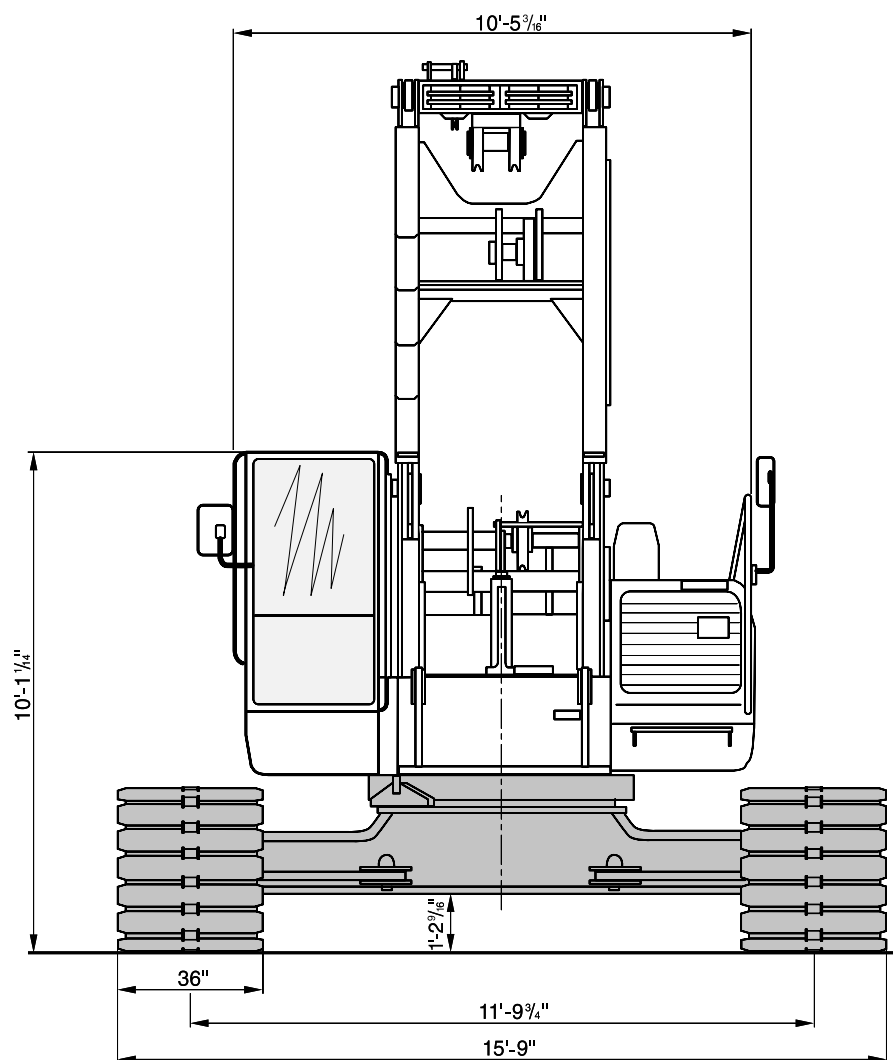

RANGE DIAGRAM, 47HI BOOM

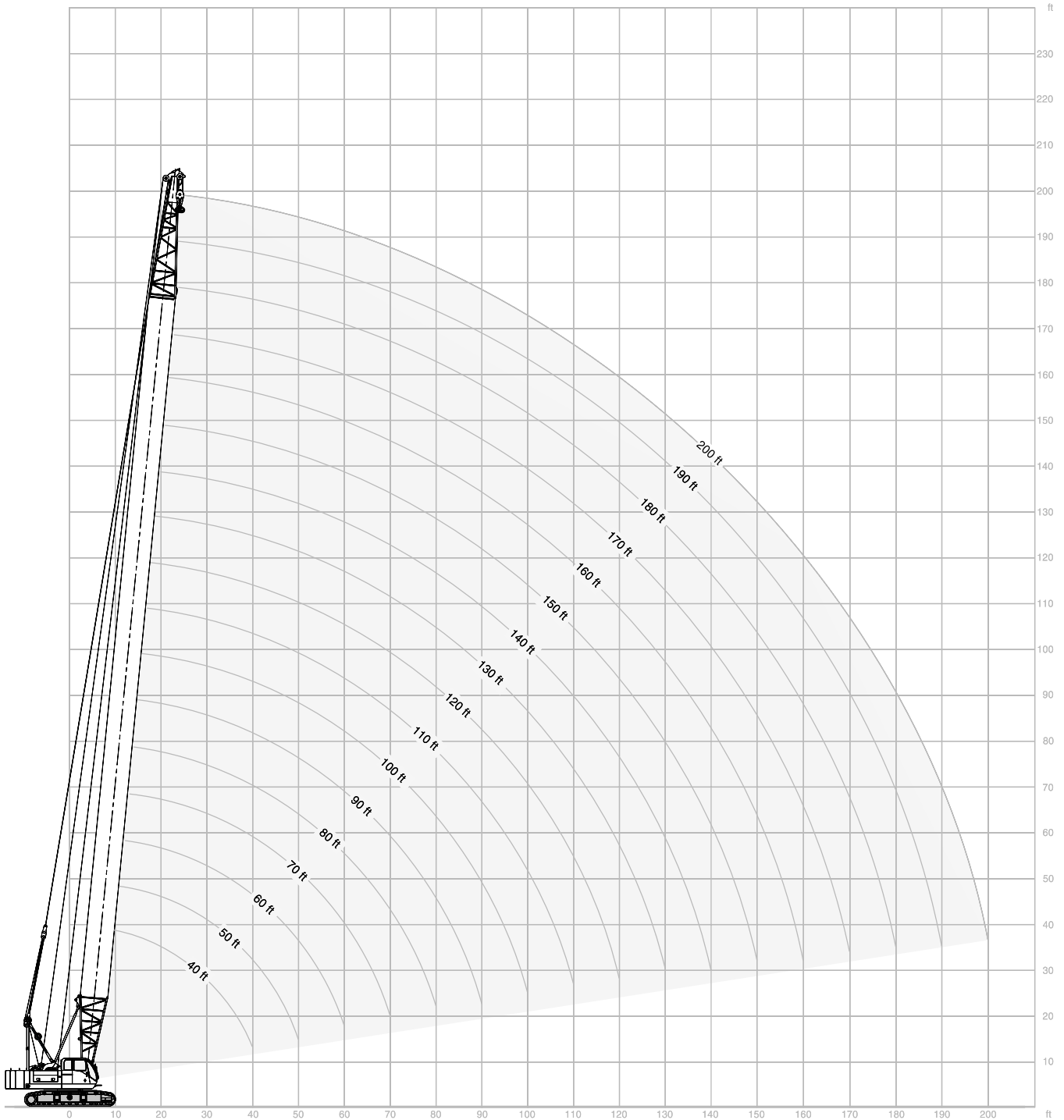

WITH 47HI OFFSET TIP BOOM

 58,100 lb

360°

ANSI B 30.5

40' (12.2 m) Boom length			
Radius (Feet)	Boom Angle (Degrees)	Side Frames Extended (Pounds)	From Boom Pt. to Ground (Feet)
11	80.5	160,000*	45
12	79.0	160,000*	45
15	74.6	141,480	44
20	67.0	87,810	42
25	58.8	63,360	40
30	49.9	49,350	36
35	39.5	40,320	31
40	25.8	33,970	23

50' (15.2 m) Boom length			
Radius (Feet)	Boom Angle (Degrees)	Side Frames Extended (Pounds)	From Boom Pt. to Ground (Feet)
13	80.1	160,000*	55
15	77.8	141,440	54
20	71.8	87,750	53
25	65.6	63,280	51
30	59.1	49,250	48
35	52.0	40,220	45
40	44.2	33,860	40
50	22.9	25,540	25

60' (18.3 m) Boom length			
Radius (Feet)	Boom Angle (Degrees)	Side Frames Extended (Pounds)	From Boom Pt. to Ground (Feet)
14	80.8	145,370*	65
15	79.8	141,380	64
20	74.9	87,660	63
25	69.9	63,170	62
30	64.7	49,120	60
35	59.2	40,100	57
40	53.4	33,730	54
50	40.2	25,400	44
60	20.8	20,230	27

70' (21.3 m) Boom length			
Radius (Feet)	Boom Angle (Degrees)	Side Frames Extended (Pounds)	From Boom Pt. to Ground (Feet)
16	80.5	125,040*	74
20	77.1	87,590	74
25	72.9	63,090	72
30	68.5	49,040	71
35	64.0	40,020	68
40	59.3	33,640	66
50	49.2	25,310	58
60	37.0	20,150	48
70	19.2	16,580	28

80' (24.4 m) Boom length			
Radius (Feet)	Boom Angle (Degrees)	Side Frames Extended (Pounds)	From Boom Pt. to Ground (Feet)
17	80.9	109,250*	84
20	78.8	87,470	84
25	75.1	62,960	83
30	71.3	48,880	81
35	67.5	39,870	79
40	63.5	33,480	77
50	55.1	25,140	71
60	45.8	20,000	63
70	34.5	16,430	51
80	17.9	13,830	30

90' (27.4 m) Boom length			
Radius (Feet)	Boom Angle (Degrees)	Side Frames Extended (Pounds)	From Boom Pt. to Ground (Feet)
19	80.7	94,540	94
20	80.0	87,330	94
25	76.8	62,810	93
30	73.5	48,720	92
35	70.1	39,720	90
40	66.7	33,320	88
50	59.5	24,970	83
60	51.7	19,840	76
70	43.0	16,260	67
80	32.5	13,660	54
90	16.9	11,690	32

100' (30.5 m) Boom length			
Radius (Feet)	Boom Angle (Degrees)	Side Frames Extended (Pounds)	From Boom Pt. to Ground (Feet)
21	80.4	80,910	104
25	78.1	62,690	103
30	75.2	48,580	102
35	72.2	39,590	101
40	69.1	33,190	99
50	62.8	24,840	94
60	56.1	19,720	88
70	48.9	16,130	81
80	40.7	13,540	71
90	30.7	11,560	56
100	16.0	10,010	33

110' (33.5 m) Boom length			
Radius (Feet)	Boom Angle (Degrees)	Side Frames Extended (Pounds)	From Boom Pt. to Ground (Feet)
22	80.8	72,040*	114
25	79.2	62,530	113
30	76.5	48,420	112
35	73.8	39,430	111
40	71.1	33,020	109
50	65.5	24,650	105
60	59.6	19,560	100
70	53.3	15,970	94
80	46.4	13,360	85
90	38.7	11,380	74
100	29.2	9,840	59
110	15.2	8,590	34

KEY

 Counterweight

CB Central ballast

WITH 47HI OFFSET TIP BOOM

58,100 lb

360°

ANSI B 30.5

120' (36.6 m) Boom length

Radius (Feet)	Boom Angle (Degrees)	Side Frames Extended (Pounds)	From Boom Pt. to Ground (Feet)
24	80.6	60,160 *	124
25	80.1	60,160 *	124
30	77.7	48,260	123
35	75.2	39,260	121
40	72.7	32,850	120
50	67.6	24,470	116
60	62.3	19,390	112
70	56.8	15,800	106
80	50.8	13,190	98
90	44.3	11,210	89
100	37.0	9,660	78
110	28.0	8,410	62
120	14.5	7,390	36

130' (39.6 m) Boom length

25	80.9	50,970 *	134
30	78.6	48,100	133
35	76.4	39,120	132
40	74.1	32,700	130
50	69.4	24,320	127
60	64.7	19,240	123
70	59.6	15,650	118
80	54.4	13,040	111
90	48.7	11,060	103
100	42.5	9,510	93
110	35.4	8,250	81
120	26.8	7,230	64
130	13.9	6,380	37

140' (42.7 m) Boom length

27	80.7	42,380 *	144
30	79.5	42,370 *	143
35	77.4	38,950	142
40	75.3	32,530	141
50	71.0	24,140	138
60	66.6	19,070	134
70	62.0	15,480	129
80	57.3	12,860	123
90	52.2	10,880	116
100	46.8	9,330	108
110	40.9	8,070	97
120	34.1	7,040	84
130	25.8	6,180	66
140	13.4	5,470	38

150' (45.7 m) Boom length

Radius (Feet)	Boom Angle (Degrees)	Side Frames Extended (Pounds)	From Boom Pt. to Ground (Feet)
28	80.9	36,630 *	154
30	80.2	36,540 *	153
35	78.2	36,070 *	152
40	76.3	32,360	151
50	72.3	23,960	148
60	68.2	18,900	145
70	64.0	15,310	140
80	59.7	12,690	135
90	55.1	10,710	128
100	50.3	9,150	121
110	45.1	7,890	112
120	39.4	6,860	101
130	32.9	6,000	87
140	24.9	5,270	69
150	12.9	4,650	39

160' (48.8 m) Boom length

30	80.8	31,770 *	163
35	79.0	31,370 *	162
40	77.1	30,790 *	161
50	73.4	23,800	159
60	69.7	18,750	155
70	65.8	15,150	151
80	61.8	12,530	146
90	57.6	10,550	141
100	53.2	8,990	134
110	48.6	7,730	125
120	43.6	6,690	116
130	38.1	5,830	104
140	31.8	5,100	90
150	24.1	4,480	71
160	12.5	3,950	40

170' (51.8 m) Boom length

31	81.0	27,710 *	173
35	79.6	27,340 *	173
40	77.9	26,810 *	172
50	74.4	23,610	169
60	70.9	18,580	166
70	67.3	14,980	162
80	63.6	12,360	158
90	59.7	10,360	152
100	55.7	8,800	146
110	51.5	7,540	139
120	47.1	6,510	130
130	42.2	5,650	120
140	36.9	4,920	108
150	30.8	4,290	93
160	23.4	3,750	73
170	12.1	3,290	41

WITH 47HI OFFSET TIP BOOM

58,100 lb

360°

ANSI B 30.5

180' (54.9 m) Boom length			
Radius (Feet)	Boom Angle (Degrees)	Side Frames Extended (Pounds)	From Boom Pt. to Ground (Feet)
33	80.9	24,240 *	183
35	80.2	24,110 *	183
40	78.6	23,210 *	182
50	75.3	20,080 *	180
60	72.0	18,410	177
70	68.6	14,800	173
80	65.1	12,180	169
90	61.6	10,190	164
100	57.9	8,630	158
110	54.0	7,360	151
120	50.0	6,330	143
130	45.7	5,460	134
140	41.0	4,720	123
150	35.8	4,100	111
160	29.9	3,550	95
170	22.7	3,080	75
180	11.8	2,690	42

200' (61.0 m) Boom length			
Radius (Feet)	Boom Angle (Degrees)	Side Frames Extended (Pounds)	From Boom Pt. to Ground (Feet)
36	80.9	16,750 *	203
40	79.7	16,230 *	202
50	76.8	15,000 *	200
60	73.8	13,800 *	198
70	70.8	12,770 *	194
80	67.8	11,840	191
90	64.6	9,840	186
100	61.4	8,270	181
110	58.1	7,010	175
120	54.6	5,970	169
130	51.0	5,100	161
140	47.2	4,370	152
150	43.2	3,740	142
160	38.8	3,190	131
170	33.9	2,710	117
180	28.4	2,300	100
190	21.5	1,940	79
200	11.2	1,560 *	44

190' (57.9 m) Boom length			
Radius (Feet)	Boom Angle (Degrees)	Side Frames Extended (Pounds)	From Boom Pt. to Ground (Feet)
35	80.7	19,320 *	193
40	79.2	18,660 *	192
50	76.1	17,360 *	190
60	73.0	16,110 *	187
70	69.8	14,640	184
80	66.5	12,010	180
90	63.2	10,020	175
100	59.8	8,460	170
110	56.2	7,200	163
120	52.5	6,160	156
130	48.5	5,290	148
140	44.4	4,550	138
150	39.8	3,930	127
160	34.8	3,390	114
170	29.1	2,910	98
180	22.1	2,500	77
190	11.5	2,150	43



NOTES TO LIFTING CAPACITY

⚠ Warning

This rating chart is invalid if the crane has been modified or altered by use of other than GENUINE AMERICAN PARTS as such modifications or alterations may affect its capacity or safe operation. See American Crane Corporation Service Bulliten #259.

Ratings in this chart are in POUNDS and do not exceed the percentage of tipping specified for this crane by ANSI B30.5. All ratings require that the crane be standing level on a firm uniformly supporting surface.

Do not lift loads in excess of those shown on this chart. Lifting loads in excess of those shown or operation not in accordance with good operating practice, including limitations shown on page 3499 of Operator's Manual, can cause tipping, structural damage or catastrophic failure.

Asterisk (*) areas on this chart indicate ratings which are limited by strength of material or factors other than stability (tipping).

„RADIUS IN FEET“ is the horizontal distance at ground level from the crane centerline of rotation to a vertical line through the center of gravity of the suspended load.

When using the main boom fall with jib in place, the main fall ratings must be reduced by the jib effective weight shown on the jib rating chart plus twice the weight of all suspended blocks, slings, rope, etc., at the jib fall. See Appendix A.

When using the main boom fall with boom tip extension in place, the main fall ratings must be reduced by the weight of the boom tip extension plus twice the weight of all suspended blocks, slings, rope, etc., at the boom tip extension fall. See Appendix A.

Blocks, slings, buckets and other load carrying devices are considered part of the load. The weight of standard hoisting ropes for the rating at a given radius has been calculated as part of the boom point load and need not be considered in determining net allowable loads. See Appendix A.

This chart was developed exclusively for use with a boom only. Under no circumstances are these ratings to be interpreted for use with a jib.

Ratings shown on this chart make no allowance for such factors as out of plumb loads, wind, poor soil conditions, improper inflation of rubber tires and dynamic effects due to excessive operating speeds. The user (operator) must exercise judgement to make allowance for these conditions. See page 3499 of Operator's Manual for detailed information.

No account is taken of the wind force on the load. This effect, which can be substantial for loads with large surface areas, must be considered by the user. In any wind it is strongly recommended that taglines be used to control the load.

BOOM HOIST LINE is 14 parts of 5/8 inch diameter EIPS wire rope with a minimum breaking strength of 41,200 pounds.

PENDANT SUSPENSION LINE is 2 parts of 1-1/4 inch diameter MONOLAY wire rope with a minimum breaking strength of 172,800 pounds.

MAIN LOAD LINE is 7/8 inch diameter EIPS wire rope with a minimum breaking strength of 79,600 pounds.

ERECTION

Erection is with the A-Frame fully raised. Erection „OVER THE END“ is with the boom over the idler end. Erection „OVER THE SIDE“ is with the boom 90° to the sideframes and with the side frames extended. Blocks, slings and other load carrying devices must be on the ground during erection.

MAXIMUM BOOM & JIB SELF-ERECTION DATA		
	OVER THE END & OVER THE SIDE	
	BOOM LENGTH (FEET)	JIB LENGTH (FEET)
#7HL JIB	200 170	0 60
#9HL JIB	200 170	0 60

47HI BOOM COMPOSITION CHART					
BOOM LENGTH (FEET)	BOOM SECTIONS				
	20' 47HI INNER	10' 47H CENTER	20' 47H CENTER	30' 47H CENTER	20' 47H or 47HI OUTER
40	1	0	0	0	1
50	1	1	0	0	1
60	1	0	1	0	1
70	1	0	0	1	1
80	1	1	0	1	1
90	1	0	1	1	1
100	1	0	0	2	1
110	1	1	0	2	1
120	1	0	1	2	1
130	1	0	0	3	1
140	1	1	0	3	1
150	1	0	1	3	1
160	1	0	0	4	1
170	1	1	0	4	1
180	1	0	1	4	1
190	1	0	0	5	1
200	1	1	0	5	1

LOAD HOISTING INFORMATION - 7/8 inch diameter EIPS wire rope			
MAXIMUM LIFTING CAPACITY - LBS.	MINIMUM PARTS OF LINE	MAXIMUM HOISTING DISTANCE - FEET	
		MAIN - (RIGHT)	AUX. - (LEFT)
160,000	8	73	73
159,180	7	84	84
136,440	6	98	98
113,700	5	117	117
90,960	4	147	147
68,220	3	196	196
45,480	2	294	294
22,740	1	588	588

RANGE DIAGRAM, 46HI BOOM

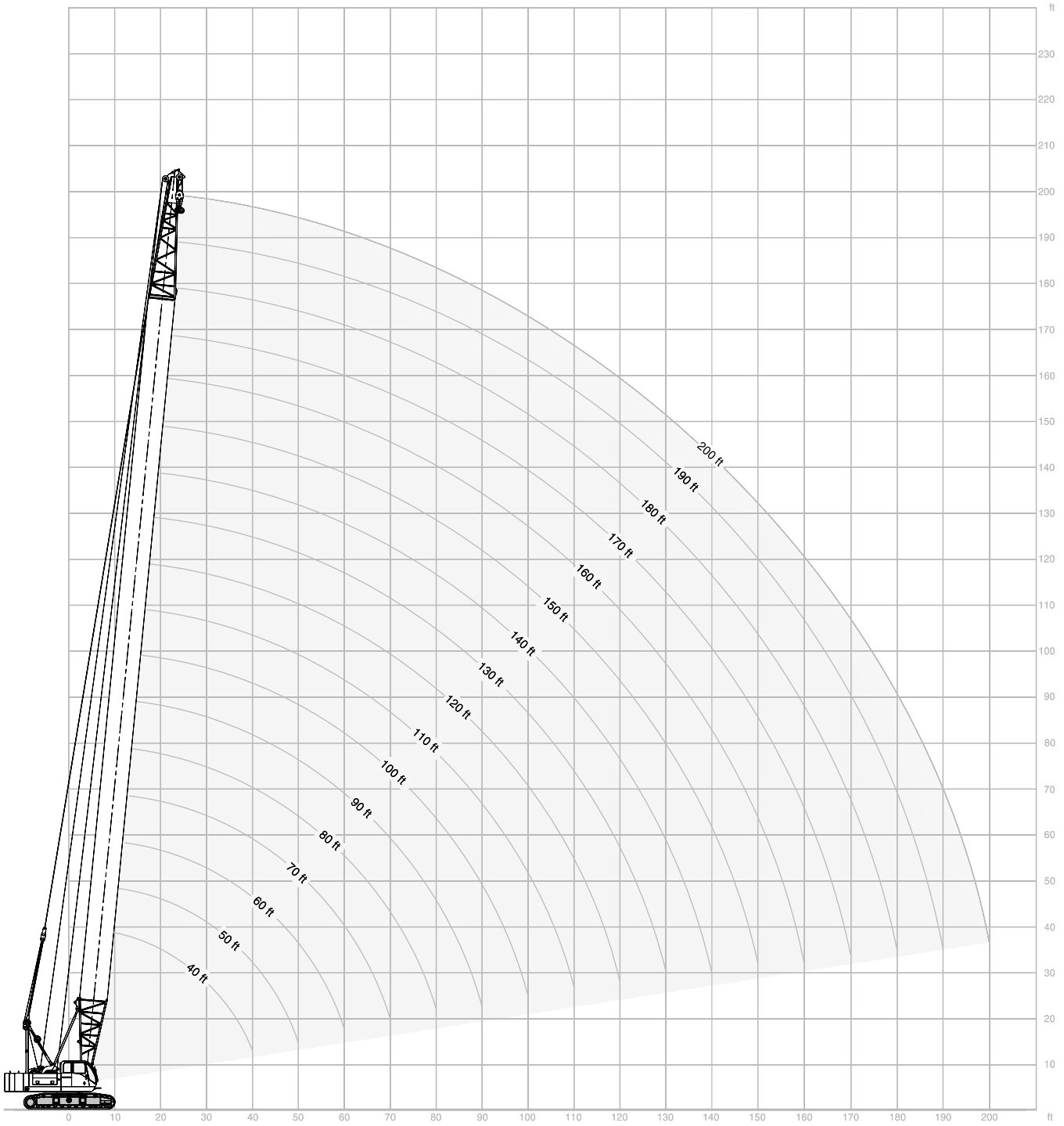

WITH 46HI ANGLE BOOM, 4 SHEAVE TIP

58,100 lb

360°

ANSI B 30.5

40' (12.2 m) Boom length			
Radius (Feet)	Boom Angle (Degrees)	360 Degree Rating (Pounds)	From Boom Pt. to Ground (Feet)
10	80.9	160,000 *	45
12	77.9	160,000 *	45
15	73.5	141,160	44
20	65.9	87,490	42
25	57.7	63,040	39
30	48.8	49,030	36
35	38.4	40,000	30
40	24.7	33,650	22

50' (15.2 m) Boom length			
Radius (Feet)	Boom Angle (Degrees)	360 Degree Rating (Pounds)	From Boom Pt. to Ground (Feet)
12	80.4	138,490 *	55
15	76.9	128,430 *	54
20	70.9	87,390	53
25	64.7	62,910	51
30	58.2	48,880	48
35	51.2	39,850	44
40	43.4	33,490	40
45	34.2	28,790	34
50	22.0	25,180	24

60' (18.3 m) Boom length			
Radius (Feet)	Boom Angle (Degrees)	360 Degree Rating (Pounds)	From Boom Pt. to Ground (Feet)
14	80.1	119,630 *	65
15	79.1	117,070 *	64
20	74.2	87,280	63
25	69.2	62,790	61
30	64.0	48,740	59
35	58.5	39,710	57
40	52.7	33,340	53
45	46.4	28,630	49
50	39.4	25,020	44
55	31.1	22,200	36
60	20.1	19,860	26

70' (21.3 m) Boom length			
Radius (Feet)	Boom Angle (Degrees)	360 Degree Rating (Pounds)	From Boom Pt. to Ground (Feet)
15	80.7	106,350 *	74
20	76.5	87,110	73
25	72.2	62,610	72
30	67.9	48,550	70
35	63.4	39,530	68
40	58.7	33,150	65
45	53.8	28,440	62
50	48.5	24,820	58
55	42.8	22,000	53
60	36.4	19,660	47
65	28.8	17,720	39
70	18.6	16,100	28

80' (24.4 m) Boom length			
Radius (Feet)	Boom Angle (Degrees)	Side Frames Extended (Pounds)	From Boom Pt. to Ground (Feet)
17	80.4	94,370 *	84
20	78.2	87,000	84
25	74.5	62,490	83
30	70.8	48,410	81
35	66.9	39,400	79
40	63.0	33,020	77
45	58.9	28,300	74
50	54.6	24,670	71
55	50.1	21,870	67
60	45.2	19,540	62
65	39.9	17,600	57
70	34.0	15,970	50
75	26.9	14,570	42
80	17.4	13,370	29

90' (27.4 m) Boom length			
Radius (Feet)	Boom Angle (Degrees)	Side Frames Extended (Pounds)	From Boom Pt. to Ground (Feet)
18	80.8	84,440 *	94
20	79.5	82,260 *	94
25	76.3	62,300	93
30	73.0	48,210	91
35	69.6	39,200	90
40	66.2	32,810	88
45	62.7	28,090	85
50	59.0	24,460	83
55	55.2	21,680	79
60	51.2	19,330	76
65	47.0	17,390	71
70	42.5	15,760	66
75	37.5	14,360	60
80	32.0	13,160	53
85	25.3	12,110	44
90	16.4	11,200	31

100' (30.5 m) Boom length			
Radius (Feet)	Boom Angle (Degrees)	Side Frames Extended (Pounds)	From Boom Pt. to Ground (Feet)
20	80.6	75,930 *	104
25	77.7	62,120	103
30	74.7	48,010	102
35	71.7	39,020	100
40	68.7	32,620	99
45	65.6	27,890	96
50	62.4	24,260	94
55	59.1	21,490	91
60	55.7	19,140	88
65	52.2	17,200	84
70	48.4	15,570	80
75	44.5	14,170	75
80	40.2	12,960	70
85	35.6	11,910	64
90	30.3	10,990	56
95	24.0	10,170	46
100	15.5	9,450	32

WITH 46HI ANGLE BOOM, 4 SHEAVE TIP

58,100 lb

360°

ANSI B 30.5

110' (33.5 m) Boom length			
Radius (Feet)	Boom Angle (Degrees)	Side Frames Extended (Pounds)	From Boom Pt. to Ground (Feet)
21	80.9	68,930*	114
25	78.8	61,920	113
30	76.1	47,800	112
35	73.4	38,810	111
40	70.7	32,400	109
45	67.9	27,680	107
50	65.1	24,030	105
55	62.2	21,280	103
60	59.2	18,940	100
65	56.1	16,990	97
70	52.9	15,350	93
75	49.6	13,950	89
80	46.0	12,750	85
85	42.3	11,700	79
90	38.3	10,760	74
95	33.8	9,950	67
100	28.8	9,220	58
105	22.9	8,570	48
110	14.8	7,980	33

120' (36.6 m) Boom length			
Radius (Feet)	Boom Angle (Degrees)	Side Frames Extended (Pounds)	From Boom Pt. to Ground (Feet)
23	80.7	61,380*	124
25	79.7	60,000*	123
30	77.3	47,630	122
35	74.8	38,640	121
40	72.4	32,230	120
45	69.8	27,500	118
50	67.3	23,850	116
55	64.7	21,120	114
60	62.0	18,760	111
65	59.2	16,820	109
70	56.4	15,180	105
75	53.5	13,780	102
80	50.5	12,570	98
85	47.3	11,520	94
90	44.0	10,590	89
95	40.4	9,770	83
100	36.6	9,040	77
105	32.4	8,380	70
110	27.6	7,790	61
115	21.9	7,260	50
120	14.2	6,780	35

130' (39.6 m) Boom length			
Radius (Feet)	Boom Angle (Degrees)	Side Frames Extended (Pounds)	From Boom Pt. to Ground (Feet)
24	81.0	55,570*	134
25	80.6	55,210*	134
30	78.3	47,410	133
35	76.0	38,430	132
40	73.8	32,020	130
45	71.4	27,280	129
50	69.1	23,630	127
55	66.7	20,900	125
60	64.3	18,560	123
65	61.8	16,610	120
70	59.3	14,960	117
75	56.7	13,570	114
80	54.0	12,350	111
85	51.3	11,300	107
90	48.4	10,370	103
95	45.3	9,550	98
100	42.2	8,820	93
105	38.8	8,160	87
110	35.1	7,570	80
115	31.1	7,030	72
120	26.5	6,540	63
125	21.0	6,100	52
130	13.6	5,700	36

140' (42.7 m) Boom length			
Radius (Feet)	Boom Angle (Degrees)	Side Frames Extended (Pounds)	From Boom Pt. to Ground (Feet)
26	80.8	49,960*	144
30	79.2	47,210	143
35	77.1	38,230	142
40	74.9	31,810	141
45	72.8	27,070	139
50	70.7	23,420	138
55	68.5	20,710	136
60	66.3	18,350	134
65	64.0	16,400	131
70	61.7	14,760	129
75	59.4	13,360	126
80	57.0	12,140	123
85	54.5	11,090	119
90	51.9	10,170	116
95	49.3	9,340	111
100	46.5	8,610	107
105	43.6	7,940	102
110	40.6	7,350	96
115	37.3	6,820	90
120	33.8	6,330	83
125	29.9	5,880	75
130	25.5	5,480	66
135	20.2	5,100	54
140	13.1	4,760	37

WITH 46HI ANGLE BOOM, 4 SHEAVE TIP

58,100 lb

360°

ANSI B 30.5

150' (45.7 m) Boom length			
Radius (Feet)	Boom Angle (Degrees)	Side Frames Extended (Pounds)	From Boom Pt. to Ground (Feet)
28	80.7	43,920 *	153
30	79.9	43,170 *	153
35	77.9	38,020	152
40	76.0	31,590	151
45	74.0	26,850	150
50	72.0	23,190	148
55	70.0	20,490	146
60	67.9	18,130	144
65	65.9	16,190	142
70	63.8	14,540	140
75	61.6	13,130	137
80	59.4	11,930	135
85	57.2	10,870	131
90	54.8	9,940	128
95	52.5	9,110	124
100	50.0	8,380	120
105	47.5	7,720	116
110	44.8	7,130	111
115	42.1	6,590	106
120	39.1	6,100	100
125	36.0	5,650	94
130	32.6	5,240	86
135	28.9	4,860	78
140	24.6	4,510	68
145	19.5	4,190	56
150	12.7	3,900	38

160' (48.8 m) Boom length			
Radius (Feet)	Boom Angle (Degrees)	Side Frames Extended (Pounds)	From Boom Pt. to Ground (Feet)
29	80.9	39,530 *	163
30	80.5	39,370 *	163
35	78.7	37,830	162
40	76.9	31,410	161
45	75.0	26,650	160
50	73.2	22,990	159
55	71.3	20,310	157
60	69.4	17,950	155
65	67.4	16,000	153
70	65.5	14,350	151
75	63.5	12,950	149
80	61.5	11,730	146
85	59.4	10,680	143
90	57.3	9,750	140
95	55.2	8,920	137
100	53.0	8,190	133
105	50.7	7,530	129
110	48.3	6,930	125
115	45.9	6,390	120
120	43.3	5,900	115
125	40.7	5,450	110
130	37.8	5,040	104
135	34.8	4,660	97
140	31.5	4,310	89
145	27.9	3,990	80
150	23.8	3,690	70
155	18.9	3,420	57
160	12.3	3,160	39

NOTES TO LIFTING CAPACITY

⚠ Warning

This rating chart is invalid if the crane has been modified or altered by use of other than GENUINE AMERICAN PARTS as such modifications or alterations may affect its capacity or safe operation. See American Crane Corporation Service Bulliten #259.

Ratings in this chart are in POUNDS and do not exceed the percentage of tipping specified for this crane by ANSI B30.5. All ratings require that the crane be standing level on a firm uniformly supporting surface.

Do not lift loads in excess of those shown on this chart. Lifting loads in excess of those shown or operation not in accordance with good operating practice, including limitations shown on page 3499 of Operator's Manual, can cause tipping, structural damage or catastrophic failure.

Asterisk (*) areas on this chart indicate ratings which are limited by strength of material or factors other than stability (tipping).

„RADIUS IN FEET“ is the horizontal distance at ground level from the crane centerline of rotation to a vertical line through the center of gravity of the suspended load.

When using the main boom fall with jib in place, the main fall ratings must be reduced by the jib effective weight shown on the jib rating chart plus twice the weight of all suspended blocks, slings, rope, etc., at the jib fall. See Appendix A.

When using the main boom fall with boom tip extension in place, the main fall ratings must be reduced by the weight of the boom tip extension plus twice the weight of all suspended blocks, slings, rope, etc., at the boom tip extension fall. See Appendix A.

Blocks, slings, buckets and other load carrying devices are considered part of the load. The weight of standard hoisting ropes for the rating at a given radius has been calculated as part of the boom point load and need not be considered in determining net allowable loads. See Appendix A.

This chart was developed exclusively for use with a boom only. Under no circumstances are these ratings to be interpreted for use with a jib.

Ratings shown on this chart make no allowance for such factors as out of plumb loads, wind, poor soil conditions, improper inflation of rubber tires and dynamic effects due to excessive operating speeds. The user (operator) must exercise judgement to make allowance for these conditions. See page 3499 of Operator's Manual for detailed information.

No account is taken of the wind force on the load. This effect, which can be substantial for loads with large surface areas, must be considered by the user. In any wind it is strongly recommended that taglines be used to control the load.

BOOM HOIST LINE – 14 parts of 5/8 inch diameter EIPS wire rope with a minimum breaking strength of 41,200 pounds.

PENDANT SUSPENSION LINE – 2 parts of 1-1/4 inch diameter MONOLAY wire rope with a minimum breaking strength of 172,800 pounds.

MAIN LOAD LINE – 7/8 inch diameter EIPS wire rope with a minimum breaking strength of 79,600 pounds.

ERECTION

Erection is with the A-Frame fully raised. Erection „OVER THE END“ is with the boom over the idler end. Erection „OVER-THE-SIDE“ is with the boom 90° to the sideframes and with the side frames extended. Blocks, slings and other load carrying devices must be on the ground during erection.

MAXIMUM BOOM & JIB SELF-ERECTION DATA - 46HI BOOM		
JIB	OVER-THE-END & OVER-THE-SIDE	
	BOOM LENGTH (FEET)	JIB LENGTH (FEET)
#9	160	50

BOOM LENGTH (FEET)	BOOM SECTIONS					
	20' 46HI INNER	5' 46HR CENTER	10' 46HR CENTER	20' 46HR CENTER	40' 46HR CENTER	20' 46HR or 46HI OUTER
	40	1	0	0	0	0
45	1	1	0	0	0	1
50	1	0	1	0	0	1
55	1	1	1	0	0	1
60	1	0	0	1	0	1
65	1	1	0	1	0	1
70	1	0	1	1	0	1
75	1	1	1	1	0	1
80	1	0	0	0	1	1
85	1	1	0	0	1	1
90	1	0	1	0	1	1
95	1	1	1	0	1	1
100	1	0	0	1	1	1
105	1	1	0	1	1	1
110	1	0	1	1	1	1
115	1	1	1	1	1	1
120	1	0	0	0	2	1
125	1	1	0	0	2	1
130	1	0	1	0	2	1
135	1	1	1	0	2	1
140	1	0	0	1	2	1
145	1	1	0	1	2	1
150	1	0	1	1	2	1
155	1	1	1	1	2	1
160	1	0	0	0	3	1

LOAD HOISTING INFORMATION - 7/8 inch diameter EIPS wire rope			
MAXIMUM LIFTING CAPACITY - LBS.	MINIMUM PARTS OF LINE	MAXIMUM HOISTING DISTANCE - FEET	
		MAIN - (RIGHT)	AUX. - (LEFT)
160,000	8	73	73
159,180	7	84	84
136,440	6	98	98
113,700	5	117	117
90,960	4	147	147
68,220	3	196	196
45,480	2	294	294
22,740	1	588	588

RANGE DIAGRAM, 47HI BOOM, #9HL JIB

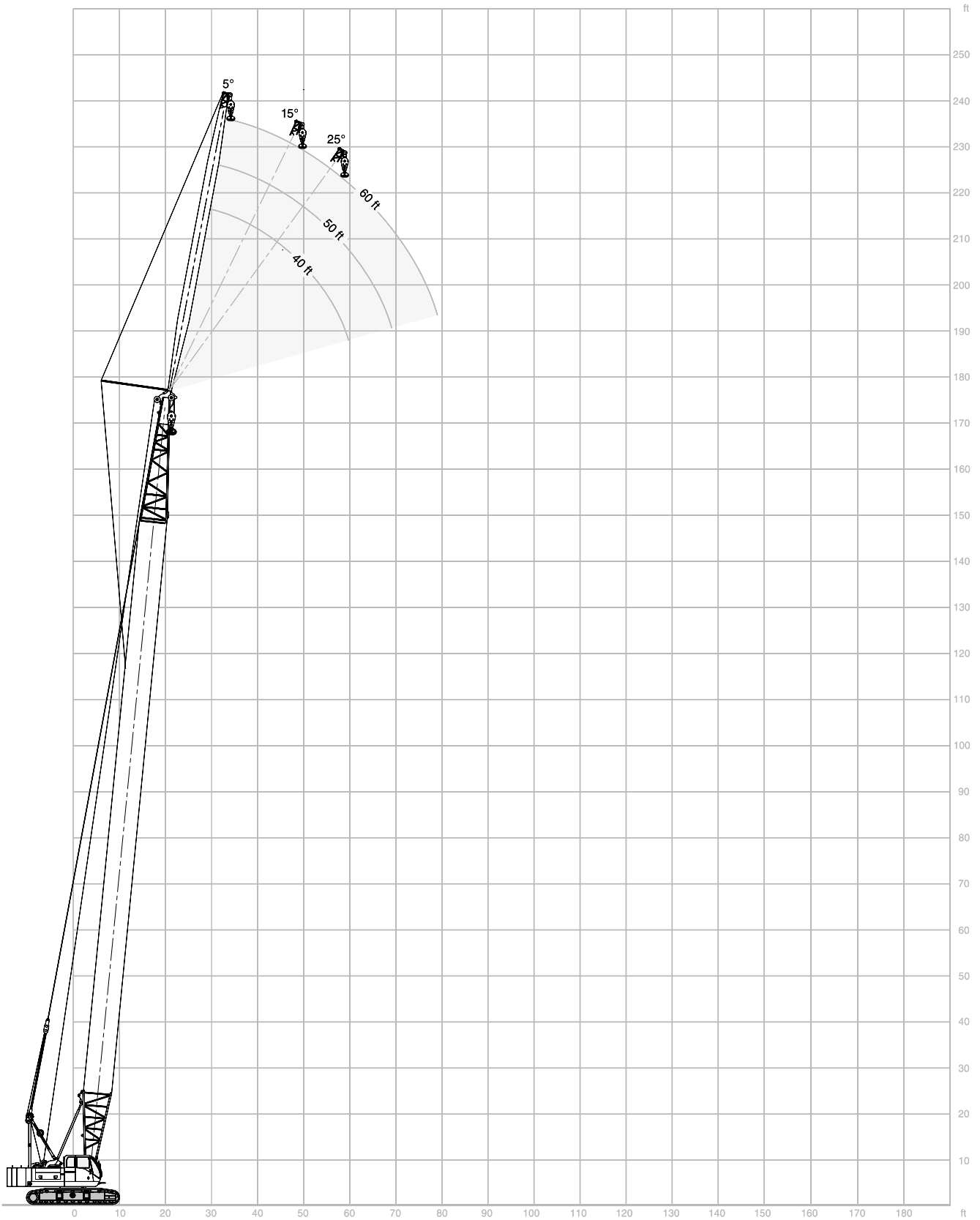

WITH 47HI BOOM, #9HL JIB

58,100 lb

360°

ANSI B 30.5

40' (12.2 m) Jib length

Boom length	Jib Radius (Feet)	5.0 Deg offset		15.0 Deg offset		25.0 Deg offset	
		Boom Angle	Rating (Pounds)	Boom Angle	Rating (Pounds)	Boom Angle	Rating (Pounds)
	30	80.7	22,550*	-	-	-	-
	35	78.6	22,550*	-	-	-	-
	40	76.5	22,190*	79.2	20,980*	-	-
	50	72.2	21,500*	74.9	20,440*	77.5	19,540*
100' (30.5 m)	60	67.9	19,650	70.5	19,650	73.0	19,100*
	70	63.4	16,060	66.0	16,070	68.4	16,070
	80	58.7	13,460	61.2	13,460	63.6	13,470
	90	53.7	11,490	56.2	11,490	58.4	11,500
	100	48.4	9,950	50.8	9,950	52.9	9,950

	31	80.9	22,530*	-	-	-	-
	35	79.3	22,530*	-	-	-	-
	40	77.4	22,390*	79.9	21,090*	-	-
	50	73.5	21,670*	76.0	20,540*	78.3	19,630*
110' (33.5 m)	60	69.4	19,440	71.9	19,440	74.2	19,190*
	70	65.3	15,860	67.7	15,860	70.0	15,860
	80	61.0	13,270	63.4	13,270	65.6	13,270
	90	56.5	11,290	58.9	11,290	61.0	11,290
	100	51.7	9,740	54.1	9,740	56.1	9,740
	110	46.6	8,490	48.9	8,490	50.8	8,490

	33	80.7	22,520*	-	-	-	-
	35	80.0	22,520*	-	-	-	-
	40	78.2	22,500*	80.6	21,150*	-	-
	50	74.5	21,850*	76.9	20,630*	79.1	19,480*
120' (36.6 m)	60	70.8	19,240	73.1	19,240	75.3	19,240
	70	66.9	15,660	69.2	15,660	71.4	15,670
	80	62.9	13,060	65.2	13,060	67.3	13,060
	90	58.8	11,080	61.1	11,080	63.1	11,080
	100	54.5	9,530	56.7	9,530	58.7	9,530
	110	49.9	8,280	52.1	8,280	53.9	8,280
	120	45.0	7,250	47.1	7,260	48.8	7,260

	34	80.9	22,500*	-	-	-	-
	35	80.6	22,500*	-	-	-	-
	40	78.9	22,500*	-	-	-	-
	50	75.4	22,020*	77.7	20,170*	79.8	16,440*
130' (39.6 m)	60	71.9	19,060	74.1	19,060	76.2	16,240*
	70	68.3	15,480	70.5	15,480	72.5	15,480
	80	64.7	12,870	66.8	12,880	68.8	12,880
	90	60.9	10,900	63.0	10,900	64.9	10,910
	100	56.9	9,350	59.0	9,350	60.8	9,360
	110	52.7	8,100	54.8	8,100	56.6	8,110
	120	48.3	7,070	50.4	7,080	52.0	7,080
	130	43.6	6,220	45.5	6,220	47.1	6,220

Boom length	Jib Radius (Feet)	5.0 Deg offset		15.0 Deg offset		25.0 Deg offset	
		Boom Angle	Rating (Pounds)	Boom Angle	Rating (Pounds)	Boom Angle	Rating (Pounds)
	36	80.8	20,590*	-	-	-	-
	40	79.5	20,210*	-	-	-	-
	50	76.3	19,260*	78.4	17,060*	80.4	13,890*
	60	73.0	18,250*	75.1	16,430*	77.0	13,600*
140' (42.7 m)	70	69.6	15,280	71.7	15,280	73.6	13,240*
	80	66.2	12,680	68.2	12,680	70.1	12,680
	90	62.6	10,700	64.7	10,700	66.5	10,700
	100	59.0	9,140	61.0	9,150	62.7	9,150
	110	55.1	7,890	57.1	7,900	58.8	7,900
	120	51.1	6,860	53.1	6,870	54.7	6,870
	130	46.9	6,010	48.8	6,010	50.3	6,010
	140	42.3	5,280	44.1	5,280	45.5	5,290

	37	81.0	17,400*	-	-	-	-
	40	80.1	17,190*	-	-	-	-
	50	77.0	16,300*	79.0	14,440*	80.9	11,750*
	60	73.9	15,370*	75.9	13,860*	77.7	11,470*
	70	70.7	14,480*	72.7	13,220*	74.5	11,070*
	80	67.5	12,480	69.4	12,480	71.2	10,580*
150' (45.7 m)	90	64.2	10,500	66.1	10,500	67.8	10,060*
	100	60.8	8,950	62.7	8,950	64.4	8,950
	110	57.2	7,700	59.1	7,700	60.7	7,700
	120	53.5	6,670	55.4	6,670	57.0	6,670
	130	49.7	5,810	51.5	5,810	53.0	5,810
	140	45.5	5,080	47.3	5,080	48.7	5,090
	150	41.1	4,460	42.8	4,460	44.1	4,460

	39	80.9	14,750*	-	-	-	-
	40	80.6	14,670*	-	-	-	-
	50	77.7	13,800*	79.6	12,290*	-	-
	60	74.7	12,930*	76.6	11,740*	78.4	9,670*
	70	71.7	12,130*	73.6	11,100*	75.3	9,260*
	80	68.7	11,330*	70.5	10,480*	72.2	8,800*
160' (48.8 m)	90	65.6	10,310	67.4	9,820*	69.1	8,290*
	100	62.4	8,760	64.2	8,760	65.8	7,810*
	110	59.1	7,510	60.9	7,510	62.4	7,320*
	120	55.6	6,480	57.4	6,480	58.9	6,480
	130	52.1	5,620	53.8	5,620	55.3	5,620
	140	48.3	4,890	50.0	4,890	51.4	4,900
	150	44.3	4,270	46.0	4,270	47.3	4,270
	160	40.0	3,720	41.6	3,720	42.8	3,730

WITH 47HI BOOM, #9HL JIB

58,100 lb

360°

ANSI B 30.5

50' (15.2 m) Jib length

Boom length	Jib Radius (Feet)	5.0 Deg offset		15.0 Deg offset		25.0 Deg offset	
		Boom Angle	Rating (Pounds)	Boom Angle	Rating (Pounds)	Boom Angle	Rating (Pounds)
	37	80.8	21,570*	-	-	-	-
	40	79.8	21,570*	-	-	-	-
	50	76.5	21,210*	79.2	18,370*	-	-
	60	73.2	19,110	75.9	17,960*	78.3	14,430*
130' (39.6 m)	70	69.9	15,520	72.5	15,520	74.9	14,230*
	80	66.4	12,920	69.0	12,920	71.4	12,920
	90	62.9	10,940	65.5	10,940	67.8	10,940
	100	59.2	9,380	61.8	9,390	64.0	9,390
	110	55.4	8,130	57.9	8,140	60.1	8,140
	120	51.4	7,100	53.8	7,110	55.9	7,110
	130	47.1	6,250	49.5	6,250	51.5	6,250

	38	80.9	19,020*	-	-	-	-
	40	80.3	19,010*	-	-	-	-
	50	77.3	18,100*	79.8	15,590*	-	-
	60	74.2	17,210*	76.6	15,150*	79.0	12,140*
140' (42.7 m)	70	71.0	15,330	73.5	14,540*	75.8	11,930*
	80	67.8	12,720	70.2	12,720	72.5	11,570*
	90	64.4	10,740	66.9	10,740	69.1	10,740
	100	61.0	9,190	63.4	9,190	65.6	9,190
	110	57.5	7,940	59.9	7,940	62.0	7,940
	120	53.8	6,910	56.1	6,910	58.2	6,910
	130	49.9	6,050	52.2	6,050	54.2	6,050
	140	45.8	5,310	48.0	5,310	49.9	5,320

	40	80.8	16,220*	-	-	-	-
	50	77.9	15,410*	80.3	13,300*	-	-
	60	75.0	14,500*	77.3	12,800*	79.6	10,310*
	70	72.0	13,690*	74.3	12,280*	76.5	10,040*
150' (45.7 m)	80	68.9	12,520	71.3	11,690*	73.4	9,660*
	90	65.8	10,530	68.1	10,540	70.2	9,270*
	100	62.6	8,980	64.9	8,980	67.0	8,810*
	110	59.3	7,730	61.6	7,730	63.6	7,730
	120	55.9	6,700	58.1	6,700	60.1	6,700
	130	52.3	5,840	54.5	5,840	56.4	5,850
	140	48.5	5,110	50.7	5,110	52.5	5,120
	150	44.5	4,490	46.7	4,490	48.4	4,490

Boom length	Jib Radius (Feet)	5.0 Deg offset		15.0 Deg offset		25.0 Deg offset	
		Boom Angle	Rating (Pounds)	Boom Angle	Rating (Pounds)	Boom Angle	Rating (Pounds)
	41	81.0	13,810*	-	-	-	-
	50	78.5	13,090*	80.8	11,330*	-	-
	60	75.7	12,280*	78.0	10,860*	80.1	8,710*
	70	72.9	11,490*	75.1	10,330*	77.2	8,420*
	80	70.0	10,770*	72.2	9,800*	74.3	8,050*
	90	67.0	10,080*	69.2	9,220*	71.3	7,660*
160' (48.8 m)	100	64.0	8,790	66.2	8,680*	68.2	7,240*
	110	60.9	7,540	63.1	7,540	65.0	6,830*
	120	57.7	6,510	59.9	6,510	61.8	6,410*
	130	54.4	5,650	56.5	5,650	58.4	5,660
	140	50.9	4,920	53.0	4,920	54.8	4,930
	150	47.3	4,300	49.3	4,300	51.0	4,300
	160	43.4	3,760	45.4	3,760	47.0	3,770

	43	80.9	11,660*	-	-	-	-
	50	79.0	11,130*	-	-	-	-
	60	76.4	10,340*	78.5	9,190*	80.6	7,380*
	70	73.7	9,620*	75.8	8,650*	77.8	7,040*
	80	70.9	8,940*	73.1	8,150*	75.0	6,670*
	90	68.1	8,300*	70.3	7,600*	72.2	6,290*
170' (51.8 m)	100	65.3	7,710*	67.4	7,120*	69.3	5,870*
	110	62.4	7,120*	64.4	6,600*	66.3	5,480*
	120	59.4	6,310	61.4	6,150*	63.2	5,090*
	130	56.3	5,450	58.3	5,460	60.1	4,690*
	140	53.0	4,720	55.1	4,730	56.8	4,310*
	150	49.7	4,100	51.6	4,100	53.3	3,920*
	160	46.1	3,550	48.1	3,550	49.6	3,540*
	170	42.3	3,070	44.2	3,080	45.7	3,080

WITH 47HI BOOM, #9HL JIB

58,100 lb

360°

ANSI B 30.5

60' (18.3 m) Jib length

Boom length	Jib Radius (Feet)	5.0 Deg offset		15.0 Deg offset		25.0 Deg offset	
		Boom Angle	Rating (Pounds)	Boom Angle	Rating (Pounds)	Boom Angle	Rating (Pounds)
	42	80.9	15,150*	-	-	-	-
	50	78.7	14,500*	-	-	-	-
	60	75.9	13,720*	78.7	11,780*	-	-
	70	73.1	12,920*	75.8	11,350*	78.3	8,990*
150' (45.7 m)	80	70.2	12,170*	72.9	10,860*	75.4	8,750*
	90	67.3	10,580	69.9	10,340*	72.4	8,460*
	100	64.3	9,010	66.9	9,020	69.3	8,120*
	110	61.2	7,760	63.8	7,760	66.1	7,740*
	120	58.0	6,730	60.6	6,730	62.9	6,740
	130	54.6	5,870	57.2	5,870	59.4	5,880
	140	51.2	5,140	53.7	5,150	55.9	5,150
	150	47.5	4,520	50.0	4,520	52.1	4,520

	44	80.8	12,820*	-	-	-	-
	50	79.3	12,400*	-	-	-	-
	60	76.6	11,610*	79.2	10,040*	-	-
	70	73.9	10,890*	76.5	9,560*	78.9	7,600*
	80	71.1	10,220*	73.7	9,090*	76.1	7,340*
	90	68.4	9,570*	70.9	8,630*	73.3	7,020*
160' (48.8 m)	100	65.5	8,830	68.0	8,130*	70.4	6,680*
	110	62.6	7,580	65.1	7,580	67.4	6,310*
	120	59.6	6,540	62.1	6,550	64.3	5,960*
	130	56.5	5,680	58.9	5,690	61.1	5,600*
	140	53.3	4,950	55.7	4,960	57.8	4,960
	150	49.9	4,330	52.3	4,330	54.3	4,330
	160	46.3	3,790	48.7	3,790	50.6	3,800

Boom length	Jib Radius (Feet)	5.0 Deg offset		15.0 Deg offset		25.0 Deg offset	
		Boom Angle	Rating (Pounds)	Boom Angle	Rating (Pounds)	Boom Angle	Rating (Pounds)
	45	81.0	10,920*	-	-	-	-
	50	79.7	10,520*	-	-	-	-
	60	77.2	9,830*	79.7	8,510*	-	-
	70	74.6	9,130*	77.1	8,060*	79.4	6,380*
	80	72.0	8,500*	74.5	7,580*	76.8	6,110*
	90	69.4	7,880*	71.8	7,140*	74.1	5,780*
170' (51.8 m)	100	66.6	7,300*	69.1	6,660*	71.3	5,440*
	110	63.9	6,780*	66.3	6,210*	68.5	5,090*
	120	61.1	6,270*	63.4	5,780*	65.6	4,740*
	130	58.1	5,490	60.5	5,370*	62.6	4,390*
	140	55.1	4,750	57.5	4,700	59.5	4,060*
	150	52.0	4,130	54.3	4,130	56.3	3,710*
	160	48.7	3,580	51.0	3,580	52.9	3,380*
	170	45.2	3,100	47.5	3,110	49.3	3,040*



NOTES TO LIFTING CAPACITY

⚠ Warning

This rating chart is invalid if the crane has been modified or altered by use of other than GENUINE AMERICAN PARTS as such modifications or alterations may affect its capacity or safe operation. See American Crane Corporation Service Bulliten #259.

Ratings in this chart are in POUNDS and do not exceed the percentage of tipping specified for this crane by ANSI B30.5. All ratings require that the crane be standing level on a firm uniformly supporting surface.

Do not lift loads in excess of those shown on this chart. Lifting loads in excess of those shown or operation not in accordance with good operating practice, including limitations shown on page 3499 of Operator's Manual, can cause tipping, structural damage or catastrophic failure.

Asterisk (*) areas on this chart indicate ratings which are limited by strength of material or factors other than stability (tipping).

„RADIUS IN FEET“ is the horizontal distance at ground level from the crane centerline of rotation to a vertical line through the center of gravity of the suspended load.

When using the main boom fall with jib in place, the main fall ratings must be reduced by the jib effective weight shown on the jib rating chart plus twice the weight of all suspended blocks, slings, rope, etc., at the jib fall. See Appendix A.

Blocks, slings, buckets and other load carrying devices are considered part of the load. The weight of standard hoisting ropes for the rating at a given radius has been calculated as part of the boom point load and need not be considered in determining net allowable loads. See Appendix A.

Ratings shown on this chart make no allowance for such factors as out of plumb loads, wind, poor soil conditions, improper inflation of rubber tires and dynamic effects due to excessive operating speeds. The user (operator) must exercise judgement to make allowance for these conditions. See page 3499 of Operator's Manual for detailed information.

No account is taken of the wind force on the load. This effect, which can be substantial for loads with large surface areas, must be considered by the user. In any wind it is strongly recommended that taglines be used to control the load.

BOOM HOIST LINE is 14 parts of 5/8 inch diameter EIPS wire rope with a minimum breaking strength of 41,200 pounds.

PENDANT SUSPENSION LINE is 2 parts of 1-1/4 inch diameter MONOLAY wire rope with a minimum breaking strength of 172,800 pounds.

WHIP LINE is 7/8 inch diameter EIPS wire rope with a minimum breaking strength of 79,600 pounds.

ERECTION

Erection is with the A-Frame fully raised. Erection „OVER THE END“ is with the boom over the idler end. Erection „OVER THE SIDE“ is with the boom 90° to the sideframes and with the side frames extended. Blocks, slings and other load carrying devices must be on the ground during erection.

MAXIMUM BOOM & JIB SELF-ERECTION DATA		
OVER THE END & OVER THE SIDE		
	BOOM LENGTH (FEET)	JIB LENGTH (FEET)
#9HL JIB	200	0
	170	60

47HI BOOM COMPOSITION CHART					
BOOM LENGTH (FEET)	BOOM SECTIONS				
	20' 47HI INNER	10' 47H CENTER	20' 47H CENTER	30' 47H CENTER	20' 47H or 47HI OUTER
40	1	0	0	0	1
50	1	1	0	0	1
60	1	0	1	0	1
70	1	0	0	1	1
80	1	1	0	1	1
90	1	0	1	1	1
100	1	0	0	2	1
110	1	1	0	2	1
120	1	0	1	2	1
130	1	0	0	3	1
140	1	1	0	3	1
150	1	0	1	3	1
160	1	0	0	4	1
170	1	1	0	4	1

LOAD HOISTING INFORMATION - 7/8" EIPS ROPE			
MAXIMUM LIFTING CAPACITY - LBS.	MINIMUM PARTS OF LINE	MAXIMUM HOISTING DISTANCE - FEET	
		MAIN - (RIGHT)	AUX. - (LEFT)
22,550	1	588	588

#9HL JIB COMPOSITION CHART								
JIB LENGTH (FEET)	20' INNER	10' CENTER	20' CENTER	20' OUTER	EFF. JIB WEIGHT (POUNDS)	JIB OFFSET "A" IN FEET		
						5°	15°	25°
40	1	0	0	1	1,850	4.75'	9.75'	14.66'
50	1	1	0	1	2,350	5.50'	11.66'	17.83'
60	1	0	1	1	2,750	6.08'	13.50'	20.75'

Note: The #9HL jib mounted on a 47HI outer requires the use of a 47HI / #9HL jib adaptor. Refer to the HC 80 Operators Manual for additional information.

RANGE DIAGRAM, 46HI BOOM, #9 ANGLE JIB

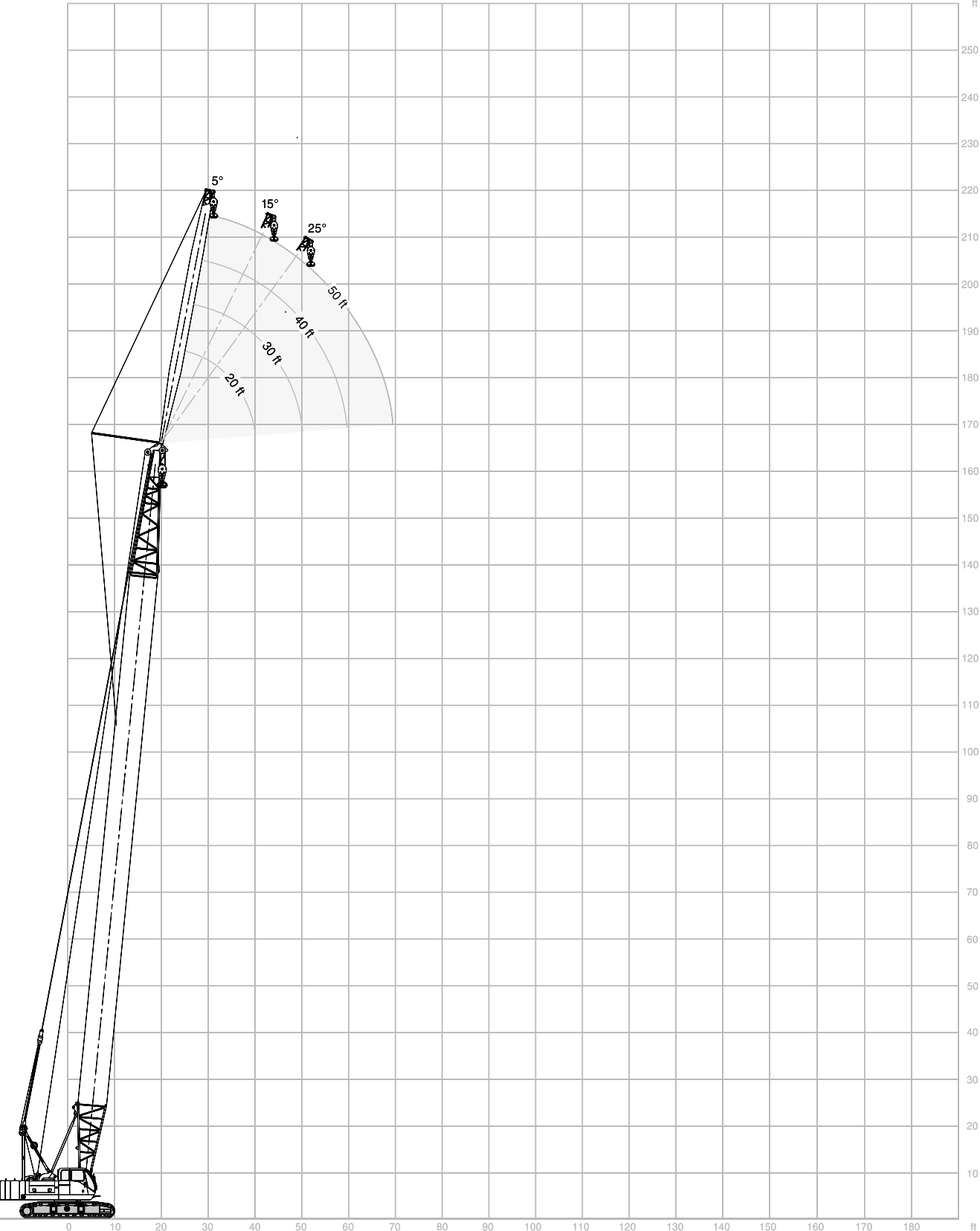

WITH 46HI BOOM, #9 ANGLE JIB

58,100 lb

360°

ANSI B 30.5

20' (6.1 m) Jib length

Boom length	Jib Radius (Feet)	5.0 Deg offset		15.0 Deg offset		25.0 Deg offset	
		Boom Angle	Rating (Pounds)	Boom Angle	Rating (Pounds)	Boom Angle	Rating (Pounds)
50' (15.2 m)	17	80.7	18,250*	-	-	-	-
	20	78.2	18,250*	80.9	18,250*	-	-
	25	74.1	18,250*	76.7	18,250*	79.2	18,250*
	30	69.8	18,250*	72.5	18,250*	74.9	18,250*
	35	65.5	18,250*	68.1	18,250*	70.5	18,250*
	40	60.9	18,250*	63.5	18,250*	65.8	18,250*
	50	51.1	18,250*	53.6	18,250*	55.7	18,250*

60' (18.3 m)	19	80.4	18,250*	-	-	-	-
	20	79.7	18,250*	-	-	-	-
	25	76.1	18,250*	78.4	18,250*	80.6	18,250*
	30	72.4	18,250*	74.7	18,250*	76.9	18,250*
	35	68.7	18,250*	71.0	18,250*	73.1	18,250*
	40	64.8	18,250*	67.1	18,250*	69.1	18,250*
	50	56.7	18,250*	58.9	18,250*	60.8	18,250*
	60	47.6	18,250*	49.7	18,250*	51.5	18,250*

70' (21.3 m)	20	80.8	18,250*	-	-	-	-
	25	77.6	18,250*	79.7	18,250*	-	-
	30	74.4	18,250*	76.5	18,250*	78.4	18,250*
	35	71.1	18,250*	73.2	18,250*	75.1	18,250*
	40	67.7	18,250*	69.8	18,250*	71.6	18,250*
	50	60.7	18,250*	62.7	18,250*	64.5	18,250*
	60	53.2	18,250*	55.1	18,250*	56.8	18,250*
	70	44.7	16,020	46.6	16,020	48.1	16,020

80' (24.4 m)	22	80.6	18,250*	-	-	-	-
	25	78.9	18,250*	80.8	18,250*	-	-
	30	76.0	18,250*	77.8	18,250*	79.6	18,250*
	35	73.0	18,250*	74.9	18,250*	76.6	18,250*
	40	70.0	18,250*	71.9	18,250*	73.6	18,000*
	50	63.9	18,250*	65.7	18,250*	67.3	18,250*
	60	57.3	18,250*	59.1	18,250*	60.6	18,250*
	70	50.3	15,820	52.0	15,820	53.4	15,820
	80	42.3	13,220	44.0	13,220	45.2	13,220

90' (27.4 m)	23	80.9	18,250*	-	-	-	-
	25	79.9	18,250*	-	-	-	-
	30	77.2	18,250*	79.0	18,250*	80.6	18,250*
	35	74.6	18,250*	76.3	18,250*	77.9	18,250*
	40	71.9	18,250*	73.6	18,250*	75.1	18,250*
	50	66.4	18,250*	68.0	18,250*	69.5	18,250*
	60	60.6	18,250*	62.2	18,250*	63.6	18,250*
	70	54.5	15,570	56.0	15,570	57.4	15,580
	80	47.8	12,980	49.3	12,980	50.6	12,980
	90	40.3	11,000	41.7	11,000	42.8	11,000

100' (30.5 m)	25	80.7	18,250*	-	-	-	-
	30	78.3	18,250*	79.9	18,250*	-	-
	35	75.9	18,250*	77.5	18,250*	78.9	18,250*
	40	73.4	18,250*	75.0	18,250*	76.4	18,250*
	50	68.4	18,250*	70.0	18,250*	71.3	18,250*
	60	63.2	18,250*	64.7	18,250*	66.1	18,250*
	70	57.8	15,350	59.3	15,350	60.5	15,350
	80	52.0	12,740	53.4	12,740	54.6	12,740
	90	45.6	10,760	47.0	10,760	48.1	10,760
	100	38.5	9,220	39.8	9,220	40.7	9,220

110' (33.5 m)	26	81.0	18,250*	-	-	-	-
	30	79.2	18,250*	80.7	18,250*	-	-
	35	77.0	18,250*	78.4	18,250*	79.8	18,250*
	40	74.7	18,250*	76.2	18,250*	77.5	18,250*
	50	70.2	18,250*	71.6	18,250*	72.9	18,250*
	60	65.4	18,250*	66.8	18,250*	68.1	18,250*
	70	60.5	15,100	61.9	15,100	63.1	15,100
	80	55.3	12,500	56.7	12,500	57.8	12,500
	90	49.8	10,520	51.1	10,520	52.2	10,520
	100	43.7	8,960	45.0	8,970	46.0	8,970
	110	36.9	7,720	38.1	7,720	38.9	7,720

120' (36.6 m)	28	80.8	18,250*	-	-	-	-
	30	80.0	18,250*	-	-	-	-
	35	77.9	18,250*	79.3	18,250*	80.5	18,250*
	40	75.8	18,250*	77.2	18,250*	78.4	18,250*
	50	71.6	18,250*	72.9	18,250*	74.1	18,250*
	60	67.3	18,250*	68.6	18,250*	69.7	18,250*
	70	62.8	14,890	64.1	14,890	65.2	14,900
	80	58.1	12,290	59.4	12,290	60.4	12,290
	90	53.2	10,310	54.4	10,310	55.4	10,310
	100	47.9	8,750	49.1	8,750	50.0	8,760
	110	42.1	7,510	43.2	7,510	44.1	7,510
	120	35.5	6,490	36.6	6,490	37.3	6,490

130' (39.6 m)	30	80.7	18,250*	-	-	-	-
	35	78.7	18,250*	80.0	18,250*	-	-
	40	76.8	18,250*	78.0	18,250*	79.2	18,250*
	50	72.9	18,250*	74.1	18,250*	75.2	18,250*
	60	68.9	18,250*	70.1	18,250*	71.2	18,250*
	70	64.7	14,660	65.9	14,660	67.0	14,660
	80	60.4	12,060	61.6	12,060	62.7	12,060
	90	56.0	10,070	57.1	10,080	58.1	10,080
	100	51.2	8,520	52.4	8,520	53.3	8,520
	110	46.1	7,270	47.3	7,270	48.1	7,270
	120	40.6	6,230	41.6	6,230	42.4	6,240
	130	34.3	5,380	35.3	5,380	35.9	5,390

140' (42.7 m)	31	80.9	18,250*	-	-	-	-
	35	79.4	18,250*	80.6	18,250*	-	-
	40	77.6	18,250*	78.8	18,250*	79.9	18,250*
	50	74.0	18,250*	75.1	18,250*	76.2	18,250*
	60	70.2	18,030	71.4	18,030	72.4	18,030
	70	66.4	14,430	67.5	14,430	68.5	14,430
	80	62.4	11,820	63.6	11,820	64.5	11,820
	90	58.3	9,840	59.4	9,840	60.4	9,840
	100	54.0	8,290	55.1	8,290	56.0	8,290
	110	49.5	7,030	50.6	7,030	51.4	7,030
	120	44.6	6,000	45.6	6,000	46.4	6,010
	130	39.2	5,150	40.2	5,150	40.9	5,150
	140	33.1	4,420	34.1	4,420	34.6	4,420

WITH 46HI BOOM, #9 ANGLE JIB

58,100 lb **360°** **ANSI B 30.5**

20' (6.1 m) Jib length

Boom length	Jib Radius (Feet)	5.0 Deg offset		15.0 Deg offset		25.0 Deg offset	
		Boom Angle	Rating (Pounds)	Boom Angle	Rating (Pounds)	Boom Angle	Rating (Pounds)
	33	80.7	18,250*	-	-	-	-
	35	80.1	18,250*	-	-	-	-
	40	78.4	18,250*	79.5	18,250*	80.5	18,250*
	50	74.9	18,250*	76.0	18,250*	77.0	18,250*
	60	71.4	17,790	72.5	17,790	73.5	17,790
	70	67.8	14,200	68.9	14,200	69.9	14,200
150' (45.7 m)	80	64.2	11,580	65.2	11,580	66.2	11,590
	90	60.4	9,600	61.4	9,600	62.3	9,600
	100	56.4	8,040	57.5	8,040	58.3	8,040
	110	52.3	6,790	53.3	6,790	54.1	6,790
	120	47.9	5,760	48.9	5,760	49.7	5,770
	130	43.2	4,900	44.2	4,900	44.9	4,900
	140	38.0	4,170	38.9	4,170	39.6	4,180
	150	32.1	3,550	33.0	3,560	33.5	3,560

Boom length	Jib Radius (Feet)	5.0 Deg offset		15.0 Deg offset		25.0 Deg offset	
		Boom Angle	Rating (Pounds)	Boom Angle	Rating (Pounds)	Boom Angle	Rating (Pounds)
	34	80.9	18,250*	-	-	-	-
	35	80.6	18,250*	-	-	-	-
	40	79.0	18,250*	80.1	18,250*	-	-
	50	75.8	18,250*	76.8	18,250*	77.8	16,580*
	60	72.5	17,580	73.5	17,580	74.5	15,770*
	70	69.1	13,990	70.2	13,990	71.1	13,990
160' (48.8 m)	80	65.7	11,380	66.7	11,380	67.6	11,380
	90	62.2	9,390	63.2	9,400	64.0	9,400
	100	58.5	7,830	59.5	7,830	60.3	7,840
	110	54.7	6,580	55.7	6,580	56.5	6,590
	120	50.7	5,540	51.7	5,540	52.4	5,550
	130	46.5	4,690	47.4	4,690	48.1	4,690
	140	41.9	3,950	42.8	3,950	43.5	3,950
	150	36.9	3,330	37.8	3,330	38.3	3,330
	160	31.2	2,790	32.0	2,790	32.4	2,790

30' (9.1 m) Jib length

Boom length	Jib Radius (Feet)	5.0 Deg offset		15.0 Deg offset		25.0 Deg offset	
		Boom Angle	Rating (Pounds)	Boom Angle	Rating (Pounds)	Boom Angle	Rating (Pounds)
	24	80.8	18,250*	-	-	-	-
	25	80.3	18,250*	-	-	-	-
	30	77.7	18,250*	80.3	18,250*	-	-
	35	75.0	18,250*	77.6	18,250*	80.0	18,250*
80' (24.4 m)	40	72.3	18,250*	74.9	18,250*	77.3	18,250*
	50	66.8	18,250*	69.3	18,250*	71.6	18,250*
	60	61.0	18,250*	63.5	18,250*	65.7	18,250*
	70	54.9	15,910	57.3	15,920	59.4	15,920
	80	48.2	13,320	50.6	13,320	52.5	13,320

Boom length	Jib Radius (Feet)	5.0 Deg offset		15.0 Deg offset		25.0 Deg offset	
		Boom Angle	Rating (Pounds)	Boom Angle	Rating (Pounds)	Boom Angle	Rating (Pounds)
	29	80.7	18,250*	-	-	-	-
	30	80.3	18,250*	-	-	-	-
	35	78.3	18,250*	80.3	18,250*	-	-
	40	76.2	18,250*	78.2	18,250*	80.1	18,250*
110' (33.5 m)	50	72.0	18,250*	74.0	18,250*	75.8	18,250*
	60	67.6	18,250*	69.6	18,250*	71.4	18,250*
	70	63.1	15,180	65.1	15,180	66.8	15,190
	80	58.4	12,570	60.4	12,570	62.0	12,580
	90	53.5	10,590	55.4	10,590	57.0	10,60
	100	48.2	9,040	50.0	9,050	51.5	9,050
	110	42.4	7,790	44.2	7,790	45.6	7,790

	26	80.6	18,250*	-	-	-	-
	30	78.7	18,250*	-	-	-	-
	35	76.3	18,250*	78.7	18,250*	80.9	18,250*
	40	73.8	18,250*	76.2	18,250*	78.4	18,250*
90' (27.4 m)	50	68.8	18,250*	71.2	18,250*	73.3	18,250*
	60	63.6	18,250*	65.9	18,250*	68.0	18,250*
	70	58.2	15,670	60.4	15,670	62.4	15,670
	80	52.4	13,060	54.6	13,060	56.4	13,060
	90	46.0	11,080	48.1	11,080	49.9	11,080

	30	81.0	18,250*	-	-	-	-
	35	79.1	18,250*	81.0	18,250*	-	-
	40	77.1	18,250*	79.0	18,250*	80.8	18,250*
	50	73.2	18,250*	75.1	18,250*	76.8	18,250*
120' (36.6 m)	60	69.2	18,250*	71.0	18,250*	72.7	18,250*
	70	65.0	14,970	66.9	14,970	68.5	14,970
	80	60.8	12,370	62.6	12,370	64.2	12,370
	90	56.3	10,380	58.1	10,390	59.6	10,390
	100	51.5	8,830	53.3	8,830	54.7	8,830
	110	46.5	7,580	48.2	7,580	49.5	7,580
	120	40.9	6,540	42.5	6,540	43.8	6,550

	27	80.9	18,250*	-	-	-	-
	30	79.6	18,250*	-	-	-	-
	35	77.4	18,250*	79.5	18,250*	-	-
	40	75.1	18,250*	77.3	18,250*	79.3	18,250*
100' (30.5 m)	50	70.5	18,250*	72.7	18,250*	74.7	18,250*
	60	65.8	18,250*	67.9	18,250*	69.8	18,250*
	70	60.9	15,430	63.0	15,430	64.8	15,430
	80	55.7	12,820	57.7	12,820	59.5	12,820
	90	50.2	10,840	52.2	10,840	53.8	10,840
	100	44.1	9,290	46.0	9,300	47.6	9,300

	32	80.8	18,250*	-	-	-	-
	35	79.7	18,250*	-	-	-	-
	40	77.9	18,250*	79.7	18,250*	-	-
	50	74.3	18,250*	76.0	18,250*	77.7	18,250*
130' (39.6 m)	60	70.5	18,250*	72.3	18,250*	73.9	18,250*
	70	66.7	14,730	68.4	14,730	70.0	14,740
	80	62.7	12,120	64.4	12,120	66.0	12,120
	90	58.6	10,140	60.3	10,140	61.8	10,140
	100	54.3	8,580	56.0	8,580	57.4	8,580
	110	49.8	7,330	51.4	7,330	52.7	7,330
	120	44.9	6,300	46.5	6,300	47.7	6,310
	130	39.5	5,440	41.0	5,440	42.2	5,440

WITH 46HI BOOM, #9 ANGLE JIB

58,100 lb 360° ANSI B 30.5

30' (9.1 m) Jib length

Boom length	Jib Radius (Feet)	5.0 Deg offset		15.0 Deg offset		25.0 Deg offset	
		Boom Angle	Rating (Pounds)	Boom Angle	Rating (Pounds)	Boom Angle	Rating (Pounds)
	34	80.7	18,250*	-	-	-	-
	35	80.3	18,250*	-	-	-	-
	40	78.6	18,250*	80.3	18,250*	-	-
	50	75.2	18,250*	76.9	18,250*	78.4	18,250*
	60	71.7	18,090	73.4	18,090	74.9	18,090
	70	68.1	14,500	69.8	14,500	71.2	14,500
140' (42.7 m)	80	64.5	11,880	66.1	11,880	67.5	11,890
	90	60.7	9,900	62.3	9,900	63.7	9,900
	100	56.7	8,350	58.3	8,350	59.6	8,350
	110	52.6	7,090	54.1	7,090	55.4	7,090
	120	48.2	6,060	49.7	6,060	50.9	6,070
	130	43.5	5,210	44.9	5,210	46.1	5,210
	140	38.3	4,470	39.7	4,480	40.7	4,480

Boom length	Jib Radius (Feet)	5.0 Deg offset		15.0 Deg offset		25.0 Deg offset	
		Boom Angle	Rating (Pounds)	Boom Angle	Rating (Pounds)	Boom Angle	Rating (Pounds)
	37	80.8	18,250*	-	-	-	-
	40	79.8	18,250*	-	-	-	-
	50	76.8	18,250*	78.3	17,840*	79.7	14,960*
	60	73.7	17,640	75.2	17,030*	76.5	14,430*
	70	70.5	14,050	72.0	14,050	73.3	13,770*
	80	67.3	11,430	68.8	11,430	70.1	11,440
160' (48.8 m)	90	64.0	9,450	65.4	9,450	66.7	9,450
	100	60.6	7,890	62.0	7,890	63.3	7,890
	110	57.1	6,640	58.5	6,640	59.7	6,640
	120	53.4	5,600	54.8	5,600	55.9	5,600
	130	49.5	4,740	50.9	4,740	52.0	4,740
	140	45.4	4,010	46.7	4,010	47.8	4,010
	150	41.0	3,380	42.3	3,380	43.2	3,380
	160	36.1	2,840	37.3	2,850	38.2	2,850

	35	80.9	18,250*	-	-	-	-
	40	79.3	18,250*	80.9	18,250*	-	-
	50	76.0	18,250*	77.6	18,250*	79.1	17,490*
	60	72.8	17,860	74.3	17,860	75.7	16,980*
	70	69.4	14,260	70.9	14,260	72.3	14,260
	80	66.0	11,650	67.5	11,650	68.9	11,650
150' (45.7 m)	90	62.4	9,660	63.9	9,670	65.3	9,670
	100	58.8	8,100	60.3	8,100	61.6	8,110
	110	55.0	6,850	56.5	6,850	57.7	6,860
	120	51.0	5,810	52.4	5,810	53.6	5,820
	130	46.8	4,960	48.2	4,960	49.3	4,960
	140	42.2	4,220	43.5	4,220	44.6	4,230
	150	37.2	3,600	38.5	3,600	39.4	3,600

40' (12.2 m) Jib length

Boom length	Jib Radius (Feet)	5.0 Deg offset		15.0 Deg offset		25.0 Deg offset	
		Boom Angle	Rating (Pounds)	Boom Angle	Rating (Pounds)	Boom Angle	Rating (Pounds)
	30	80.7	18,250*	-	-	-	-
	35	78.6	18,250*	-	-	-	-
	40	76.5	18,250*	79.3	18,250*	-	-
	50	72.3	18,250*	75.0	17,790*	77.5	16,310*
100' (30.5 m)	60	68.0	18,250*	70.6	16,840*	73.1	15,650*
	70	63.5	15,480	66.1	15,490	68.5	15,060*
	80	58.8	12,880	61.4	12,880	63.7	12,890
	90	53.9	10,900	56.4	10,900	58.6	10,910
	100	48.6	9,340	51.0	9,350	53.1	9,350

Boom length	Jib Radius (Feet)	5.0 Deg offset		15.0 Deg offset		25.0 Deg offset	
		Boom Angle	Rating (Pounds)	Boom Angle	Rating (Pounds)	Boom Angle	Rating (Pounds)
	33	80.8	18,250*	-	-	-	-
	35	80.1	18,250*	-	-	-	-
	40	78.2	18,250*	80.6	18,250*	-	-
	50	74.6	18,250*	76.9	18,220*	79.1	16,560*
120' (36.6 m)	60	70.8	18,250*	73.2	17,310*	75.3	15,890*
	70	67.0	15,020	69.3	15,020	71.4	15,030
	80	63.1	12,410	65.3	12,410	67.4	12,410
	90	58.9	10,430	61.2	10,430	63.2	10,430
	100	54.6	8,870	56.9	8,870	58.8	8,870
	110	50.1	7,620	52.3	7,620	54.1	7,620
	120	45.2	6,590	47.3	6,590	49.0	6,600

	31	80.9	18,250*	-	-	-	-
	35	79.4	18,250*	-	-	-	-
	40	77.4	18,250*	80.0	18,250*	-	-
	50	73.5	18,250*	76.0	17,950*	78.4	16,410*
110' (33.5 m)	60	69.5	18,250*	72.0	17,070*	74.3	15,760*
	70	65.4	15,240	67.8	15,240	70.1	15,200*
	80	61.1	12,630	63.5	12,630	65.7	12,630
	90	56.6	10,640	59.0	10,650	61.1	10,650
	100	51.9	9,090	54.2	9,090	56.2	9,090
	110	46.8	7,840	49.1	7,840	51.0	7,840

	34	81.0	18,250*	-	-	-	-
	35	80.6	18,250*	-	-	-	-
	40	78.9	18,250*	-	-	-	-
	50	75.5	18,250*	77.7	18,250*	79.8	16,640*
130' (39.6 m)	60	72.0	18,250*	74.2	17,560*	76.3	16,060*
	70	68.4	14,780	70.6	14,780	72.6	14,780
	80	64.8	12,160	66.9	12,160	68.9	12,170
	90	61.0	10,180	63.1	10,180	65.0	10,190
	100	57.0	8,630	59.1	8,630	61.0	8,630
	110	52.9	7,370	54.9	7,370	56.7	7,380
	120	48.5	6,340	50.5	6,340	52.2	6,350
	130	43.8	5,480	45.7	5,480	47.3	5,480

WITH 46HI BOOM, #9 ANGLE JIB

58,100 lb

360°

ANSI B 30.5

40' (12.2 m) Jib length

Boom length	Jib Radius (Feet)	5.0 Deg offset		15.0 Deg offset		25.0 Deg offset	
		Boom Angle	Rating (Pounds)	Boom Angle	Rating (Pounds)	Boom Angle	Rating (Pounds)
	36	80.8	18,250*	-	-	-	-
	40	79.6	18,250*	-	-	-	-
	50	76.3	18,250*	78.4	18,250*	80.4	16,720*
	60	73.0	18,140	75.1	17,770*	77.1	16,160*
140' (42.7 m)	70	69.7	14,540	71.7	14,540	73.6	14,550
	80	66.2	11,930	68.3	11,930	70.1	11,930
	90	62.7	9,940	64.7	9,950	66.5	9,950
	100	59.1	8,390	61.1	8,390	62.8	8,400
	110	55.3	7,130	57.2	7,130	58.9	7,140
	120	51.3	6,100	53.2	6,110	54.8	6,110
	130	47.0	5,250	48.9	5,250	50.5	5,250
	140	42.5	4,510	44.3	4,510	45.7	4,520

	38	80.7	18,250*	-	-	-	-
	40	80.1	18,250*	-	-	-	-
	50	77.0	18,250*	79.0	18,250*	80.9	15,440*
	60	73.9	17,900	75.9	17,900*	77.8	15,190*
	70	70.8	14,310	72.7	14,310	74.6	14,310
	80	67.6	11,690	69.5	11,690	71.3	11,700
150' (45.7 m)	90	64.3	9,710	66.2	9,710	67.9	9,710
	100	60.9	8,150	62.8	8,150	64.4	8,150
	110	57.3	6,890	59.2	6,890	60.8	6,890
	120	53.7	5,860	55.5	5,860	57.1	5,860
	130	49.8	5,000	51.6	5,000	53.1	5,000
	140	45.7	4,260	47.5	4,260	48.9	4,270
	150	41.3	3,640	43.0	3,640	44.3	3,640

50' (15.2 m) Jib length

Boom length	Jib Radius (Feet)	5.0 Deg offset		15.0 Deg offset		25.0 Deg offset	
		Boom Angle	Rating (Pounds)	Boom Angle	Rating (Pounds)	Boom Angle	Rating (Pounds)
	37	80.8	18,250*	-	-	-	-
	40	79.8	18,200*	-	-	-	-
	50	76.6	16,970*	79.2	14,740*	-	-
	60	73.3	15,830*	75.9	13,950*	78.4	12,580*
130' (39.6 m)	70	69.9	14,810	72.5	13,290*	75.0	12,040*
	80	66.5	12,200	69.1	12,200	71.5	11,630*
	90	63.0	10,210	65.5	10,220	67.8	10,220
	100	59.3	8,650	61.9	8,650	64.1	8,660
	110	55.5	7,400	58.0	7,400	60.2	7,410
	120	51.5	6,360	54.0	6,370	56.1	6,370
	130	47.3	5,510	49.7	5,510	51.7	5,510

	38	81.0	18,250*	-	-	-	-
	40	80.4	18,250*	-	-	-	-
	50	77.3	17,190*	79.8	14,830*	-	-
	60	74.2	16,110*	76.7	14,110*	79.0	12,630*
140' (42.7 m)	70	71.0	14,580	73.5	13,440*	75.8	12,150*
	80	67.8	11,960	70.3	11,960	72.5	11,760*
	90	64.5	9,980	66.9	9,980	69.1	9,980
	100	61.1	8,420	63.5	8,420	65.7	8,420
	110	57.6	7,170	60.0	7,170	62.0	7,170
	120	53.9	6,130	56.3	6,130	58.3	6,130
	130	50.1	5,270	52.3	5,270	54.3	5,270
	140	45.9	4,540	48.2	4,540	50.0	4,550

Boom length	Jib Radius (Feet)	5.0 Deg offset		15.0 Deg offset		25.0 Deg offset	
		Boom Angle	Rating (Pounds)	Boom Angle	Rating (Pounds)	Boom Angle	Rating (Pounds)
	39	80.9	18,250*	-	-	-	-
	40	80.6	18,250*	-	-	-	-
	50	77.7	18,250*	79.6	16,450*	-	-
	60	74.8	17,480*	76.6	15,780*	78.4	12,960*
	70	71.8	14,090	73.6	14,090	75.4	12,510*
	80	68.7	11,480	70.6	11,480	72.3	11,480
160' (48.8 m)	90	65.6	9,480	67.5	9,480	69.1	9,490
	100	62.4	7,930	64.3	7,930	65.9	7,930
	110	59.2	6,670	61.0	6,670	62.5	6,670
	120	55.7	5,640	57.5	5,640	59.0	5,640
	130	52.2	4,770	53.9	4,770	55.4	4,770
	140	48.4	4,040	50.2	4,040	51.6	4,050
	150	44.5	3,410	46.1	3,420	47.5	3,420
	160	40.2	2,870	41.8	2,870	43.0	2,880

Boom length	Jib Radius (Feet)	5.0 Deg offset		15.0 Deg offset		25.0 Deg offset	
		Boom Angle	Rating (Pounds)	Boom Angle	Rating (Pounds)	Boom Angle	Rating (Pounds)
	40	80.9	18,250*	-	-	-	-
	50	77.9	17,430*	80.3	14,980*	-	-
	60	75.0	16,350*	77.4	14,280*	79.6	12,730*
	70	72.0	14,330	74.4	13,580*	76.6	12,230*
150' (45.7 m)	80	69.0	11,720	71.3	11,720	73.5	11,720
	90	65.9	9,730	68.2	9,730	70.3	9,740
	100	62.7	8,170	65.0	8,170	67.0	8,180
	110	59.4	6,920	61.7	6,920	63.7	6,920
	120	56.0	5,880	58.2	5,880	60.2	5,880
	130	52.4	5,020	54.6	5,020	56.5	5,020
	140	48.7	4,290	50.8	4,290	52.7	4,300
	150	44.7	3,660	46.8	3,670	48.5	3,670

	42	80.7	18,250*	-	-	-	-
	50	78.5	17,480*	80.8	14,960*	-	-
	60	75.7	16,500*	78.0	14,360*	80.1	11,540*
	70	72.9	14,120	75.1	13,740*	77.2	11,230*
	80	70.0	11,500	72.3	11,500	74.3	10,820*
	90	67.1	9,510	69.3	9,510	71.3	9,510
160' (48.8 m)	100	64.1	7,950	66.3	7,960	68.3	7,960
	110	61.0	6,690	63.2	6,690	65.1	6,700
	120	57.8	5,660	60.0	5,660	61.8	5,670
	130	54.5	4,800	56.6	4,800	58.5	4,810
	140	51.1	4,060	53.1	4,060	54.9	4,070
	150	47.4	3,430	49.5	3,440	51.2	3,440
	160	43.5	2,890	45.5	2,890	47.1	2,900



NOTES TO LIFTING CAPACITY

Warning

This rating chart is invalid if the crane has been modified or altered by use of other than GENUINE AMERICAN PARTS as such modifications or alterations may affect its capacity or safe operation. See American Crane Corporation Service Bulletin #259.

Ratings in this chart are in POUNDS and do not exceed the percentage of tipping specified for this crane by ANSI B30.5. All ratings require that the crane be standing level on a firm uniformly supporting surface.

Do not lift loads in excess of those shown on this chart. Lifting loads in excess of those shown or operation not in accordance with good operating practice, including limitations shown on page 3499 of Operator's Manual, can cause tipping, structural damage or catastrophic failure.

Asterisk (*) areas on this chart indicate ratings which are limited by strength of material or factors other than stability (tipping).

„RADIUS IN FEET“ is the horizontal distance at ground level from the crane centerline of rotation to a vertical line through the center of gravity of the suspended load.

When using the main boom fall with jib in place, the main fall ratings must be reduced by the jib effective weight shown on the jib rating chart plus twice the weight of all suspended blocks, slings, rope, etc., at the jib fall. See Appendix A.

Blocks, slings, buckets and other load carrying devices are considered part of the load. The weight of standard hoisting ropes for the rating at a given radius has been calculated as part of the boom point load and need not be considered in determining net allowable loads. See Appendix A.

Ratings shown on this chart make no allowance for such factors as out of plumb loads, wind, poor soil conditions, improper inflation of rubber tires and dynamic effects due to excessive operating speeds. The user (operator) must exercise judgement to make allowance for these conditions. See page 3499 of Operator's Manual for detailed information.

No account is taken of the wind force on the load. This effect, which can be substantial for loads with large surface areas, must be considered by the user. In any wind it is strongly recommended that taglines be used to control the load.

The weight of all suspended blocks, slings, or other load carrying devices including those at the main fall, are considered part of the jib load. The weight of standard hoisting ropes for the rating at a given radius has been calculated as part of the jib point dead load and need not be considered in determining net allowable loads. See Appendix A.

BOOM HOIST LINE – 14 parts of 5/8 inch diameter EIPS wire rope with a minimum breaking strength of 41,200 pounds.

PENDANT SUSPENSION LINE – 2 parts of 1-1/4 inch diameter MONOLAY wire rope with a minimum breaking strength of 172,800 pounds.

WHIP LINE – 7/8 inch diameter IPS wire rope with a minimum breaking strength of 69,200 pounds.

JIB FRONTSTAY & BACKSTAY PENDANTS – 7/8 inch diameter IPS wire rope with a minimum breaking strength of 69,200 pounds.

ERECTION

Erection is with the A-Frame fully raised. Erection „OVER-THE-END“ is with the boom over the idler end. Erection „OVER-THE-SIDE“ is with the boom 90° to the sideframes and with the side frames extended. Blocks, slings and other load carrying devices must be on the ground during erection.

MAXIMUM BOOM & JIB SELF-ERECTION DATA - 46HI BOOM		
JIB	OVER-THE-END & OVER-THE-SIDE	
	BOOM LENGTH (FEET)	JIB LENGTH (FEET)
#9	160	50

46HI BOOM COMPOSITION CHART						
BOOM LENGTH (FEET)	BOOM SECTIONS					
	20' 46HI INNER	5' 46HR CENTER	10' 46HR CENTER	20' 46HR CENTER	40' 46HR CENTER	20' 46HR or 46HI OUTER
40	1	0	0	0	0	1
45	1	1	0	0	0	1
50	1	0	1	0	0	1
55	1	1	1	0	0	1
60	1	0	0	1	0	1
65	1	1	0	1	0	1
70	1	0	1	1	0	1
75	1	1	1	1	0	1
80	1	0	0	0	1	1
85	1	1	0	0	1	1
90	1	0	1	0	1	1
95	1	1	1	0	1	1
100	1	0	0	1	1	1
105	1	1	0	1	1	1
110	1	0	1	1	1	1
115	1	1	1	1	1	1
120	1	0	0	0	2	1
125	1	1	0	0	2	1
130	1	0	1	0	2	1
135	1	1	1	0	2	1
140	1	0	0	1	2	1
145	1	1	0	1	2	1
150	1	0	1	1	2	1
155	1	1	1	1	2	1
160	1	0	0	0	3	1

LOAD HOISTING INFORMATION - 7/8" diameter IPS wire rope			
MAXIMUM LIFTING CAPACITY - LBS.	MINIMUM PARTS OF LINE	MAXIMUM HOISTING DISTANCE - FEET	
		MAIN - (RIGHT)	AUX. - (LEFT)
18,250	1	588	588

#9 JIB COMPOSITION CHART							
JIB LENGTH (FEET)	10' INNER	10' CENTER	10' OUTER	EFF. JIB WEIGHT (POUNDS)	JIB OFFSET "A" IN FEET		
					5°	15°	25°
20	1	0	1	1,550	3.75	6.00	8.50
30	1	1	1	2,100	3.50	7.83	11.58
40	1	2	1	2,800	5.08	9.67	14.50
50	1	3	1	3,600	5.33	11.58	17.75

Note: The #9 jib mounted on a 46HI outer requires the use of a 46HI #9 jib adaptor. Refer to the HC 80 Operator's Manual for additional information.

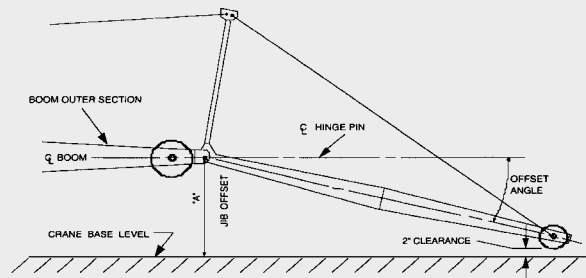

TECHNICAL DESCRIPTION**HYDRAULIC CRAWLER CRANE****Maximum lifting capacity**

80 tons (73 mt).

Boom systems

47 HI Boom with Offset Tip

- 200 ft (61 m) maximum boom length.
- 230 ft (70 m) maximum boom and jib combination length.
- 47 HI Tubular chord boom, pin connected.
- 20 ft inner and 20 ft outer and 10 ft / 20 ft / 30 ft available inserts provide boom compositions in 10 ft increments from 40 ft to 200 ft.

46 HR Angle Boom with 4 Sheave Tip

- 160 ft maximum boom length.
- 200 ft (61 m) maximum boom and jib combination length.
- 46 HR Angle Boom, pin connected.
- 20 ft inner and 20 ft outer and 10 ft / 20 ft / 30 ft available inserts provide boom compositions in 10 ft increments from 40 ft to 160 ft.

Robust engine

- Cummins Model QSB 5.9 Turbocharged After Cooled diesel engine, 4 cycle, 6 cylinders, 359 cubic inch displacement, 5.9 liters, 185 BHP @2200 rpm, 60 gallons fuel tank capacity.

Environmental operator's cab

- Designed to provide excellent viewing range and quiet, comfortable operation.
- 37 inch (0.91 m) wide cab has wide curve windows on both top and bottom.
- Easy-to-operate modular and ergonomically designed controls reduce operator fatigue and increase productivity.
- Load Moment Indicator with interactive screen features as shockless stop system. Operator can select from three display modes: loaded condition diagram, rated lifting curve or rated lifting load table.
- Adjustable operator's seat, radio, air conditioner, overhead window, sun visor, fan, overhead and front wipers and drum rotation indicators are standard.

Heavy duty carbody and crawlers

- Fabricated steel carbody is deep box constructed with square axles for the crawler side frames. Precision machined top supports anti-friction swing circle and multiple pass hydraulic swivel joint.
- Crawlers have high alloy steel tumbler yokes and rigid fabricated structures with sealed rollers.
- 36" (914 mm) crawler shoes.
- Travel mechanism is set within shoe width.
- Side frames extended or retracted by cylinders inside the carbody.
- Two travel speed settings – 0.8 / 1.24 mph (1.3 / 2.0 km/h).
- 40 % (22°) gradeability.

Powerful, high-speed hoist system

- Identical inline, independent main and auxiliary load hoisting drums are grooved for 7/8 in. (22.4 mm) diameter rope. Line speed is 530 fpm (162 m/min.), line pull is 32,400 lb (14 697 kg).
- Each drum, including optional third, has power up/down and freefall. Load hoists are further controllable in stepless mode.
- Ample work space in front of the drums allows easy access for cable installation and maintenance.
- Internal expanding band clutch.
- 3.3 rpm swing speed.

High capacity, dependable hydraulic system

- Open circuit system has 2 variable displacement piston pumps with system capacity of 116 gpm (440 lpm).
- Hydraulic reservoir with 79 gallons (300 l) capacity and 10 micron filtration.
- Component working range is between -4 and 203° F (-20 and 95° C).
- Flip up doors provide easy access to engine and hydraulic components for service.

Three piece removable counterweight

- Three piece pin connected counterweight can be assembled or disassembled easily within minutes.
- Hydraulic counterweight removal system is standard and utilizes the „A“ frame and crane auxiliary drum to make the HC 80 one of the most transportable cranes in its class.
- Moves on three trucks with full boom and #9HL jib. Carbody sideframes and boom weigh in at under 88,000 lb (39 917 kg). At 11 ft 9.75 in. (3.6 m) wide and 10 ft 2 in. (3.09 m) high, the HC 80 at working weight will transport on a standard lowboy trailer.

Options include

- Third drum
- Automotive type lights
- Hydraulic power take off
- Jib and jib inserts
- Luffing jib attachment
- 46HI angle boom
- Single sheave extension

TRANSPORT EXAMPLE FOR HC 80

170' 47HI BOOM AND 60' #9HL JIB

Loads based on 48 ft flatbed trailer. Loading information is an example only, specific loads will vary depending on crane options. Weights shown do **NOT** include blocking or tie-down material.

LOAD NO. 1

3 x 47 H 30' Boom Center Sections @ 2,045 # each	6,135 lbs
Inside Counterweight	16,000 lbs
#9HL 20' Jib Center	385 lbs
Center Counterweight	21,000 lbs
1 x 47 H 10' Boom Center Sections	700 lbs
TOTAL LOAD	44,220 lbs

LOAD NO. 2

Outside Counterweight	21,000 lbs
47HI Boom Outer	2,225 lbs
47 H 30' Boom Center	2,045 lbs
#9HL Jib Inner	890 lbs
#9HL Jib Outer	665 lbs
Crate, Misc. Parts, Block & Ball	3,500 lbs
TOTAL LOAD	30,325 lbs

LOAD NO. 3

Basic Upper, including:

- a) Carbody
- b) Sideframes
- c) Boom Inner

TOTAL LOAD (BASIC CRANE, etc.)	88,000 lbs
---	-------------------

KEY

-  Counterweight
- CB Central ballast

The information contained in this brochure merely consists of general descriptions and a broad compilation of performance features which might not apply precisely as described under specific application conditions or which may change as a result of further product development. The desired performance features only become binding once expressly agreed in the final contract.

Note: Data published herein is intended as a guide only and shall not be construed to warrant applicability for lifting purposes. Crane operation is subject to the computer charts and operation manual both supplied with the crane.

Subject to change without notice.

03 / 06

Terex Cranes Wilmington Operations

Mobile hydraulic and lattice-boom cranes
202 Raleigh St. · Wilmington, NC 28412 USA
Phone +1 910 395 8500 · Fax +1 910 395 8538
Email: american@american-crane.com