

Specifications

MODEL **GTH-3514R**

MEASUREMENTS	Metric	Imperial
Lifting height (maximum)	13.55 m	44 ft 5 in
Lifting capacity (maximum)	3,500 kg	7,715 lbs
Lift capacity at maximum height	2,500 kg	5,511 lbs
Lift capacity at maximum reach	700 kg	1,543 lbs
Forward reach (maximum)	11.29 m	37 ft
Reach at maximum height	2.9 m	9 ft
A Height	2.93 m	9 ft 6 in
B Height at steering wheel	2.07 m	6 ft 9 in
C Width	2.40 m	7 ft 5 in
D Inside cab width	91 cm	3 ft
E Track	1.95 m	6 ft 5 in
F Wheelbase	3.03 m	9 ft 11 in
G Length at stabilisers	4.86 m	15 ft 11 in
H Length at fork-holder plate	5.79 m	19 ft
I Ground clearance	37 cm	1 ft 2 in
L Overall width, stabilisers extended	3.66 m	12 ft
M1 Obstruction angle	23°	23°
M2 Departure angle	23°	23°

PRODUCTIVITY

Lifting/lowering speed	15 sec./10 sec.	15 sec./10 sec.
Extension/retraction speed	17 sec./27 sec.	17 sec./27 sec.
Inside/outside turning radius	2.34 m/4 m	7 ft 8 in/13 ft 1 in
Break out force	7,400 kg	16,312 lbs
(with 500L shovel SAE J 732/80)		
Towing capacity at dynamometer	7,000 kg	15,431 lbs
Travel speed	30 km/h	18.6 mph
Fork-holder plate rotation	145°	145°
Floating forks	L 1200 mm Section 130 x 50 mm	L 3 ft 11 in Section 5 in x 2 in
Tyres (DIN 70361)	18-19.5" PR16 8 holes wheel disc	

POWER

Engine	Perkins Turbo Diesel 74,4 kW (101 HP)	
Tank capacities		
Fuel	125 L	27 gal
Engine oil	11.5 L	2 gal
Hydraulic oil	200 L	44 gal
Hydraulic output/pressure	130 L/min-250 bars	29 gal/min-3,626 psi

WEIGHT

Weight*	11,700 kg	25,791 lbs
---------	-----------	------------

STANDARDS COMPLIANCE

Operating cab conforms to ISO3471 (ROPS) and ISO3449 (FOPS)
Low emission engine conforms to UE 97/68 directives.

* Weight will vary depending on options and/or country standards

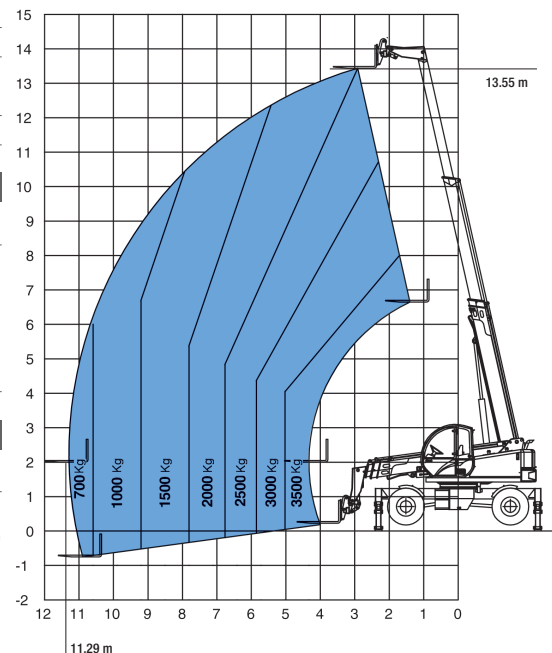
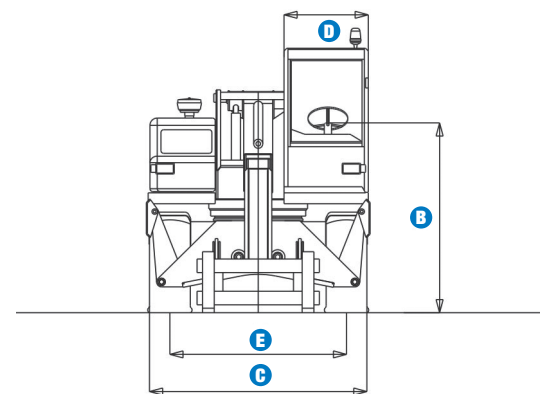
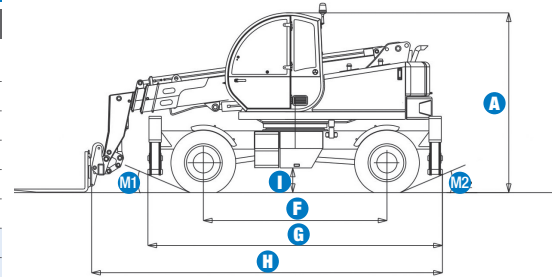

Lift capacity chart (with stabilisers)

EN1459, Annex B

Features

STANDARD FEATURES

MEASUREMENTS

- 3,500 kg (7,715 lbs) maximum lift capacity
- 13.55 m (44 ft 5 in) maximum lift height
- 11.29 m (37 ft) maximum forward reach

PRODUCTIVITY

- Four-wheel drive
- 3 steering modes:
 - front wheel steer
 - crab steer
 - coordinated steer
- Power assisted steering
- Two-speed mechanical gearbox
- Front and rear stabilisers
- Hydrostatic transmission
- 4x1 multifunction electro-proportional joystick
- Chassis levelling
- Limited slip differential on front axle
- Quick coupling of tools
- Fork-holder plate and floating forks
- Adjustable suspended seat
- Large diameter steering wheel
- Front windscreen wipers
- Front & rear lights
- Oil immersed, multi-disc, self-adjusting brakes on both axles
- Lockable fuel tank
- Longitudinal stability control system with load monitor
- Visible display with coloured LEDs
- Audible alarm
- Automatic lock-out of boom extension and lowering
- Lockout of stabilisers and chassis levelling with boom raised
- Control enable switch

POWER

- Perkins Turbo Diesel 74,4 kW (101 HP)

TYRES

- 18-19.5" PR16 8 holes wheel disc

OPTIONS & ACCESSORIES

PRODUCTIVITY

- Centering-holder boom pre-arrangement
- Pre-arrangement for man-platform
- Emergency electric pump
- Pre-arrangement for hydraulic jib/winch
- Pre-arrangement for Robot 8000
- Continuous rotation
- Air conditioning
- Pre-arrangement for mixing bucket
- Second hydraulic line on boom
- Windshield protection grid
- Adjustable spotlight
- Wiper on cab roof
- Water muffler
- Complete radio remote with only one joystick
- High proportional valve-block
- Double left joystick for rotation

ATTACHMENT OPTIONS

- Loading shovel 500/800 L
- Concrete bucket 500/800 L manual/hydraulic discharge
- Concrete mixing bucket 500 L with remote control
- Hydraulic jack 10 ton + box wrench 24 mm
- Brick-holder basket
- Fork side-shift +/- 100 mm
- Fixed hook on plate
- 4 m jib, 900 kg capacity
- 4 m jib with 900 kg capacity hydraulic winch
- Hydraulic winch 3000 kg
- Rotating and extendible man-platform up to 5.5 m
- Centering-holder boom
- Man-platform robot 8000

TYRES

- Foam-filled tyres
- Spare wheel 18-19.5" PR16

European Offices

UK

The Maltings
Wharf Road
Grantham NG31 6BH
UK
Tel: +44 (0)1476 584333
Fax: +44 (0)1476 584334

France

10, ZA de la Croix St. Mathieu
28320 Gallardon
France
Tel: +33 (0)2 37 26 09 99
Fax: +33 (0)2 37 26 09 98

Germany

Finienweg 3
28832 Achim/Bremen
Germany
Tel: +49 (0)4202 8852-0
Fax: +49 (0)4202 8852-25

Spain

Gaià 31, Pol. Ind. Plà d'en Coll
08110 Montcada i Reixac
Barcelona
Spain
Tel: +34 93 572 50 90
Fax: +34 93 572 50 91

Scandinavia

Tagenevägen 72
425 37 Hisings Kärra
Sweden
Tel: +46 31 57 51 00
Fax: +46 31 57 90 20

Genie United States

18340 NE 76th Street
P.O. Box 97030
Redmond, Washington 98073-9730
USA
Tel: +1 425 881-1800
Fax: +1 425 883-3475

WEB: www.genieindustries.com
Email: infoeurope@genieind.com

Distributed By: