

Specifications

MODEL		GTH-2506	
MEASUREMENTS		Metric	Imperial
Lifting height (max)		5.75 m	18 ft 10 in
Lifting capacity (max)		2,500 kg	5,511 lbs
Lift capacity at maximum height		1,250 kg	2,755 lbs
Lift capacity at maximum reach		800 kg	1,763 lbs
Forward reach (max)		3.34 m	11 ft
Reach at maximum height		45 cm	1 ft 6 in
A Height		1.92 m	6 ft 4 in
B Height at steering wheel		1.23 m	4 ft
C Width		1.8 m	5 ft 11 in
D Inside cab width		86 cm	2 ft 10 in
E Track		1.5 m	4 ft 11 in
F Wheelbase		2.28 m	7 ft 6 in
G Length at front wheels		3.31 m	10 ft 10 in
H Length at fork-holder plate		3.72 m	12 ft 2 in
I Ground clearance		36 cm	1 ft 2 in
M1 Obstruction angle		90°	90°
M2 Departure angle		70°	70°

PRODUCTIVITY			
Inside/outside turning radius		1.68 m/3.34 m	6 ft 6 in/ 11 ft
Lifting/lowering speed		7 sec/4 sec	7 sec/4 sec
Extension/retraction speed		7 sec/4 sec	7 sec/4 sec
Break-out force (with 500 L shovel SAE J 732/80)		3,700 kg	8,156.3 lbs
Towing capacity at dynamometer		4,650 kg	10,251 lbs
Travel speed (max)		24 km/h	15 mph
Fork-holder plate rotation		135°	135°
Floating forks		L 1,200 mm Section 100x40mm	L 3 ft 11 in Section 4.5 in x 2 in
Tyres (DIN 70361)		12-16.5 PR10 8-holes wheel disc	

POWER			
Engine		Deutz F4M 2011 Diesel 63 hp (47kW)	
Tank capacities			
Fuel		60 L	13 gal
Engine oil		8 L	1.75 gal
Hydraulic oil		70 L	15 gal
Hydraulic output/pressure		67 L/min-260 bars	14.5 gal/min-3,771 psi

WEIGHT			
Weight*		4450 kg	9,810 lbs

STANDARDS COMPLIANCE Operating cab conforms to ISO3471 (ROPS) and ISO3449 (FOPS)
Low emission engine conforms to UE 97/68 directives.

* Weight will vary depending on options and/or country standards

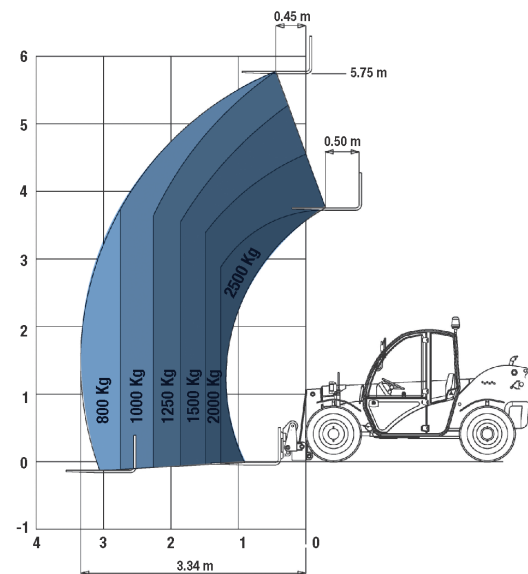
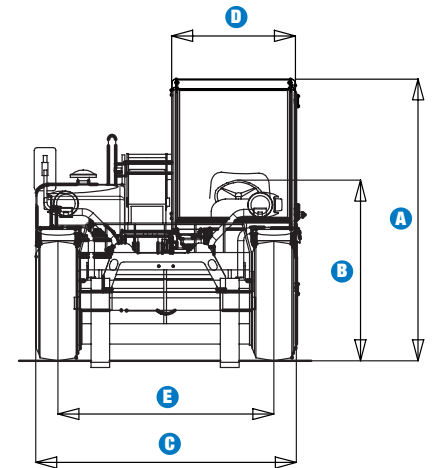
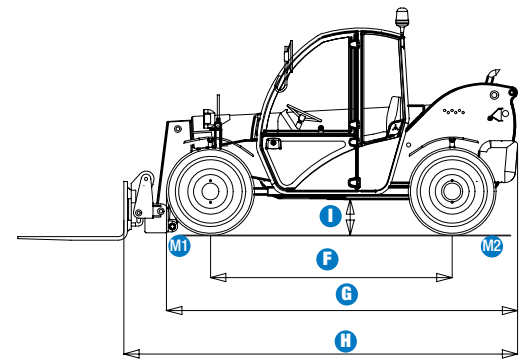

Lift capacity chart
With floating forks
(L 1200 mm-section 100x40 mm)

EN1459, Annex B

Features

EASILY CONFIGURED TO MEET YOUR NEEDS

STANDARD FEATURES

MEASUREMENTS

- 2,500 kg (5,511 lbs) maximum lift capacity
- 5.75 m (18 ft 10 in) maximum lift height
- 3.34 m (11 ft) maximum forward reach

PRODUCTIVITY

- Four-wheel drive
- 3 steering modes:
 - front wheel steer
 - crab steer
 - coordinated steer
- Power assisted steering
- Quick coupling of tools from cab
- Two-speed hydrostatic motor coupled to a two-speed mechanical gearbox
- Multifunction proportional joystick hydraulically piloted
- Self locking on front axle differential
- Floating forks
- Attachment holder plate with mechanical coupling
- Adjustable suspended seat
- Large diameter steering wheel
- Front windscreen wipers
- Front & rear lights
- Side-mounted engine for easy access to components
- Oil immersed multi-disc brakes on front axle
- Lockable fuel tank
- Longitudinal stability control system with load monitor including specific load programs according to the individual attachments used
- Visible display with coloured LEDs
- Audible alarm
- Automatic lock-out of boom extension and lowering
- Control enable switch

POWER

- Deutz Diesel 63 hp (47 kW)

OPTIONS & ACCESSORIES

PRODUCTIVITY

- Air conditioning
- Windshield protection grid
- Adjustable spotlight
- Additional armrest
- Mixing bucket pre-arrangement

ATTACHMENT OPTIONS

- Forks side-shift (+/- 100 mm)
- Fixed hook on plate
- Brick-holder basket
- 500 Lt concrete bucket, manual discharge
- 500 Lt concrete bucket, hydraulic discharge
- 2 m jib, 400 kg capacity
- 500 Lt loading shovel
- 800 Lt light material loading shovel
- 250 Lt concrete mixing bucket
- Drilling accessory 250 mm

TYRES

- Foam-filled tyres

European Offices

UK

The Maltings
Wharf Road
Grantham NG31 6BH
UK
Tel: +44 (0)1476 584333
Fax: +44 (0)1476 584334

France

10, ZA de la Croix St. Mathieu
28320 Gallardon
France
Tel: +33 (0)2 37 26 09 99
Fax: +33 (0)2 37 26 09 98

Germany

Finienweg 3
28832 Achim/Bremen
Germany
Tel: +49 (0)4202 8852-0
Fax: +49 (0)4202 8852-25

Spain

Gaià 31, Pol. Ind. Plà d'en Coll
08110 Montcada i Reixac
Barcelona
Spain
Tel: +34 93 572 50 90
Fax: +34 93 572 50 91

Scandinavia

Tagenevägen 72
425 37 Hisings Kärra
Sweden
Tel: +46 31 57 51 00
Fax: +46 31 57 90 20

Genie United States

18340 NE 76th Street
P.O. Box 97030
Redmond, Washington 98073-9730
USA
Tel: +1 425 881-1800
Fax: +1 425 883-3475

WEB: www.genieindustries.com
Email: infoeurope@genieind.com

Distributed By: