

Features

EASILY CONFIGURED TO MEET YOUR NEEDS

PLATFORM OPTIONS

- Sliding mid-rail standard platform
- Gated standard platform
- Gated ultra narrow platform
- Gated narrow platform
- Standard fibreglass platform
- Narrow fibreglass platform

POWER OPTIONS

- AC power 110 V / 50-60 Hz
- AC power 220 V / 50-60 Hz
- DC power 110 V / 60 Hz automatic "smart" charging system
- DC power 110/230 V / 50-60 Hz worldwide model
- Air motor power 1.5 hp (1.1 kW) (AWP™-30 only)

BASE OPTIONS

- Standard base
- Narrow base (AWP™-20, -25, 30 only)
- Rough terrain (RT) base (AWP™-20, -25, 30 only)

OPTIONS & ACCESSORIES

PRODUCTIVITY

- Tilt-back frame (option on AWP™-20, -25, -30 only)
- Platform locating laser light
- Tool tray
- Fluorescent tube caddy
- Operational warning light and descent alarm package
- Gated standard platform
- Gated ultra narrow platform
- Gated narrow platform
- Standard fibreglass platform
- Narrow fibreglass platform
- Narrow base conversion kit (AWP™-20, -25, -30 RT only)
- RT conversion kit (AWP™-20, -25, -30 Narrow only)

POWER

- Air motor power 1.5 hp (1.1 kW) (AWP™-30 only)



Standard Base

STANDARD FEATURES

MEASUREMENTS

AWP™-20S

- 8.12 m (26 ft 1 in) working height
- 6.12 m (20 ft 1 in) platform height
- 74 cm (2 ft 5 in) standard base width
- 56 cm (1 ft 10 in) narrow base width
- 76 cm (2 ft 6 in) RT base width
- Up to 159 kg (350 lb) lift capacity

AWP™-25S

- 9.54 m (30 ft 9 in) working height
- 7.54 m (24 ft 9 in) platform height
- 74 cm (2 ft 5 in) standard base width
- 56 cm (1 ft 10 in) narrow base width
- 76 cm (2 ft 6 in) RT base width
- Up to 159 kg (350 lb) lift capacity

AWP™-30S

- 11.02 m (35 ft 6 in) working height
- 9.02 m (29 ft 6 in) platform height
- 74 cm (2 ft 5 in) standard base width
- 56 cm (1 ft 10 in) narrow base width
- 76 cm (2 ft 6 in) RT base width
- Up to 159 kg (350 lb) lift capacity

AWP™-36S

- 13.16 m (42 ft 6 in) working height
- 11.16 m (36 ft 6 in) platform height
- 74 cm (2 ft 5 in) standard base width
- Up to 159 kg (350 lb) lift capacity

AWP™-40S

- 14.26 m (46 ft 3 in) working height
- 12.26 m (40 ft 3 in) platform height
- 74 cm (2 ft 5 in) standard base width
- Up to 136 kg (300 lb) lift capacity

PRODUCTIVITY

- Sliding mid-rail platform
- AC power to platform
- Auxiliary platform lowering
- Dual activated up/down switch
- Ground fault interrupt power receptacle
- Most rigid mast in the industry
- Small outrigger footprints
- Outrigger storage pockets
- Rocker base system for manoeuvrability
- Tilt base frame (standard on AWP™-36, -40)
- Easily rolls through standard doorways
- Easy loading in pickup trucks
- Overhead crane attachment points
- Wide forklift pockets
- Tie down attachment points
- LED lights confirm proper set-up

POWER

- AC power 110 V / 50-60 Hz
- AC power 220 V / 50-60 Hz
- DC power 110 V / 60 Hz with automatic "smart" charging system
- DC power 110/230 V / 50-60 Hz Worldwide model with a voltage adjustable, hertz compensating, automatic "smart" charging system

Specifications

MODELS	AWP™-20S		AWP™-25S		AWP™-30S	
MEASUREMENTS	Metric	US	Metric	US	Metric	US
Working height*	8.12 m	26 ft 1 in	9.54 m	30 ft 9 in	11.02 m	35 ft 6 in
Platform height	6.12 m	20 ft 1 in	7.54 m	24 ft 9 in	9.02 m	29 ft 6 in
A Height - stowed (Standard, Narrow)	1.98 m	6 ft 6 in	1.98 m	6 ft 6 in	1.98 m	6 ft 6 in
stowed (RT)	2.01 m	6 ft 7 in	2.01 m	6 ft 7 in	2.01 m	6 ft 7 in
B tilted back** (Standard)	1.78 m	5 ft 10 in	1.84 m	6 ft .3 in	1.89 m	6 ft 2.5 in
C Length - stowed (Standard)	1.24 m	4 ft 1 in	1.31 m	4 ft 3.5 in	1.35 m	4 ft 5 in
stowed (Narrow)	1.27 m	4 ft 2 in	1.32 m	4 ft 4 in	1.40 m	4 ft 7 in
stowed (RT)	1.47 m	4 ft 10 in	1.47 m	4 ft 10 in	1.47 m	4 ft 10 in
D Length - tilted back**	2.10 m	6 ft 11 in	2.10 m	6 ft 11 in	2.10 m	6 ft 11 in
E Width (Standard)	74 cm	2 ft 5 in	74 cm	2 ft 5 in	74 cm	2 ft 5 in
Width (Narrow)	56 cm	1 ft 10 in	56 cm	1 ft 10 in	56 cm	1 ft 10 in
Width (RT)	76 cm	2 ft 6 in	76 cm	2 ft 6 in	76 cm	2 ft 6 in

PRODUCTIVITY						
Lift capacity - CE	159 kg	350 lbs	159 kg	350 lbs	159 kg	350 lbs
CE Indoor:						
F G Outrigger footprint (l/w) (Standard)	1.55 m/1.35 m	5 ft 1 in/4 ft 5 in	1.75 m/1.55 m	5 ft 9 in/5 ft 1 in	1.93 m/1.73 m	6 ft 4 in/5 ft 8 in
Outrigger footprint (l/w) (Narrow/RT)	1.80 m/1.47 m	5 ft 11 in/4 ft 10 in	1.80 m/1.47 m	5 ft 11 in/4 ft 10 in	2.11 m/1.88 m	6 ft 11 in/6 ft 2 in
H Corner access*** (Standard)	38 cm	1 ft 3 in	48 cm	1 ft 7 in	56 cm	1 ft 10 in
Corner access*** (Narrow/RT)	53 cm	1 ft 9 in	51 cm	1 ft 8 in	70 cm	2 ft 3.5 in
I J Wall access front/side (Standard)	15 cm/33 cm	6 in/1 ft 1 in	18 cm/43 cm	7 in/1 ft 5 in	20 cm/53 cm	8 in/1 ft 9 in
Wall access front/side (Narrow/RT)	30 cm/43 cm	1 ft/1 ft 5 in	25 cm/43 cm	10 in/1 ft 5 in	23 cm/51 cm	9 in/1 ft 8 in
CE Outdoor:						
F G Outrigger footprint (l/w) (Standard)	2.46 m/2.26 m	8 ft 1 in/7 ft 5 in	2.97 m/2.79 m	9 ft 9 in/9 ft 2 in	2.97 m/2.79 m	9 ft 9 in/9 ft 2 in
Outrigger footprint (l/w) (Narrow/RT)	2.84 m/2.84 m	9 ft 4 in/9 ft 4 in	2.84 m/2.84 m	9 ft 4 in/9 ft 4 in	3.30 m/3.45 m	10 ft 10 in/11 ft 4 in
H Corner access*** (Standard)	48 cm	1 ft 7 in	76 cm	2 ft 6 in	69 cm	2 ft 3 in
Corner access*** (Narrow/RT)	1.37 m	4 ft 6 in	1.32 m	4 ft 4 in	1.55 m	5 ft 1 in
I J Wall access front/side (Standard)	48 cm /81 cm	1 ft 7 in/2 ft 8 in	74 cm/1.07 m	2 ft 5 in/3 ft 6 in	69 cm/1.07 m	2 ft 3 in/3 ft 6 in
Wall access front/side (Narrow/RT)	81 cm/1.12 m	2 ft 8 in/3 ft 8 in	74 cm/1.12 m	2 ft 5 in/3 ft 8 in	89 cm/1.40 m	2 ft 11 in/4 ft 7 in
Platform Dimensions: (l/w/h)						
Standard	69 cm/66 cm/1.14 m	27/26/44.75 in	69 cm/66 cm/1.14 m	27/26/44.75 in	69 cm/66 cm/1.14 m	27/26/44.75 in
Gated	69 cm/66 cm/1.14 m	27/26/44.75 in	69 cm/66 cm/1.14 m	27/26/44.75 in	69 cm/66 cm/1.14 m	27/26/44.75 in
Gated ultra narrow	56 cm/46 cm/1.14 m	22/18/44.75 in	56 cm/46 cm/1.14 m	22/18/44.75 in	56 cm/46 cm/1.14 m	22/18/44.75 in
Gated narrow	66 cm/51 cm/1.14 m	26/20/44.75 in	66 cm/51 cm/1.14 m	26/20/44.75 in	66 cm/51 cm/1.14 m	26/20/44.75 in
Standard fibreglass						
Standard	74 cm/67 cm/1.10 m	29/26.5/43.5 in	74 cm/67 cm/1.10 m	29/26.5/43.5 in	74 cm/67 cm/1.10 m	29/26.5/43.5 in
Narrow fibreglass	66 cm/56 cm/1.10 m	26/22/43.5 in	66 cm/56 cm/1.10 m	26/22/43.5 in	66 cm/56 cm/1.10 m	26/22/43.5 in

POWER			
Power source - AC or DC models	12V / 110V /50-60 Hz or 220V/50-60 Hz	12V / 110V /50-60 Hz or 220V/50-60 Hz	12V / 110V /50-60 Hz or 220V/50-60 Hz

WEIGHT						
AC models (Standard)	307 kg	677 lbs	330 kg	727 lbs	352 kg	777 lbs
AC models (Narrow)	297 kg	655 lbs	313 kg	690 lbs	328 kg	724 lbs
AC models (RT)	299 kg	660 lbs	315 kg	694 lbs	331 kg	729 lbs
DC models (Standard)	348 kg	767 lbs	371 kg	817 lbs	393 kg	867 lbs
DC models (Narrow)	338 kg	745 lbs	354 kg	780 lbs	369 kg	814 lbs
DC models (RT)	340 kg	750 lbs	356 kg	784 lbs	371 kg	819 lbs

STANDARDS COMPLIANCE	
CE EN280	

Specifications

MODELS	AWP™-36S		AWP™-40S	
	Metric	US	Metric	US
MEASUREMENTS				
Working height*	13.16 m	42 ft 6 in	14.26 m	46 ft 3 in
Platform height	11.16 m	36 ft 6 in	12.26 m	40 ft 3 in
A Height - stowed (Standard, Narrow) stowed (RT)	2.78 m	9 ft 1.5 in	2.78 m	9 ft 1.5 in
B tilted back** (Standard)	1.92 m	6 ft 3.5 in	1.98 m	6 ft 6 in
C Length - stowed (Standard) stowed (Narrow) stowed (RT)	1.40 m	4 ft 7 in	1.42 m	4 ft 8 in
D Length - tilted back**	2.97 m	9 ft 9 in	2.97 m	9 ft 9 in
E Width (Standard) Width (Narrow) Width (RT)	74 cm	2 ft 5 in	74 cm	2 ft 5 in

PRODUCTIVITY				
Lift capacity - CE	159 kg	350 lbs	136 kg	300 lbs
CE Indoor:				
F G Outrigger footprint (l/w) (Standard) Outrigger footprint (l/w) (Narrow/RT)	2.10 m/1.90 m	6 ft 11 in/6 ft 3 in	2.26 m/2.06 m	7 ft 5 in /6 ft 9 in
H Corner access*** (Standard) Corner access*** (Narrow/RT)	74 cm	2 ft 5 in	79 cm	2 ft 7 in
I J Wall access front/side (Standard) Wall access front/side (Narrow/RT)	36 cm/64 cm	1 ft 2 in/2 ft 1 in	38 cm/71 cm	1 ft 3 in/2 ft 4 in
CE Outdoor:				
F G Outrigger footprint (l/w) (Standard) Outrigger footprint (l/w) (Narrow/RT)	3.53 m/3.33 m	11 ft 7 in/10 ft 11 in	3.89 m /3.68 m	12 ft 9 in/12 ft 1 in
H Corner access*** (Standard) Corner access*** (Narrow/RT)	1.02 m	3 ft 4 in	1.12 m	3 ft 8 in
I J Wall access front/side (Standard) Wall access front/side (Narrow/RT)	1.02 m/1.32 m	3 ft 4 in/4 ft 4 in	1.12 m/1.52 m	3 ft 8 in/5 ft
Platform Dimensions: (l/w/h)				
Standard	69 cm/66 cm/1.14 m	27/26/44.75 in	69 cm/66 cm/1.14 m	27/26/44.75 in
Gated	69 cm/66 cm/1.14 m	27/26/44.75 in	69 cm/66 cm/1.14 m	27/26/44.75 in
Gated ultra narrow	56 cm/46 cm/1.14 m	22/18/44.75 in	56 cm/46 cm/1.14 m	22/18/44.75 in
Gated narrow	66 cm/51 cm/1.14 m	26/20/44.75 in	66 cm/51 cm/1.14 m	26/20/44.75 in
Standard fibreglass	74 cm/67 cm/1.10 m	29/26.5/43.5 in	74 cm/67 cm/1.10 m	29/26.5/43.5 in
Narrow fibreglass	66 cm/56 cm/1.10 m	26/22/43.5 in	66 cm/56 cm/1.10 m	26/22/43.5 in

POWER		
Power source - AC or DC models	12V / 110V/50-60 Hz or 220V/50-60 Hz	12V / 110V/50-60 Hz or 220V/50-60 Hz

WEIGHT				
AC models (Standard)	461 kg	1,017 lbs	472 kg	1,040 lbs
AC models (Narrow)	_____	_____	_____	_____
AC models (RT)	_____	_____	_____	_____
DC models (Standard)	502 kg	1,107 lbs	513 kg	1,130 lbs
DC models (Narrow)	_____	_____	_____	_____
DC models (RT)	_____	_____	_____	_____

STANDARDS COMPLIANCE	CE EN280
----------------------	----------

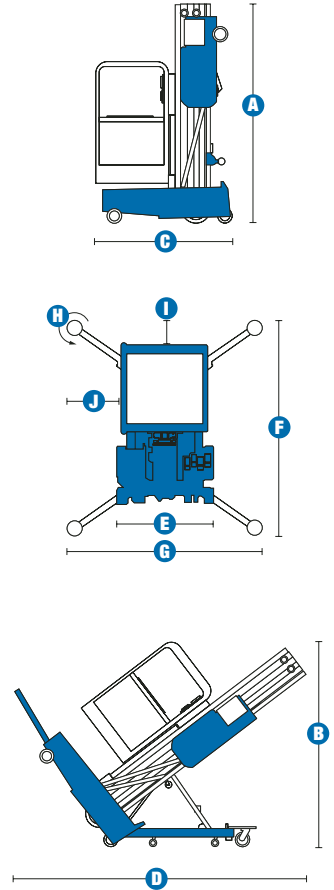

* The metric equivalent of working height adds 2 m to platform height. U.S. adds 6 ft to platform height.
 ** Tilt back height with standard platform. For tilt back height with other platforms, please contact your sales representative.
 *** Corner of platform top rail to corner of wall with ability to rotate leveling jack handle.



Standard Base



Narrow Base



Rough Terrain Base



Fiberglass Standard Platform



Fiberglass Narrow Platform



Gated Ultra Narrow Platform



Standard Platform



Gated Standard Platform

European Offices

UK

The Maltings
Wharf Road
Grantham NG31 6BH
UK
Tel: +44 (0)1476 584333
Fax: +44 (0)1476 584334

France

10, ZA de la Croix St. Mathieu
28320 Gallardon
France
Tel: +33 (0)2 37 26 09 99
Fax: +33 (0)2 37 26 09 98

Germany

Finienweg 3
28832 Achim/Bremen
Germany
Tel: +49 (0)4202 8852-0
Fax: +49 (0)4202 8852-20

Spain

Gaià 31, Pol. Ind. Plà d'en Coll
08110 Montcada i Reixac
Barcelona
Spain
Tel: +34 93 572 50 90
Fax: +34 93 572 50 91

Scandinavia

Tagenevägen 72
425 37 Hisings Kärra
Sweden
Tel: +46 31 57 51 00
Fax: +46 31 57 90 20

Genie United States

18340 NE 76th Street
P.O. Box 97030
Redmond, Washington 98073-9730
USA
Tel: +1 425 881-1800
Fax: +1 425 883-3475

WEB: www.genieindustries.com
Email: infoeurope@genieind.com